

NILU : OR 71/96
REFERENCE : O-96082
DATE : DECEMBER 1996
ISBN : 82-425-0835-6

BAQMAP

Air Quality Monitoring and Surveillance Programme, Botswana

Mission 1 Report, 4 - 22 November 1996

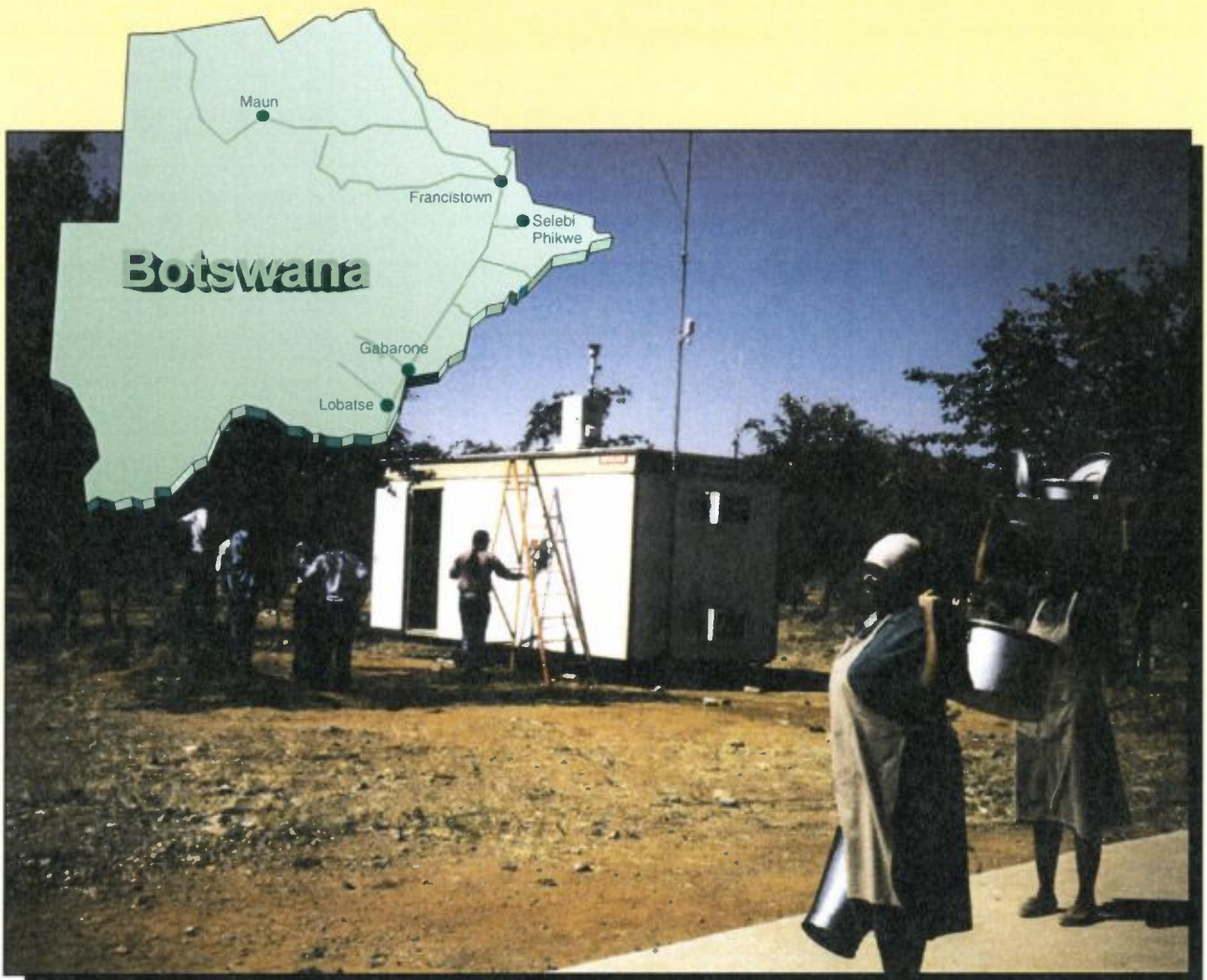

Norwegian Institute
of Air Research



Department
of Mines

NILU : OR 71/96
REFERENCE : O-96082
DATE : DECEMBER 1996
ISBN : 82-425-0835-6

BAQMAP
Air Quality Monitoring
and Surveillance Program
for Botswana

Mission 1 Report
4-22 November 1996

Tone Bekkestad, Rolf Dreiem,
Ove Hermansen and Svein Knudsen

Contents

	Page
Summary.....	5
1. Introduction.....	7
2. Seminar 4-8 November 1996, President Hotel, Gaborone	8
2.1 Introduction.....	8
2.2 Monday 4 November 1996	8
2.3 Tuesday 5 November 1996	10
2.4 Wednesday 6 November 1996	11
2.5 Thursday 7 November 1996.....	12
2.6 Friday 8 November 1996	13
3. Site visits to sampling stations in Botswana	14
3.1 Site visits.....	14
3.1.1 Selebi Phikwe	18
3.1.2 Gaborone	19
3.2 Air Quality data retrieval and storing	20
3.2.1 Emission inventory	20
3.2.2 Future work on emission inventories	21
3.2.3 Available air quality data from monitors.....	21
3.2.4 Missing data handling.....	21
3.2.5 Data storing	22
3.2.6 Statistical programs	22
3.3 Air quality measurements	23
4. Future air quality monitoring program. Preliminary Proposal.....	27
4.1 Strategy	27
4.2 Site selection	28
4.3 Preliminary proposed national monitoring program for Botswana. Presented to DoM (C.J. Matala) 22 November 1996	29
5. Field equipment.....	32
5.1 Type of equipment needed.....	32
5.2 Monitoring station facilities.....	32
6. Chemical laboratory	33
6.1 Present status.....	33
6.1.1 Gaborone	33
6.1.2 Selebi Phikwe	33
6.2 Type of equipment needed.....	34
6.3 QA/QC workshop	34
6.4 Planning of a new laboratory	34
7. Training assessment.....	35
8. References	37
Appendix A Seminar program	39

Appendix B Opening speech by the Hounourable Minister of Mineral Resources and Water Affairs	43
Appendix C List of participant and people we met.....	61
Appendix D Reports from seminar i national newspapers.....	67
Appendix E Meeting between DoM, NILU and NORAD 14 November 1996.....	71
Appendix F Site visit reports. Air quality sampling stations in Botswana.....	75
Appendix G Inventory lists for the laboratories for chemical analysis in Gaborone and Selebi Phikwe.....	173
Appendix H Laboratory measurement programme parameters	177
Appendix I Workshop QA & QC in the laboratory	181
Appendix J Air Quality Monitoring and Surveillance Program – Botswana – Planning of new laboratory	189
Appendix K Visit at the water laboratory, Department of Water Affairs 8 November 1996.....	201
Appendix L What, How, Who and When for the chemical laboratory	205
Appendix M Inventory list. Gaborone Calibration Laboratory	211
Appendix N Inventory list. Equipment at site.....	215
Appendix O Description of procedure for calibration of Monitor Lab Nitrogen Oxides Analyzer, Model 9841(A).....	219
Appendix P Selected air quality data from Gaborone	227
Appendix Q Selected air quality data from Serowe	237
Appendix R Selected air quality data Tonota	243
Appendix S Selected air quality and meteorological data from Mmadinare.....	247
Appendix T Example of forms from emission inventory	257
Appendix U Dust sampling at the Lobatse clay works.....	261
Appendix V Emission data from the BCL smelter in Selebi-Phikwe	270
Appendix W Pictures of the BCL smelter in Selebi-Phikwe.....	284
Appendix X Environmental Control Report September 1996 BCL Limited.....	288
Appendix Y Reports from the Meteorological Office in Gaborone	311
Appendix Z Annual Report 1993 Air Pollution Control Dept. of Mines.....	335
Appendix AA Main goal, main functions and objectives for the Air Pollution Control Division at DoM	363

Appendix BB Working plan for November 1996 to November 1997.....	367
Appendix CC Budget for November 1996 to November 1997.....	371

Summary

The project “Air Pollution Monitoring and Surveillance Program for Botswana” (BAQMAP) was initiated in November 1996 with a “kick-off” seminar in Gaborone, Botswana. All participating experts from Botswana and Norway participated at the “kick-off” seminar held at President Hotel in Gaborone. All monitoring sites (both DoM and BCL) have been visited by the Norwegian team, and are described in Appendix F. The design and decision of the new national monitoring program for Botswana will be performed in January/February 1997.

A status report of the present air quality monitoring program, the present status of the chemical laboratory, and a preliminary proposed new monitoring program is presented in Chapter 4 and Chapter 6.

The Appendices presents examples of air quality data from the monitoring stations presently operating, examples of meteorological data for Botswana, inventory lists both for the laboratory and the monitoring sites and new work plan and budget for 1997.

BAQMAP

Air Quality Monitoring and Surveillance Program for Botswana

Mission 1 Report
4-22 November 1996

1. Introduction

As part of the development of an Air Pollution Monitoring and Surveillance Program for Botswana (BAQMAP), the project was initiated with a "kick-off" seminar in Gaborone, the capital of Botswana, the first week of November 1996.

The project is funded partly by NORAD and partly by the Botswana Government. The project is a co-operation between Norwegian Institute for Air Research (NILU) in Norway and Department of Mines (DoM) in Botswana. NILU shall provide professional assistance in the fields of:

- Siting and establishment of an air pollution monitoring network.
- Laboratory techniques, methods and routines.
- Quality control and quality assurance procedures (QA/QC).
- Emission data bases.
- Statistical data analysis and reporting.
- Atmospheric dispersion model estimates for air quality planning and impact assessment analysis.

The main objectives of the first visit was to hold an introductory seminar on "Air Pollution Monitoring and its Applications", perform a screening analysis of the present monitoring program for Botswana, look at the laboratory facilities in Selebi-Phikwe and Gaborone, and to introduce the Botswana experts to the different types of air pollution model that are used at NILU.

The persons participating in this first visit to Gaborone were:

- Tone Bekkestad (Project leader)
- Svein Knudsen (Modelling expert)
- Rolf Dreiem (Field instrument expert)
- Ove Hermansen (Chemical laboratory expert)
- Bjarne Sivertsen (Responsible for "kick-off" seminar).

2. Seminar 4-8 November 1996, President Hotel, Gaborone

2.1 Introduction

The seminar was the first of its kind in the Air Quality Monitoring and Surveillance Program for Botswana. The “kick-off” seminar indicated the start-up of the three year co-operation between the Norwegian institute for air research (NILU) and Department of Mines (DoM) establishing an air quality monitoring and surveillance system for the country of Botswana. The funding of the project and the “birth” of the project is thanked to the Norwegian Agency for Development Co-operation (NORAD) which is financing the Norwegian contribution to the project. The seminar program is shown in Appendix A.

2.2 Monday 4 November 1996

Mr. R. C. Gabonowe (Chief governmental mining engineer, DoM) opened the seminar giving a brief summary of the preparations for the project and the participating institutions before handing the chair to the Honorable Minister of Mineral Resources and Water Affairs, Botswana. The Honorable Minister welcomed the Norwegian representatives and thanked Norway and NILU for participating with some of its best scientists in this mutual 3 year co-operation on air pollution monitoring, modelling and chemical analysis. A copy of the address is given in Appendix B.

The Honorable Minister of Mineral Resources and Water Affairs then continued summarizing some of the main goals of the project. He also expressed that they are more than aware of the possible additional air pollution problems that might arise as a result of further development of Botswana (and other developing countries). He therefore stressed the need for a national air pollution monitoring program to determine whether emitted pollutants in different areas are within the air quality guideline values.

Another issue he stressed was ‘How to achieve the human resources needed to be sustainable when the project terminates?’. One of the main aspects in order to achieve this goal is the on-the-job training of the DoM personnel.

A special thank was therefore directed towards Norway and NILU contributing with some of it’s best scientists for the purpose of the project. The Honorable Minister expressed that rumours tell that NILU is one of the best in the field of air pollution monitoring and modelling and that he very much appreciated that NILU would accomodate the transfer of knowledge in these fields to Batswana experts.

Mr. R. C. Gabonowe drew the attention towards the last 10-year increase in the vehicle park in Botswana, especially in Gaborone. The vehicle park has increased 10 times during the last decade with the negative effects the increased emissions have on the local air quality.

The last remarks by Mr. R. C. Gabonowe was to the old way of solving the problem with air pollution:

SOLUTION TO POLLUTION IS DILUTION.

During the 1960s and 1970s most factories were allowed to emit at high altitudes (tall stacks). However, now they know that what is emitted into the atmosphere will eventually come down to the earth's surface in one way or another, either as deposition or as acid rain, and that after this project they will have the knowledge to monitor, analyze and model the air pollution - and to take action to reduce it.

Participants at the seminar

Mr. Bjarne Sivertsen introduced the participants from NILU:

- ⇒ Ms. Tone Bekkestad : Project manager. Modelling and statistics.
- ⇒ Mr. Svein Knudsen : Modelling and statistics.
- ⇒ Mr. Ove Hermansen : Chemical analysis.
- ⇒ Mr. Rolf Dreiem : Instruments.

Mr. B. Sivertsen then gave a short presentation of NILU and the other environmental institutes in Norway (NIVA, NINA, NIKU), and stressed that quality assurance (QA) will be an important part of the project here in Botswana. Mr. Sivertsen also expressed that the initiation to this co-operation was a result of a project with the SADC-countries 4 years ago.

Ms. Britt Hilde Kjølås (First Secretary at the Norwegian Embassy in Botswana) introduced herself and NORAD (Norwegian Agency for Development Co-Operation).

Mr. Choma J. (Principal air quality inspector) introduced the participants from DoM:

- ⇒ Mr. R. C. Gabonowe : Chief governmental mining engineer.
- ⇒ Mr. Moabi D. Mmolawa : Instruments.
- ⇒ Mr. Tioroyaone Tshukudu : Computer specialist, modelling.
- ⇒ Mr. Selogilwe M. Mosinyi : Technical assistant in laboratory (Collects samples, ensures that they are collected properly).
- ⇒ Mr. Albert Mukuwa : Mechanical electrical officer, instruments (Selebi Phikwe).
- ⇒ Mr. Mothusi Sereetsi : Instruments, field personnel. Supervisor for office in Selebi Phikwe.
- ⇒ Ms. Kene C. Lenyatso : Chemist.
- ⇒ Ms. Gorata L. Motshwane : Just finished high school. Now at DoM (air pollution control division) to serve her civil service which contains a one year training with an institution/department. She will be "floating around" to get a total picture.
- ⇒ Mr. Kabelo K. Mogami : Leading chemist (Analysis).
- ⇒ Ms. Orabile M. Serumola : Environmental engineer/water pollution engineer (waste water from mining).

- ⇒ Ms. Lesego Modisane : Chemist. Trainee. (Selebi Phikwe).
 ⇒ Mr. Hentie J. P. Hough : Representative from the Ministry of
 Mines, Namibia.

See participant list in Appendix C for further information on addresses and telephone numbers, etc.

Mr. B. Sivertsen opened the lectures giving a short presentation of all the subjects that should be covered during this 5 day seminar. The topics of the seminar were:

- Air Quality Indicators
- Monitoring Program
- Meteorology
- Air Pollution Modelling
- Data Presentation
- Impact Assessment

Mr. B. Sivertsen summarized the day's session with some questions pinpointing the highlights of the lectures. Mr. Mukuwa and Mr. Matale contributed with a lot of interesting questions throughout the session.

2.3 Tuesday 5 November 1996

Mr. C. J. Matale opened the second day of the seminar commenting yesterday's interesting lectures before handing "the floor" to Mr. Bjarne Sivertsen.

Mr. B. Sivertsen started the day's lecture repeating some of the basic points from yesterday pointing out the importance of quality assurance and quality control (QA/QC).

QA

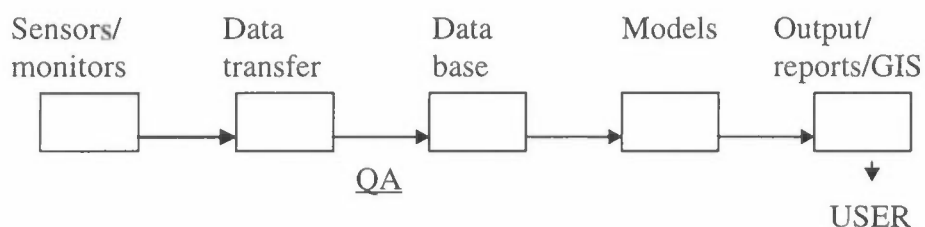

Mr. B. Sivertsen then gave a brief overview of the lecture's highlights throughout the day which was primarily concerned with the following three subjects:

- What?
- Where?
- How?

Mr. B. Sivertsen continued summarizing some of the basic points of environmental indicators such as:

- What kind of air quality indicators (AQIs) are needed?
- Criterias for selection of AQIs

After a short break Mr. B. Sivertsen continued explaining and defining air quality guidelines (AQG) and standards. DoM had a lot of interesting questions at this point clarifying i.e. the difference between short and long term indicators/effects/AQG-values. Mr. B. Sivertsen then pointed out the most important AQI for urban areas which should be used in Botswana (SO₂, NO₂, PM₁₀ (PM_{2,5}), O₃ and CO).

Mr. R. Dreiem continued after a 20 minute coffee break describing the most important factors in siting and siting studies.

After a short break Mr. O. Hermansen explained the different analytical methods used at NILU for SO₂, NO₂, particles and precipitation (cations, anions). Different types of monitoring equipment were then presented by Mr. R. Dreiem.

Mr. B. Sivertsen rounded off Tuesday's session with a presentation on air quality assurance, data storage and a round on questions from the participants.

2.4 Wednesday 6 November 1996

Mr. B. Sivertsen started Wednesday's lecture repeating some of the highlights from yesterday's lecture.

Ms. Tone Bekkestad then gave a presentation on the basic theory of meteorology, the importance and use of meteorological data, and an introduction to transport, turbulence and diffusion. There were a lot of questions from the participants during this presentation, because this was a new subject for most of the participants.

After the morning coffee break Mr. Svein Knudsen presented the major aspects of emission estimates, air pollution modelling (ROADAIR, CONTILINK, CONCX, KILDER) and emission data bases. The air pollution models were divided into classes based on the following:

- Gaussian
- Box
- Statistical
- Numerical
- Trajectory

After lunch Mr. S. Knudsen continued presenting the different types of models that NILU use for dispersion calculations from point, area and line sources.

Mr. B. Sivertsen continued after a short afternoon break giving examples on how some of the models work, the interpretation of the results and rounded Wednesday's session off with questions to the participants regarding today's lectures.

In the evening the Norwegian participants (NILU), Mr. C. J. Matale and Mr. R. C. Gabonowe (DoM) were invited for dinner with Chargè d'Affaires Oskar Oskarsson and First Secretary Britt Hilde Kjølås.

2.5 Thursday 7 November 1996

Mr. B. Sivertsen summarized the last three days in three points;

- What? Indicators:
 - * SO₂ (BCL, Selebi Phikwe)
 - * NO₂ (Traffic, NO (95%), NO₂ (5%))
 - * CO (Traffic)
 - * Lead (Traffic)
 - * CO₂ (Fossil fuel. Not important locally. Most important global pollutant)
 - * O₃ (HC+NO_x+O₂⇒O₃) Slow transformation. O₃ formation a summer/daytime problem (need sunlight).

- Where?
 - * Street (lead, CO, NO_x, PM₁₀) (NMHC, O₃)
 - * Urban (SO₂, NO₂, PM₁₀/PM_{2,5}, Mr. B. Sivertsen)
 - * Residential (SO₂, NO₂, PM₁₀/PM_{2,5}, Mr. B. Sivertsen)
 - * Industrial (SO₂, TSP→element analysis (Ni, Cu, Ar) depend on type of industry)
 - * Background (O₃, precipitation (analyze for chem. comp.), SO₂)

- How?
 - * Samplers (Individual, Sequential)
 - * Monitors

After the morning coffee break Mr. B. Sivertsen talked about data evaluation, trend analysis and presentation (air pollution statistics, use of meteorological data and air quality data interpretation):

- time series
- scatter plots
- cumulative frequency distribution
- Breuer diagram
- trend analysis
- average concentrations vs. time
- joint frequency distributions.

After lunch Mr. B. Sivertsen showed different ways to present measured and estimated data (scatter plots, tables, cumulative frequency distributions, Breuer diagram, etc.).

Mr. B. Sivertsen continued after a short afternoon coffee break to talk about environmental impact assessment (EIA), critical loads, health effects, etc.

2.6 Friday 8 November 1996

Mr. B. Sivertsen started the last day of the seminar asking the participants whether there were any subjects that had not been covered properly during the last four day seminar, or if there were something that should be repeated or covered in more detail. One of the questions was to repeat the classification of different types of particles. Particles are commonly divided into 3 groups:

- dustfall ($>PM_{10}$)
- inhalable (PM_{10})
- respiratory ($PM_{2,5}$)

Mr. B. Sivertsen continued explaining the main features of environmental impact analysis (optimal abatement and strategy planning) and air quality management strategy, presenting an example on emission inventorying and AQ monitoring in Bombay.

After the morning coffee break the content of an annual report was discussed. Mr. B. Sivertsen showed an example of an annual report from the State Pollution Control Authority in Norway (SFT). The annual report for Botswana should contain:

- Industrial pollution
- Traffic
- Urban/residential air
- Acid rain
- Tropospheric ozone
- Vertical distribution of ozone layer
- (Climate change)

All the above topics should contain description of:

- Goals
- Current trends
- Outlooks

The closing of the seminar was performed by Mr. Oskar Oskarsson (Chargè d’Affaire at the Norwegian Embassy), together with Ms. Britt Hilde Kjølås (First secretary at the Norwegian Embassy) and Mr. Choma J. Matala (DoM). Before the formal closing of the seminar Mr. B. Sivertsen summarized in a formal manner what had been the basic points of the 5 day seminar on Air Quality Monitoring Systems and its Applications.

In the closing speech Mr. Oskarsson stressed the two words co-operation and co-financing. The co-operation of this project lasts for more than the 5 days of the seminar and will hopefully result in a long term relationship and mutual co-operation between the two countries of Norway and Botswana. A special thank to DoM for arranging the seminar was also given before Mr. Oskarsson declared the seminar for closed and the “kick-off” of the project fulfilled.

The seminar was ended with the Chargè d'Affaires giving out certificates of attendance to the participants.

3. Site visits to sampling stations in Botswana

3.1 Site visits

The sampling stations operated by both the Department of Mines (DoM) and the (BCL) smelter in Bamangwato Concession Limited in Selebi-Phikwe were visited during the second week. Figure 1 shows the distribution of air quality monitoring sites in Botswana. From the site visits we produced site visit reports presented in Appendix F. Some of the towns/villages found in Figure 1 contain more than one monitoring site. The exact location of the stations can be found in Appendix F.

The sites owned and operated by BCL were visited together with Mr. Jo Madumela, who is the main responsible for air quality measurements and analysis at the BCL laboratory; Mr. Albert M. Mukuwa and Mr. Mothusi Sereetsi, responsible for the air quality measurements and analysis at the DoM laboratory in Selebi Phikwe; Mr. Moabi Donald Mmolawa, responsible for the monitoring stations in Gaborone and Lobatse; and Mr. Choma J. Matala Principal air quality inspector at DoM.

The sites visited are presented in Table 1 together with the site owner and their position given in UTM reference co-ordinates. The UTM co-ordinates are found from 1:50.000 scale maps. The exact UTM co-ordinates will later be found by using a Global Positioning System (GPS). This work will be done by DoM.

Most of the maps were achieved from the Department of Survey and Mapping in Gaborone. City maps with street names (without co-ordinates) were used to locate the stations on the 1:50.000 scale maps. The city map for Selebi-Phikwe was given to us by Mr. Lawrence G. Mosweunyane (environmental engineer at the BCL Limited).

The siting of most of the stations was good and representative for urban, residential and industrial areas. The reason for the extensive monitoring program in Selebi-Phikwe compared to the other monitoring locations around in Botswana, is the large emissions from the BCL smelter. The smelter emits approximately 280 000 tonnes SO₂/year. The BCL smelter is the largest single source in Botswana and burning of vegetation due to high SO₂ concentration is likely to occur.

Production data, emission rates and stack parameters for the emissions from the BCL stack is achieved from Mr. Lawrence G. Mosweunyane (environmental engineer at the BCL Limited), who was very helpful when we visited BCL Limited.

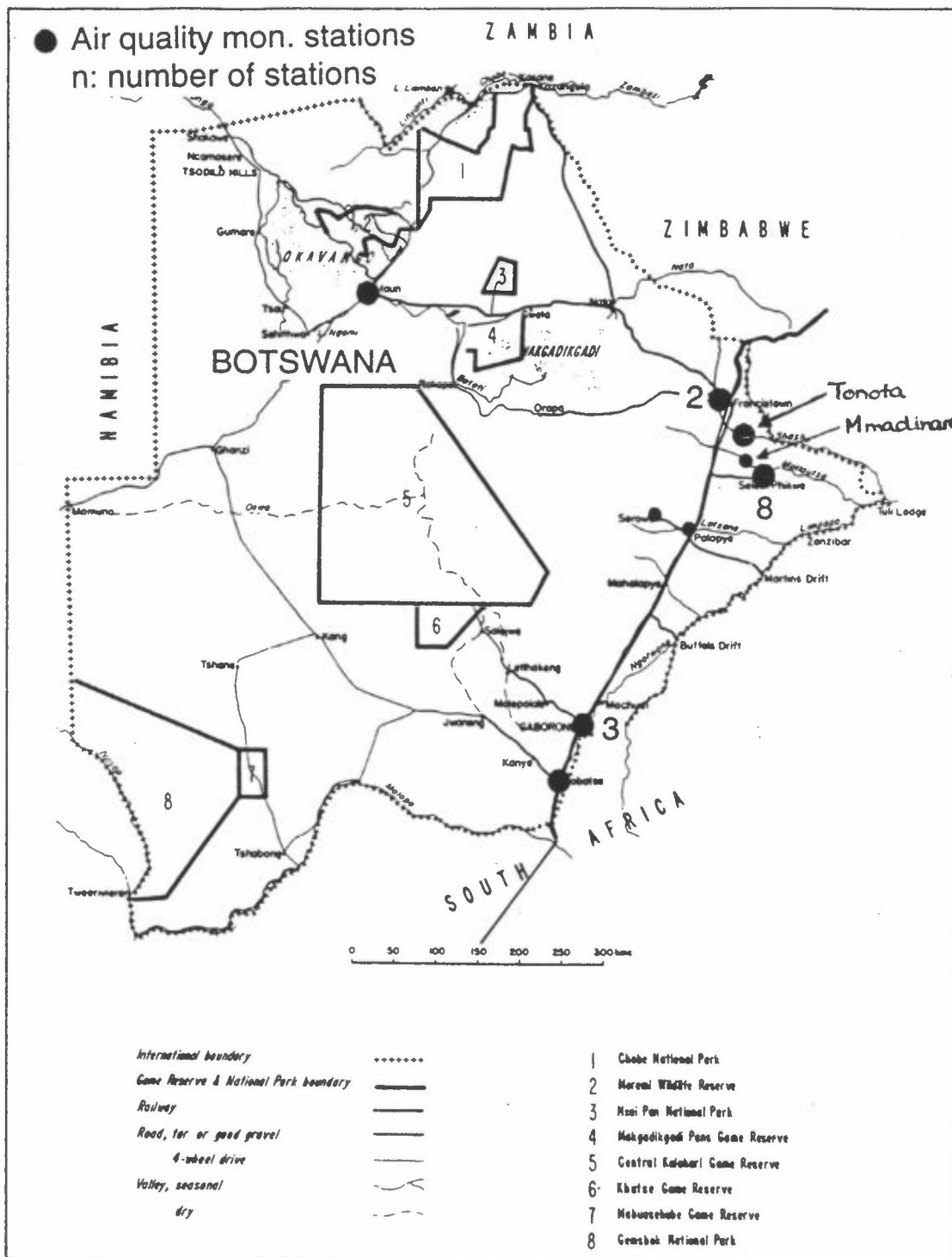

Figure 1: Location of monitoring sites in Botswana.

Table 1: Air quality monitoring sites in Botswana with locations given in UTM reference co-ordinate locations.

Site name	Place	Site owner	UTM (from map)	
			X	Y
DoM Laboratory	S. Phikwe	DoM	355,865	3,575,709
Botshabelo Police Station	S. Phikwe	BCL	355,899	3,575,702
Hospital	S. Phikwe	BCL	355,864	3,575,706
BCL Clinic	S. Phikwe	BCL	355,868	3,575,705
Low Density	S. Phikwe	BCL	355,872	3,579,691
Railway station	S. Phikwe	BCL/DoM	355,844	3,575,714
Railway track	S. Phikwe	DoM		
S. Phikwe Sec. School	S. Phikwe	DoM		
Township West	S. Phikwe	DoM		
Water Utility Co	S. Phikwe	BCL	355,886	3,575,746
Makobe Hill, Jr. Sec. Sc	Mmadinare	DoM		
Possible Curb-side St.	Francistown	DoM	355,521	3,576,599
Francistown Town Council	Francistown	DoM	355,520	3,576,600
Francistown Airport	Francistown	Met. Office	355,506	3,576,602
Tonata	Tonata	DoM		
Palapye Primary Hospital	Palapye	DoM		
Serowe Teacher Tr. College	Serowe	DoM	354,684	3,575,231
Lobatse	Lobatse	DoM	353,659	3,572,091
Civic Center	Gaborone	DoM	353,907	3,572,728
Therisanyo Prim. School	Gaborone	DoM	353,891	3,572,704
Gaborone Fire Brigade	Gaborone	DoM	353,888	3,572,728

The stations are generally well located. At some stations, however, there is too much vegetation around the monitoring site (the air intake). This can be solved placing the air intake higher above the ground (generally 2-3 m above ground) and away from building walls, brick fences and nearby vegetation in accordance with the general specifications. Most of the intakes must be improved if the sites are to be used for future monitoring.

Monitoring stations

The monitoring stations generally have good technical equipment. However, there are no calibration possibilities at the stations in Mmadinare and Tonota (Monitor Lab equipment). The monitoring station in Serowe has good technical equipment from Horiba. The Horiba instruments were new.

The meteorological towers were generally too low. The meteorological towers at Mmadinare and Tonota were not rigged properly. The wires for supporting the top of the tower were missing. This causes the tower to vibrate, which again will affect the horizontal standard deviation of the wind direction, which is a measure for turbulence. In Serowe, however, the meteorological tower was properly rigged. Although the meteorological tower was too short, this was the best location of the meteorological measurements in a relatively flat, homogenous

terrain. In Selebi-Phikwe there was a meteorological tower outside the DoM laboratory. This was not in operation.

The data collection procedures of the monitoring stations were generally good. The data were stored both on the hard disk at the monitoring station, on a hard disk in the laboratory in Selebi-Phikwe, and on diskettes. At the Horiba station in Serowe the data were only on the hard disk. The reason for this is that the software that is used to extract the monitored data is only installed on this computer. Hence, there is no backup of the data on the Horiba station. None of the stations had any routine for logging of data.

SO₂ bubblers

In Selebi-Phikwe the stations were located in the predominant wind direction from the BCL in the maximum areas for diffuse emissions and emissions from the stack plume. Most of the stations used the British produced sequential 24 h average SO₂ sampler from AGL Engineering. The samplers are built into a wooden box. Each wooden box contains 4-8 samples. The maintenance and the state of the sequential samplers was generally poor. The tubes should be replaced with Poly Carbonated tubes, which absorbs less SO₂. Also, the tubes should, if possible, be shorter.

The stations in Selebi-Phikwe owned by DoM with only 4 bubblers on each site were not running at the moment. The reason for this was that Mr. Mukuwa and Mr. Sereetsi the last week had joined the seminar on Air Pollution Monitoring and its Applications held by NILU in Gaborone. Since they are the only ones responsible for the sampling and analysis in Selebi-Phikwe there are no one to do the sampling if they are not present.

The wooden boxes that are used for the bubblers does not seem to be cleaned regularly and some were placed more or less directly on the sandy ground. The boxes seem to have been out in the field for several years without cleaning. A general comment to this is that the boxes should be placed higher above the ground both for the working environment and to reduce the possibility of contaminating the samples, and that they should be cleaned regularly.

Sierra high volume samplers

The Sierra high volume samplers were generally also too dirty. They should be taken back to the laboratory for cleaning at least once per year. Normally the filter backing/filter holder shall be cleaned every time the filters is changed (once a week). The samplers should be moved away from local dust sources such as dirt/gravel roads.

3.1.1 Selebi Phikwe

Bubblers

All the bubblers were British made AGL 24 hours sequential samplers consisting of 4 or 2x4 bottles. The air volume is an average of the total sampling time (3 or 7 days).

The wooden boxes covering the sampler was in poor conditions and should be repaired/upgraded as soon as possible to prevent dust to enter the sampler.

The air inlets were generally in poor condition and the length of the air inlets varied from 5 cm to 3 m long, and between 75 cm and 3 m above ground. This has to be corrected to international standard (2 m above ground, and at least 1 meter away from walls, roofs and leaves). The air inlets were often located under roof. The funnels were also in bad condition or missing. The funnels presently in use must be replaced with new funnels.

The tubings inside the bubbler has to be replaced by new ones (polycarbonat or heavy wall silicone tubing) that do not collapse due to underpressure in the system.

High Volume samplers

The high volume samplers (Hi-Vol) used to measure PM₁₀ and TSP were Grasby Andersen model 2000. The Grasby Andersen samplers were running in sequence of 4 hours a day, 6 days per week. The Partisol sampler was not in operation at present. New filters have been ordered from South Africa but not yet delivered.

The Grasby Andersen samplers (TSP) generally needed cleaning, flow control and adjustment.

The location of the samplers were generally not good. Most of the samplers were located along building walls (approximately 20 cm away) and close to gravel roads. The location of the samplers close to the road might lead to too high dust collection originating from the road and is therefore only representative for road dust.

Monitors

The monitors (analysers) presently in use are SO₂, NO_x, CO, CH₄ and NMCH.

The monitor park consists of instruments from Monitor Lab, Horiba, Dasibi Byron, API and TE (Termo Elektron).

The location of the monitors were generally very good. All sites had air conditioned caravans to keep the temperature constant.

All air inlets were made of good materials and U-shaped so that they matched international standards. The inlets made of glass needed cleaning.

A fan was connected to the inlets to keep the flow high (correct flow rate). All the tubings inside were made of teflon.

All the analysers were in good working condition except for two SO₂ analysers at the laboratory in Selebi Phikwe. These two SO₂ analysers were stored at the laboratory uncalibrated, without calibration equipment.

There is calibration gas only at the Horiba station at Serowe (single point gas blender). At the other stations span check was performed by permeation tube. The last calibration was performed in March 1996 by a South African company.

The monitoring data were recorded at different intervals (1-3) weeks from the stations on diskettes and brought to the laboratory for plotting and storing. At the Horiba station the data were collected on paper prints only. This is because this is the only station (PC) with the Horiba software for plotting of measured data installed.

Meteorology

The meteorological equipment is generally in good working condition except at the laboratory in Selebi Phikwe where the meteorological station (data) is not logged.

The height of the meteorological towers is generally too low, and the masts are not rigged properly.

The meteorological data are collected together with data from the monitoring station.

3.1.2 Gaborone

Bubblers

All the bubblers were British made AGL 24 hour sequential samplers consisting of 4 or 2x4 bottles. The air volume is an average of the total sampling time (3 or 7 days).

The steel boxes covering the samplers were generally in poor conditions and should be made dust proof as soon as possible to prevent dust to enter the sampler.

The height above ground of the air inlet at the station in Lobatse was too low. This has to be corrected to the international standard (2 meters above ground and at least 1 meter away from walls, roofs and leaves). The funnels were also in bad condition and must be replaced.

The tubings inside the bubbler have to be replaced by new ones (polycarbonat or heavy wall silicone tubing) that do not collapse due to underpressure in the system.

High Volume samplers

The high volume samplers (Hi-Vol) were of the Sierra and Graseby type PM₁₀ samplers. The Sierra samplers were running in sequences of 4 hours a day, 6 days per week.

The Sierra samplers (TSP) generally needed cleaning, flow control and adjustment.

The location of the samplers were good.

Monitors

The monitors (analysers) presently in use are SO₂, NO_x, CO, CH₄ and NMCH. The monitor park consists of instruments from Monitor Lab and Dasibi Byron.

The locations of the monitors were very good. All sites had air conditioned caravans to keep the temperature constant.

All air inlets were made of good materials and U-shaped so that they matched international standards. The inlets made of glass needed cleaning.

A fan was connected to the inlet to keep the flow high (correct/constant flow rate). All the tubings inside were made of teflon.

All the analysers were in good working condition.

At the stations span check was performed by permeation tube. The last calibration was performed in June 1996 by a South African company.

The data were collected every day from the monitoring stations on diskettes and brought to the laboratory for plotting and storing.

Meteorology

There is at present no meteorological stations running in the Gaborone/Lobatse area.

3.2 Air Quality data retrieval and storing

3.2.1 Emission inventory

Existing data on emission data in Gaborone was discussed with Mr. Choma J. Matala and Mr. Tiroyaone Tshukudu at Department of Mines Thursday 14 November 1996.

Department of Mines, under the supervision of the Principal air quality inspector Mr. Choma Matala, is at the moment undertaking an emission inventory study for Botswana. The Gaborone emission inventory is planned to be finished in December 1997. The data will be stored in DBASE 3 and will be connected to the GIS system ARCVIEW.

The emission inventory will contain data for consumption of oil, gas and coal from industries and institutions in the country. Institutions is in this context referred to as official institutions, restaurants and small scale industry. The inventory will not include area sources and consumption statistics for calculating emissions from domestic use of fossil fuels. The inventory will not cover emissions from traffic. Traffic is the main source for air pollution in some of the major cities in Botswana.

3.2.2 Future work on emission inventories

The emission inventory should include a national inventory which summarizes the emission on the national scale. The next level include splitting on the different activities such as industry, traffic etc. This splitting can also be done for the different geographical areas of the country.

A very important issue with the emission inventory is quality assurance and quality control (QA/QC). Emission inventories have to be checked through sales statistics on the different types of fossil fuels. This way it is possible to control that the inventory covers the total consumption of the different fossil fuels.

To get the traffic emissions it is necessary to use a model. The data needed for this are traffic countings or a traffic model of the type that is used by city planners. The model calculate emissions along a road network based on traffic intensity, road lengths and emission factors.

A complete emission inventory is needed to be able to establish air quality abatement strategies.

3.2.3 Available air quality data from monitors

Department of Mines have several monitors in and around the main cities and around the large industries in the country. The stations are not at present connected to a central computer via networks. Personnel from DoM go and make a copy of the data on a diskette and bring this back to a central computer for treatment. These procedures are different from station to station because the different stations have different suppliers and therefore use different software to treat the data. In general the data from the monitoring stations in Gaborone (Civic Center and Fire Brigade) are collected every day and time plots of each parameter is produced every day. The data from the stations in Mmadinare, Serowe and Tonota are collected once a week. The data are treated in Selebi Phikwe.

3.2.4 Missing data handling

Missing data is given the value of 9999 by the system. Data that is clearly wrong (according to quality control procedures) must be substituted with 9999 after the quality control at the station and before the data is stored as official data. The data that are given as missing data by the logger program is kept as 9999 today, but there are no procedures on how to treat erroneous data but are not recorded as 9999 by the system.

3.2.5 *Data storing*

The data are stored in flat files as original files from the logger program and as processed files. The files are stored at several locations.

- In Gaborone, the files are stored at a central computer at DoM (Civic Center and Fire Brigade) and on the hard disk at the monitoring station.
- In Selebi Phikwe the data from the stations Tonota and Mmadinare are stored at the stations and at the Selebi Phikwe laboratory.
- The data in Serowe is only stored at the station. This station have a different software for processing the data and the instruments are from another supplier. For convenience these data are processed at the station and stored there.

The data files have different conventions for storage:

- In Gaborone the Civic Center files are stored as CCXXX.xls, where CC denotes Civic Center and XXX Julian day. At the Fire Brigade the CC is substituted with FB.
- At Mmadinare the files are called rep_aXXX.dat and at Tonota rep_bXXX.dat where XXX is Julian day and a and b refers to the respective stations.
- At Serowe the files are stored under month name in EXCEL files.

3.2.6 *Statistical programs*

DoM is at present using three types of programs for statistical treatment of the measured data. The spreadsheet EXCEL is used for plotting of time series. The EXCEL spreadsheet is also the format the data are stored as in the files used for statistical treatment. The plots of the different days are also stored in these files.

The equipment made by Monitor Labs are treated in a program called ENVAID. This program has various options for statistical treatment:

- Wind roses
- Pollution roses
- Histograms (frequency distributions)
- Special reports (change of format)
- Statistics (mean, sigma's, percentile)
- Scatterplots
- Diurnal plots
- Time versus value plots
- Change of averaging time
- Pollutant standard
- Index files

The ENVAID program together with the EXCEL spreadsheet has got the possibilities to treat the measured Monitor Lab data and the Young meteorological data adequately.

For the data measured by HORIBA (Air Quality data) and Aanderaa (meteorology) the data are given by the logger program on a form that can be read directly into EXCEL. The HORIBA station at Serowe comes with an EXCEL spreadsheet that is equipped with macros that calculate basic statistics such as; number of observations averages over the period, minimum and maximum values, and standard deviation of the parameter for a given periods. In addition to this the meteorological data can be treated in LABVIEW, but special procedures for this must be developed. LABVIEW can provide wind roses.

3.3 Air quality measurements

Table 2 gives an overview of the different stations and parameters measured in Botswana. Some possible locations that does not have measurements at the moment is also included for possible use later in the project.

Table 2: Parameters measured at the sites visited. FF denotes wind speed, DD wind direction, Rh relative humidity, sig. standard deviation of wind direction, TSP total suspended particles.

Site name	Place	Site owner	Air quality	Meteorology
DoM Laboratory	S. Phikwe	DoM		
Botshabelo Police Station	S. Phikwe	BCL	SO ₂	
Hospital	S. Phikwe	BCL	SO ₂	
BCL Clinic	S. Phikwe	BCL	SO ₂	
Low Density	S. Phikwe	BCL	SO ₂	
Railway station	S. Phikwe	BCL/DoM	SO ₂ , TSP	
Railway track	S. Phikwe	DoM	SO ₂ , TSP	
S. Phikwe Sec. School	S. Phikwe	DoM	SO ₂	
Township West	S. Phikwe	DoM	SO ₂	
Water Utility Co	S. Phikwe	BCL	SO ₂	
Makobe Hill, Jr. Sec. Sc	Mmadinare	DoM	SO ₂ , CO, PM ₁₀	FF, DD, sig., T, Rh
Possible Curb-side St.	Francistown	DoM	-	-
Francistown Town Council	Francistown	DoM	SO ₂ , TSP	
Francistown Airport	Francistown	Met. Office		FF, DD, sig, T, Rh, radiation, pres.
Tonata	Tonata	DoM	SO ₂	FF, DD, sig., T, Rh
Palapye Primary Hospital	Palapye	DoM	SO ₂	
Serowe Teacher Tr. Collage	Serowe	DoM	SO ₂ , NO _x , NO, NO ₂ , CO	FF, Gust, DD, T, Rh
Lobatse	Lobatse	DoM	SO ₂	
Civic Center	Gaborone	DoM	SO ₂ , NO, NO _x , NO ₂ , O ₃ , CH ₄ , NMVOC	
Naledi (Th. Prim. School)	Gaborone	DoM	SO ₂	
Gaborone Fire Brigade	Gaborone	DoM	CO, NO, NO ₂ , NO _x , CH ₄ , NMVOC	

Sequential samplers

Samples from the sequential samplers are analyzed at the laboratories in Selebi Phikwe and Gaborone. The data are treated manually and are not on files in a systematic way. Because of the chemical method used for analysis the data have a poor quality.

Problems with data storage

The analysis of the data show a lack of consistency in storing the data. The data should to be stored at one location and with a unified system of storing with backup procedures. The analysis of data show that the data are stored in files and plotted. If non valid data is found the data is not corrected. This will affect the statistical treatment of data at a later stage. Procedures must be implemented to ensure that the data used for statistics are quality checked. The original data must also be stored.

Measurements of meteorology

There are presently measurements of meteorology at three stations. These are Mmadinare, Tonota and Serowe. The measurement equipment seem to be functioning well. The standard deviation of wind direction measured at Tonota and Mmadinare are quite high which indicates a high occurrence of unstable atmospheric conditions. The diurnal cycle of the turbulence and temperature is as expected. The wind speeds are generally low. The maximum wind speed recorded at Tonota was 9 m/s, and the most frequent wind direction is winds from west to south west. The wind at Mmadinare have the same characteristics as Tonota. Only one month of data was available at Serowe and these data look good.

Brief analysis of Air Quality measurements

The analysis of air quality will concentrate on the measurements done by monitors. The analysis of the data from the sequential samplers are not treated here because they are sufficiently treated in the annual report issued by DoM. The annual report for 1993 is enclosed.

Tonota

The SO₂-data from Tonota for the months April, May, June and July 1996 are not valid data and have to be removed from the final data. Data for other months that are available looks good and clearly shows the impact from a large point source. This can be seen by the normal low concentration and the episodes with relative high concentration as seen in Figure 2.

These high concentrations occur with wind direction from East to South as seen from Figure 3 .This is the direction towards the BCL smelter in Selebi Phikwe. The highest ground level SO₂ concentrations occurred with wind from the east and was slightly under 80 µg/m³.

Tonota August 1996

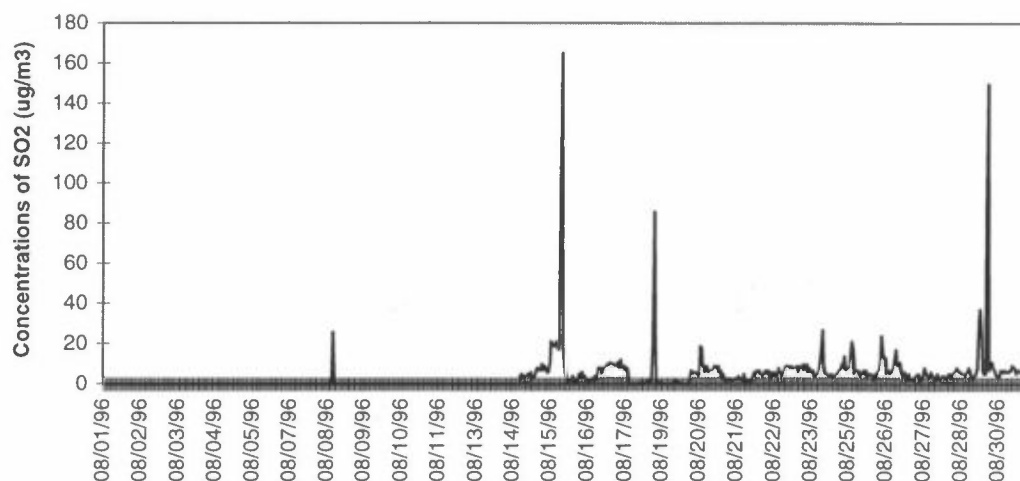

Figure 2: Concentrations of SO_2 at Tonota in August 1996.

Tonota October 1996

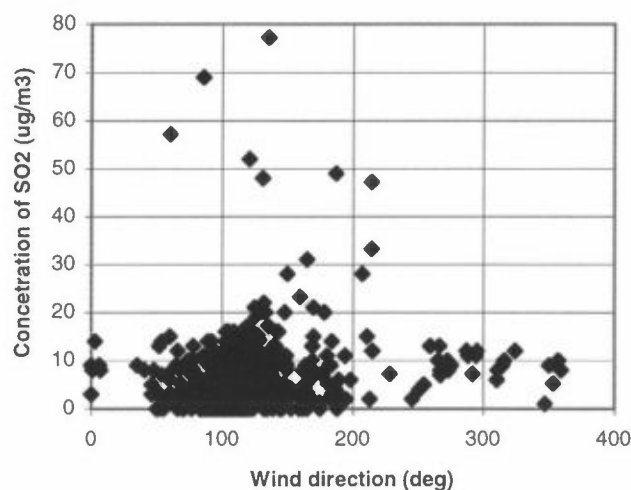

Figure 3: Measured concentrations of SO_2 at Tonota as a function of wind direction.

Mmadinare

The SO_2 concentrations at Mmadinare have the same characteristics as at Tonota. However, the concentrations are higher because the station is closer to BCL. At Mmadinare there is also measurements of CO. These show that the CO concentrations are close to zero with some small peaks that are most likely caused by local sources.

From the Serowe station only data from October 1996 was presented to us. These show that there is a substantial amount of SO_2 at the station (approximately $260 \mu\text{g}/\text{m}^3$ as an 1 hour average). The station is also equipped with a NO_x monitor. These measurements show only a small amount of NO_x (approximately $30 \mu\text{g}/\text{m}^3$) and the NO_2 concentrations were very low the whole month. The SO_2 concentrations are probably coming from the powerplant between Palapye and Serowe.

The three stations Tonota, Mmadinare and Serowe show impact from plumes emitted some distance away.

Gaborone

In Gaborone there are two monitoring stations (Civic Center and Gaborone Fire Brigade). Both stations are located close to roads and show a clear impact from traffic. Measurements from these stations show clear diurnal cycles with high concentrations in the morning and evening rush hours during workdays. A typical diurnal cycle is presented in Figure 4. For weekdays and public holidays the diurnal cycle is different and not so pronounced.

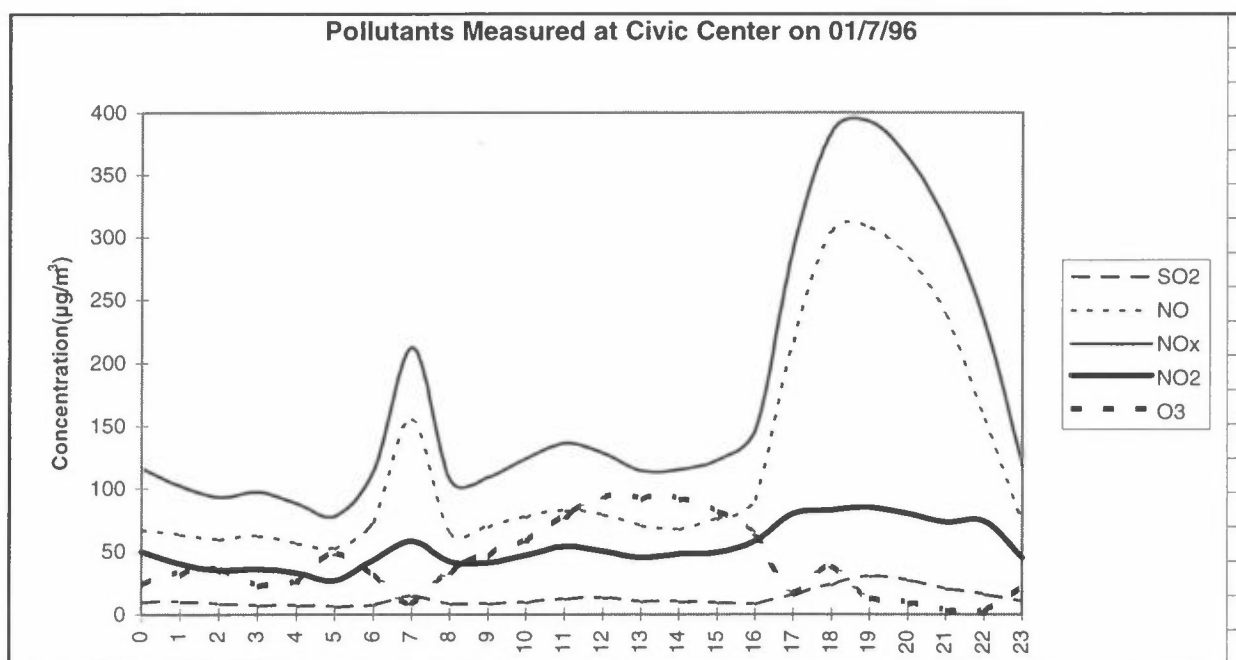

Figure 4: Typical diurnal variation of pollutant concentrations for a work day at Civic Center, Gaborone, July 1996.

Plotting SO_2 concentrations versus NO_x concentrations, SO_2 is an indicator for industry and diesel cars. In a scatter plot it is seen that the data group into two groups (Figure 5). One of the groups is related to traffic (NO_x) and the other is related to a source with low NO_x emissions compared to SO_2 emissions. In this case, this is probably the boiler of the nearby hospital.

The measurements at the Fire Brigade did not show any obvious statistical characteristics and simultaneous meteorological measurements will be needed for such an analysis.

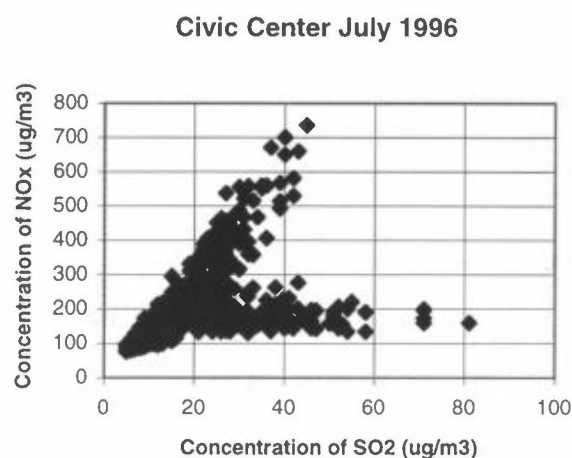

Figure 5: Simultaneous measurements of NO_x and SO₂ at the Civic Center, Gaborone, in July 1996.

4. Future air quality monitoring program. Preliminary Proposal

4.1 Strategy

The monitoring sites for the future national air quality monitoring program is selected based upon available information on:

- monitoring objectives,
- meteorological conditions, prevailing winds,
- existing data,
- major air pollution sources.

The measurement sites will cover different scales of air pollution, as stated in the international requirements for air pollution monitoring (UNEP/GEMS program);

- central urban roads and street canyons (curb side),
- urban scale regions and residential areas,
- industrial areas,
- background areas.

Different air pollution indicators will be measured at the different sites dependent on the specific sources and the problems at that site.

The first priority air pollutants as presented by UNEP/GEMS, WHO, OECD and others are:

- Sulphur dioxide (SO₂),
- Total suspended particular matter (TSP), or better PM₁₀ (suspended particles with a diameter less than 10 micrometers),
- Nitrogen dioxide (NO₂) and nitrogen oxides (NO_x),

- Ozone (O₃),
- Carbon monoxide (CO).

Not all parameters will be measured at all sites. This will depend upon site specifications and typical dominating sources. At some sites also dust fall could be measured on a monthly basis with simple dust fall collectors.

Meteorological data on an hourly basis will be needed to explain the air quality data collected. Wind speeds, wind directions and atmospheric turbulence (stability) are the most important parameters.

As part of the monitoring program a few automatic weather stations (AWS) will be established at representative air quality monitoring sites. At present there are three meteorological monitoring sites in Botswana operated by DoM. These locations have been evaluated for the new national monitoring program for Botswana.

4.2 Site selection

Measurements with passive samplers

To evaluate the representativeness of some of the monitoring sites, simplified field studies using inexpensive samplers should be applied after the first screening study performed in November 1996. The samplers should measure at least two months and be analyzed at NILU. The first week of February 1997 will be suggested for such a study combined with the yearly meeting between NORAD and DoM, where Ms. Tone Bekkestad from NILU will be attending as an observer.

The results from this study will act as additional information to the proposed future monitoring program for Botswana, and may imply changes in the proposed program.

Site visits

The sites visits reported in chapter 3 and Appendix F, represent the main basis for the proposed new national monitoring program for Botswana. These sites represent the measurement program operated by Department of Mines (DoM) and also the sites operated by BCL in Selebi-Phikwe. The sites in Selebi-Phikwe have mainly been selected for evaluation of health impact as a result of emissions from the BCL smelter.

Some of the sites represent different area types, and where locations, representativeness and infrastructure have been found adequate, the sites have been selected also for the future modernised national monitoring program for Botswana.

Air quality and important emission sources

Available air quality data and subjective information about major air pollution sources have also been used to select sites for the future air pollution monitoring program in Botswana.

One of the major air pollution sources in Botswana is the BCL (Bamangwato Concessions Limited) copper smelter in Selebi-Phikwe, approximately 400 km northwest of Gaborone. Average emissions from the 152 m tall BCL-stack (furnace) is approximately 280,000 SO₂ tonnes/year. In addition there are 2 smaller stacks and also substantial diffuse emissions. See Appendix V for further information on emissions and also information on the monthly coal consumption for the different processes for January to September 1996. Selebi-Phikwe is a fairly small industrial town and is not considered to have any major problems as a result of emissions from vehicles. Hence, the main concern here are the emissions from the BCL smelter. Estimated ground level SO₂ concentrations show that the SO₂ level is higher than the guidelines presented by World Health Organization (WHO).

For Gaborone, traffic is one of the major sources for air pollution. Extensive use of vehicles; a high percentage of diesel cars/trucks and many non-catalyst cars. This problem is mainly confined to the main roads in the city center, where the density of the traffic is substantial during the morning rush hour, the lunch hour rush and the evening rush hour. The highest impact can be seen as a result of the evening rush hour when the atmosphere stabilizes and the vertical mixing of the ground level pollutants is restricted by the stably stratified atmospheric layer.

In Francistown, industry and traffic are expected to be the major sources for air pollution to the atmosphere. This represent a large area with various types of industries.

For most of the measurement sites (cities, villages) the major problems is burning of waste in the late afternoon/evening when the atmosphere stabilizes as a result of sunset and net outgoing radiation. This stably stratified layer set up in the evening resist vertical mixing of the ground level pollution and causes the pollution from waste to maintain in a shallow layer (approximately 50 m) above ground. This effect is most visible in high density areas.

4.3 Preliminary proposed national monitoring program for Botswana. Presented to DoM (C.J. Matala) 22 November 1996

Gaborone:

- | | |
|--------------|--|
| 1 curb side: | CO
NO _x
PM ₁₀ with filter to be analyzed for heavy metals
HC, NMHC
PUF sampler PAH, dioxines |
| 2 suburban: | <u>High density</u>
SO ₂
NO _x
PM ₁₀ with filter to be analyzed for heavy metals
PUF sampler (PAH, dioxines) |

Low densitySO₂NO_xPM₁₀ with filter to be analyzed for heavy metals

PUF sampler PAH, dioxines

I background:

O₃PM₁₀/TSP (with filter to be analyzed in laboratory)NO₂ bubbler (glas filter)SO₂ bubbler

Meteorology:

FF

DD

T

ΔT

RH

Gust

Radiation

Turbulence (σ_u , σ_v and σ_w)**Selebi-Phikwe:**

Max. stack:

SO₂PM₁₀/TSP (analysis at laboratory for heavy metals)

PUF sampler (PAH, dioxines)

Low stack/:

diffuse

SO₂PM₁₀/TSP (analysis at laboratory for heavy metals)

Urban area:

SO₂PM₁₀/TSP (analysis at laboratory for heavy metals)NO_x

PUF sampler (PAH, dioxines)

CO

HC

Suburban area:

SO₂PM₁₀/TSP (analysis at laboratory for heavy metals)NO_x

CO

HC

Background:

O₃

TSP

Meteorology:

FF (2) (minimum 30 m or 36 m tower)

DD (2)

T

ΔT (2)

RH

Radiation

Turbulence (σ_w and σ_v) with GIL-anemometer

Francistown:

Curbside:	NO _x PM ₁₀ /TSP (analysis at laboratory for heavy metals) SO ₂ CO HC
Airport:	O ₃

Power Plant:

Meteorology:	FF DD T ΔT RH Radiation Turbulence
--------------	--

Serowe(?):

Industrial:	SO ₂ O ₃ PUF sampler
-------------	--

Lobatse:

Urban:	NO _x SO ₂ HC Met. ?
--------	--

Maun:

Background:	Precipitation(mm precipitation. Analyze for sumNO ₃ ., sum NH ₄ , pH, cations/anions, Ca, K, Mg, Cl and conduc tivity). Precipitation (Analyze for heavy metals) NO ₂ SO ₂ O ₃ ?
-------------	---

There should be **2-3 more of the background type station** as is proposed for Maun. The exact location for these stations is not yet decided, but Ghanzi might be one possible location. The background stations should be representative for most of the country and should cover the national parks and game reserves.

The total national monitoring program as proposed here summarizes to a total number of monitors as given in Table 3.

Table 3: Total number of monitors and bubblers for the preliminary proposed national monitoring program for Botswana.

Component	NO _x	SO ₂	PM ₁₀	CO	HC	O ₃	Met.
Number of monitors	9	10	9	4	5	4-5	4

5. Field equipment

5.1 Type of equipment needed

Some of the equipment already in use in Botswana can be used in the future national air pollution monitoring program. A discussion of quality of the sampling equipment inspected used in the presented DoM laboratory monitoring program can be found in the site study report given in Appendix F and chapter 3.2.

A complete report on equipment needs with lists including procurement specifications will be developed in February 1997 after discussions with DoM on the details on the future national air quality monitoring program.

5.2 Monitoring station facilities

At some of the monitoring sites selected for the future national monitoring program for Botswana, some of the facilities needed are already available. However, the sites have to be re-visited before installation of expensive equipment.

Each monitoring site should be secured and have (preferably) an air conditioned room, or a place where the room temperature do not exceed 30-35 degrees C.

Power (220 V) and telephone lines have to be available. Power is normally a minor problem. However, new telephone lines have to be ordered and installed at all sites. These also have to be secured and made unavailable for private use.

In some cases a small shelter/box have to be built or purchased for the NO₂ and/or SO₂ bubblers. For the monitoring sites with automatic monitors these shelters have to be of the same size and standard as the one's that are already in use at some of the monitoring stations owned by DoM.

All air intakes have to be standardized and facilities for this will be specified and prepared before the first installation.

6. Chemical laboratory

6.1 Present status

6.1.1 Gaborone

The laboratory in Gaborone consist of a small room in DoM office building. Approximately 500 samples are analysed per year. Water samples are analyzed on metals by atomic absorption (Fe, Cu, Ni, Mn, Co, Cd, Pb, Al) and SO₂ in air is analyzed in bubbler bottles by a pH-titration method. Filters from high volume samplers are weighed on the laboratory balance. Water is purified by distillation and deionising but not checked. A UV-visible spectrophotometer is installed in the laboratory but not in use. A new GC/MS system with cryodesorption equipment for VOC analysis was installed during the visit. A complete list of laboratory equipment can be found in appendix G.

Method development **can** be done with the use of existing equipment but there is not enough space in the laboratory for installation of new instruments. The present building does not satisfy the needs for space, ventilation, temperature control or air quality (dust contamination problems).

Method descriptions exist for the analysis methods in use but there are no procedures for other laboratory activities. There is no procedure for checking the water quality or the chemicals. The laboratory balance is not checked or calibrated and the pH meter is only sporadically calibrated. The atomic absorption instrument is calibrated each time a series of samples are analyzed (multilevel and blanks). Field blanks are always analyzed for all SO₂ stations. Control samples are not in use for any of the methods.

All readings and analysis results from the SO₂-method are written down in a notebook. Analysis results and calibration data from the atomic absorption method are stored digitally in EXCEL worksheets.

6.1.2 Selebi Phikwe

The laboratory in Selebi Phikwe is in a separate building that should be sufficient to cover all needs for the present chemical analysis activities in Selebi Phikwe. Only one analysis method is in use (SO₂ by bubbler bottles, pH-titration). The analysis procedure is the same as in Gaborone. Water is purified by distillation but not checked. Chemicals are not checked. There is a refrigerator in the laboratory but the H₂O₂ is stored in a cupboard with no temperature control. The same chemicals are used both in Selebi Phikwe and Gaborone. The laboratory balance is not checked or calibrated and the pH meter is only sporadically calibrated. Field blanks are always analyzed for all SO₂ stations. Control samples are not in use. All readings and analysis results from the SO₂-method are written in a notebook in the same way as in Gaborone.

A complete list of laboratory equipment can be found in appendix G.

6.2 Type of equipment needed

The need for equipment in the laboratory is dependent of the activities that should be carried out in the laboratory at the end of the three years of the project. A tentative list of measurement programme parameters has been made by the Department of Mines (appendix H). This list will be the basis for an evaluation of the needs.

The present laboratory situation gives no room for any significant extension of the activities. Most of the equipment will not be purchased until the new laboratory is finished. A detailed list of equipment to be purchased can not be made until the needs are evaluated in detail and discussed with experts in different fields.

A tentative list could look like this:

- Ion chromatograph
- High performance liquid chromatograph
- Gas chromatograph (FID/ECD)
- Equipment for thermodesorption of adsorption tubes on GC
- Equipment for handling of a wide range of organic sample matrices
- High performance laboratory balances
- Water purification system (higher capacity)
- Instruments for measurement of conductivity (precipitation samples and control of water quality)
- X-ray diffraction spectrometer
- Automatic titrator

6.3 QA/QC workshop

A system for Quality assurance and quality control (QA/QC) is essential to run a modern labororium for chemical analysis.

A QA/QC-system was presented and discussed as part of the workshop at the chemical laboratory in Gaborone. The discussion is summarized in Appendix I. Appendix I will be used as a basis for establishing a QA/QC-system at the chemical laboratory.

More detailed guidelines for a complete QA/QC-system will be designed and presented at the next workshop in Gaborone.

6.4 Planning of a new laboratory

Department of Mines plan to build a new laboratory to fulfil future needs within the air quality monitoring and surveillance program. A workshop at the chemical laboratory was held to investigate the space requirements. The discussion is summarized in Appendix J including sketches of possible laboratory facilities to cover these needs.

The sketches indicated roughly a space requirement for the chemical laboratory of about 350 m². A rough estimate of the manpower needed to run such a laboratory

could be 7 to 10 chemists, in addition to 6 to 10 laboratory assistants, a total of 15 to 20 persons. Personnel for administrative work is not included.

7. Training assessment

The training of DoM personnel can be divided into two groups:

- training of DoM personnel in Botswana,
- training of DoM personnel in Norway.

The training can be divided into three topics:

- Maintenance, calibration and treatment of data from the monitors.
- On-the-job training at NILU's chemical laboratories to get an overview of how a modern chemical laboratory is run.
- To understand what causes the impacts measured, use of results from the monitors, chemical analysis and training in use of models.

The different topics covered in this project have different needs of training, and individual persons from DoM have been assigned to the different topics.

Training of DoM personnel in Botswana:

Chemical analysis

A workshop on QA/QC system will be held in Gaborone spring 1997. The workshop will include a development of a QA/QC system for the laboratory in Gaborone. This QA/QC system will have to be revised when the new laboratory is finished and new methods and new procedures are introduced.

On-the-job training at the laboratory will be performed.

Instrumentation

The training in handling of instruments and development of procedures for the monitoring stations will be performed as an on-the-job training because the procedures will be different for the different stations. The procedures at NILU will be used as an example.

Analysis of data and modeling

The training will be conducted as a combination of workshops and on-the-job training. The training will include;

- analysis of measured data
- modeling with single source models for long and short concentration estimates
- use of models and measurements for planning purposes
- consequence analysis of industries
- writing of reports.

Training of DoM personnel at NILU:

Chemical analysis

Personnel from DoM should undertake a long term training program at NILU on procedures on how to run an accredited laboratory. This person will also work at the laboratory with analysis techniques applicable to his/her work at DoM and which NILU can use later. This person will have to stay at NILU for a minimum of 6 months and the living allowance and expenses must be paid by DoM. NILU will also need to agree on the allowance so that NILU is sure that the person can maintain a minimum standard of living.

The training program can start in spring 1997 (March/April) and will last for approximately 6 months.

The training will contain the following activities:

- General information about NILU and NILU activities.
- General information on how the laboratories are run at NILU
- The QA/QC system at the NILU laboratories
 - * inorganic analysis
 - ◇ sample handling
 - ◇ analysis of air and precipitation by IC
 - ◇ analysis of air and precipitation by photometric methods
 - ◇ analysis by ICP-MS
 - ◇ PM₁₀
 - * organic analysis
 - ◇ sample handling
 - ◇ VOC method development
 - ◇ aldehyds/ketons,HPLC, air/indoor
 - ◇ PAH
 - ◇ pesticides and other persistent organic pollutants (POPs)
- Evaluation of 1. training visit

This training program is planned to end before December 1997.

A second training visit to NILU for DoM personnel is planned for January 1998 and will last for approximately 4-6 months. A third training visit can take place during the last year of the project.

Instrumentation

NILU does not use all the different brands of instruments/monitors that DoM have purchased. This means that personnel from DoM will only have a limited possibility to get a fruitful training at NILU. However, one DoM person should visit NILU for a short period (4-8 weeks) to get an introduction to how the instrument laboratory at NILU works. The training program will contain:

- Calibration of monitors
- Calibration of bubblers
- Repair and maintenance of bubblers, monitors and particle collectors
- QA/QC on the above mentioned equipment
- Inspection of monitoring stations concerning routines, calibration and control
- Data inspection and QA/QC
- Evaluation of further training

This training should take place during the first year of the project.

Analysis of data and modeling

Personnel from DoM also need training in use of air quality data (AQ) and meteorological measurements. This training is planned so that the DoM person in training enters into the workforce at the local department at NILU to participate in normal project work at the department. This training should last for approximately 6 months.

The training will include:

- Modeling
- Analysis of data
- Consequence analysis
- Writing of reports
- Evaluation of training and plans for future training.

This training period will take place when NILU have relevant projects that are suitable for training and should probably be scheduled for the second year of the project.

8. References

Sivertsen, B. (1995) Planning mission in July 1995 to establish a project proposal for NORAD in Botswana. Kjeller (NILU RR 5/95)

Appendix A
Seminar program



Air quality Monitoring Programme for Botswana Seminar and workshop programme

Seminar at the President hotel, Gaborone

Monday 4 November 1996

- 0900 Welcome address and opening of the seminar
 0915 Presentation of participating institutes
 Norwegian Institute for Air Research (NILU)
 Environmental Institutes of Norway
 Department of Mines Botswana
 Environmental Council of Zambia
 0945 The modern air pollution monitoring and surveillance programmes
 1030 Coffee
 1100 The complete monitoring system (AirQUIS):
 sensors - data transfer - data control -data bases -statistical and
 numerical models - geographical information systems - user
 friendly presentations)
 1300 Lunch
 1400 AirQUIS (continued)
 1600 Questions ,exercises
 1700 End

Tuesday 5 November 1996

- 0900 The monitoring programme:
 Siting and siting studies
 1030 Coffee
 1100 Air Quality Indicators, Air Quality Guidelines and Standards
 1130 Instruments (samplers - monitors for air quality and meteorology)
 Data transfer
 Quality assurance
 1300 Lunch
 1400 Sampling procedures and chemical analyses
 1530 Data presentation ,
 statistical programmes
 1630 Questions

Wednesday 6 November 1996

- 0900 Meteorology:
the importance and use of meteorological data;
introduction to transport, turbulence and diffusion
- 1030 Coffee
- 1100 Air pollution modelling
emission modelling
emission data bases
- 1200 Different type of models (single source, industrial complexes,
multiple source, advanced numerical models)
- 1300 Lunch
- 1400 Model application
Monitoring network design using models.
- 1630 Questions

Thursday 7 November 1996

- 0900 Data evaluation and presentation
Data transfer and data bases
Air quality data interpretation,
Use of meteorological data
- 1030 Coffee
- 1100 Statistical programmes
- 1200 User friendly presentations
The use of GIS
- 1300 Lunch
Environmental impact of air pollution
Trend analyses
- 1500 Revision and control of air pollution control strategies

Friday 8 November 1996

- 0900 The content of the annual report (Typical examples)
Impact assessments
Consequence analyses
Control strategies
- 1030 Coffee
- 1100 Summary, questions, comments
- 1330 Finalizing the seminar
Lunch

Appendix B

Opening speech by the Honourable Minister of Mineral Resources and Water Affairs

MINISTRY OF MINERAL RESOURCES AND
WATER AFFAIRS

DEPARTMENT OF MINES

OPENING SPEECH FOR A TRAINING SEMINAR
ON
AIR QUALITY MONITORING PROGRAMME
FOR
BOTSWANA

By

The Honourable Minister of Mineral Resources
and Water Affairs

The President Hotel, Gaborone.

Monday, November 4, 1996.

**OPENING SPEECH FOR TRAINING SEMINAR
ON
AIR QUALITY MONITORING PROGRAMME FOR
BOTSWANA**

Ladies and gentlemen, it gives me great pleasure to welcome you all to this very important seminar which will address among other things air pollution dispersion modeling. In a special way, I would like to welcome the team of Norwegian scientists from the Norwegian Institute for Air Research. They have come here to share with our professionals and technicians, their experiences and expertise in preventing and solving air pollution problems. I have been informed that the Institution has given us some of the best scientists they have in the area of air pollution research. I am therefore confident that this training seminar will be a great success. I hope that during their stay in Botswana they will also have the opportunity to learn something about our country.

Mr. Chairman, Botswana and Norway have a long standing cordial relationship. In May 1985 the two countries entered into an agreement focusing on cooperation for Promotion of the Economic and Social Development of the Republic of Botswana. That agreement was extended by an addendum in March 1990. It was on the basis of this main agreement that a specific agreement on Assistance to Air Pollution Monitoring and Surveillance System was reached by the two governments.

Mr. Chairman, ^{the present} this agreement is ^{therefore} a reflection of a mutual commitment by the two countries to curtail the effects of environmental pollution and promote the concept of sustainable development in Botswana. That is, to ensure that our economic development efforts meet the needs of the present generation without compromising the ability of the future generations to meet their own needs. The driving forces

behind undertaking such a programme are numerous. There is mounting scientific evidence that pollution can have local, regional and global consequences. Our vulnerable environment in Botswana with its limited natural resources constitute some of the major driving forces for better pollution control in the country. In addition Botswana recognises herself as a member of the world community. Therefore, as a nation we need to play our role in addressing some of these environmental issues which threaten the very existence of man.^{kind} These represent challenges for us to develop and implement a reliable and effective pollution monitoring and control management system for the country. Our need to diversify the economy of the country from heavy dependence on the mineral sector to manufacturing industry requires us to take stock of our environmental performance and establish objectives and targets which will ensure that we do not depart from the

pursuit of sustainable development. We therefore need to take a snap-shot of the current setting so that we can define the path of our progress. Perhaps the best way to do this is through legislative framework. I will confine myself to air pollution legislation but you should bear in mind that pollution does not respect media boundaries. We know that what goes up in smoke stacks comes down with rain and pollutes our surface water resources.

Mr. Chairman, the Government of Botswana promulgated the Atmospheric Pollution (Prevention) Act in 1971. The act defines the powers and functions of the Air Pollution Control Officer and sets out procedures for the issue of registration certificates to all persons or companies operating industrial processes involving the emission of objectionable matter to the atmosphere in designated controlled areas. The regulation of

air pollution and requirements for installation and operation of air pollution monitoring and abatement facilities is thus effected by the Air Pollution Control Officer through conditions set forth in the registration certificate for each individual industrial process. A procedure for appeals from decisions of the Air Pollution Control Officer and penalties for conviction of an offence under the act are set out in the legislation.

The Atmospheric Pollution (Prevention) Act is administered under the direction of the Ministry of Mineral Resources and Water Affairs through the Department of Mines. The department has established thirteen air pollution monitoring stations throughout the country. Six of these stations are equipped with automatic instruments that give hourly average concentrations of pollutants and other parameters. There are

two laboratory facilities; one in Gaborone and the other in Selebi-Phikwe. The laboratory in Gaborone is ^{unfortunately} congested and over-crowded and needs upgrading.

Mr. Chairman, it is from this situation and position that we would like the Norwegians to help us move forward and this programme has been established for this purpose. The ultimate goal of the programme is to prevent the pollution of the atmosphere by industries and other anthropogenic activities. The specific objectives are to:

- establish a sound specific basis for policy development
- determine compliance with statutory criteria
- assess eco-system and population exposure
- establish a base for public environmental information and awareness
- identify pollution sources and risks

- **evaluate long-term trends; and**
- **establish a basis for abatement strategy planning.**

These objectives provide a comprehensive and systematic approach to the problem. They sharpen the focus as we press forward towards better environmental performance. One of our policy goals in the mineral sector is safeguarding the environment. The objective of the policy is to ensure that Botswana's practices are consistent with international standards and the National Conservation Strategy goal. To fulfill the specific policy, the following three prerequisites have to be considered.

- 1. an air pollution monitoring and surveillance system;**
- 2. national environmental laboratory**

3. training programme for Batswana experts at the Department of Mines' Air Pollution Control Division so that the Division can operate at a higher level of efficiency, internationally comparable to other organisations of similar nature.

Mr. Chairman, let me elaborate on these three pre-requisites for achieving our objectives. We know that there are different sources of anthropogenic activities that emit various contaminants into the atmosphere, especially in the urban and industrial areas. If the concentrations of these pollutants are left to increase beyond certain levels, they could cause human health problems and also have negative impacts on the environment. We also know that our development activities may add more pollution into the atmosphere. The proposed air pollution monitoring and surveillance system will be able to

show us the limits within which to operate so that we do not over-load the overall environment. This means that we constantly need to monitor certain key environmental indicators of pollution to determine if our hypothesis is correct.

Mr. Chairman, this leads me now to briefly discuss the need for a national environmental laboratory. Air pollution affects biological as well as non-biological systems. It is within these systems that indicators can be selected and tested in a laboratory to determine any evidence of impacts. The laboratory should use techniques that are sensitive enough to give warning signs rather than show a problem that has already developed. This requires accurate analytical methods using reliable and sensitive laboratory facilities. The government of Botswana is committed to establishing a National Environmental Laboratory in Gaborone. This will be

a replacement of the one at the Department of Mines' offices in Tirelo House, which is over-crowded and potentially unsafe. Some analysis cannot be carried out at the present environmental laboratory at the Department of Mines because the building was not originally designed to house a laboratory.

Mr. Chairman, so far I have been talking about programmes and facilities that will enable us to fulfill our objectives and realise our goal. I now need to address myself to the human resources that would be required to implement these programmes and run the facilities. If we do not address the aspect of human resources development we would have missed out an opportunity to implement one of Botswana's four national principles, self-reliance. But what does self-reliance mean in the context of this programme? How can it be achieved or realised?

Mr. Chairman, Batswana believe that as a nation we must take the initiative and responsibility for running the affairs of our own country with minimum assistance from other countries. We owe it to the Norwegian government and the people of Norway that at the end of this agreement period we should be able to run these programme and facilities on our own. The generosity of the Norwegian government, in making this programme possible makes it necessary for us to make this programme sustainable. But this cannot be accomplished without a comprehensive training programme that has clear objectives. I have been informed that Norway has some of the best technical experience and expertise in air pollution monitoring and control in the world. I therefore hope that this training seminar is only the beginning of a concerted effort in human resources development and capacity building.

Mr. Chairman, at the beginning of my speech I mentioned that we are carrying out this exercise in pursuit of sustainable development. I would like to point out that the World Commission on Environment and Development states that

“sustainable development is not a fixed state of harmony, but rather a process of change in which the exploitation of resources, the direction of investments, the orientation of technological development, and institutional change are made consistent with future as well as present needs.”

I interpret this to mean that we are constantly in a learning process. As we acquire knowledge we need to adjust our objectives in the light of what we know so that we will continue in the path of sustainable development.

Mr. Chairman, indeed the history of mankind has been like that. When man started knowing how to light and use fire his main concern was to eliminate smoke and other pollutants known to have adverse effects on human health. The ideal and desired situation was to burn the fuel completely so that carbon dioxide and water vapour were the only products of combustion. But we now know that carbon dioxide is one of the major potential threats to life as we know it on this planet. The United Nations Framework Convention on Climate Change is aimed at addressing this problem.

In the early 1920s the addition of lead to petrol was viewed with great enthusiasm. It improved the octane rating and therefore reducing refinery costs of petrol. But we now know that lead emissions from motor vehicles constitute a serious

health threat especially to our children. We now have to phase out leaded petrol in order to clean up our atmosphere.

In the sixties and seventies we thought that the solution to pollution was dilution. We built tall stacks so that our industrial emissions could be released at high altitude and allow them to disperse into the atmosphere so that when they reach ground level they will be diluted to lower concentrations. We now know that this approach is partly responsible for acid rain in many parts of the world. We have since realized that eliminating the production of sulphur and nitrogen oxides from stack gases is a much better way to deal with this problem.

Mr. Chairman this state of affairs should present a challenge to our scientists and engineers. The Science and Technology

Policy for Botswana which is being developed will create a conducive environment for our scientists and engineers to compete and interact with the rest of the world.

Finally ladies and gentlemen I wish to end my speech on this note; that the natural resources of this country, or indeed this planet, are not unlimited, and this includes the quality of air that we breathe, and it is our collective responsibility to safeguard our environment and natural resources. Let us use them in a sustainable manner. I now have pleasure in declaring this seminar officially open.

PULA!

Appendix C

List of participant and people we met

**SEMINAR ON AIR QUALITY MONITORING PROGRAMME FOR BOTSWANA
(4 - 8 November, 1996)**

LIST OF PARTICIPANTS

Bjarne Sivertson
Norwegian Institute for Air Research (NILU)
Instituttveien 18
P.O. Box 100
N-2007 Kjeller
Norway.

Tel. 00-47-63 89 80 00

Fax. 00-47-63 89 80 50

E-mail. bjarne.sivertson@nilu.no

Rolf Dreiem
Norwegian Institute for Air Research (NILU)
Instituttveien 18
P.O. Box 100
N-2007 Kjeller
Norway.

Tel. 00-47-63 89 80 00

Fax. 00-47-63 89 80 50

E-mail. Rolf.@nilu.no

Tone Bekkestad
Norwegian Institute for Air Research (NILU)
Instituttveien 18
P.O. Box 100
N-2007 Kjeller
Norway.

Tel. 00-47-63 89 80 00

00-47-63 89 80 87 (Direct)

Fax. 00-47-63 89 80 50

E-mail. tone@nilu.no

Choma J. Matala
Department Of Mines
Private Bag 0049
Gaborone,
Botswana.

Tel. 267-352641

Fax. 267-352141

Svein L. Knudsen
Norwegian Institute for Air Research (NILU)
Instituttveien 18
P.O. Box 100
N-2007 Kjeller
Norway.

Tel. 00-47-63 89 80 00

Fax. 00-47-63 89 80 50

E-mail. sofus@nilu.no

Tiroyaone Tshukudu
Department Of Mines
Private Bag 0049
Gaborone,
Botswana.

Tel. 267-352641

Fax. 267-352141

Ove Hermansen
Norwegian Institute for Air Research (NILU)
Instituttveien 18
P.O. Box 100
N-2007 Kjeller
Norway.

Tel. 00-47-63 89 80 00

00-47-63 89 82 16 (Direct)

Fax. 00-47-63 89 80 50

E-mail. ove.hermansen@nilu.no

Kabelo Kenneth Mogami
Department Of Mines
Private Bag 0049
Gaborone,
Botswana.

Tel. 267-352641

Fax. 267-352141

Kene Carol Lenyatso
Department Of Mines
Private Bag 0049
Gaborone,
Botswana.

Tel. 267-352641

Fax. 267-352141

Moabi Donald Mmolawa
 Department Of Mines
 Private Bag 0049
 Gaborone,
 Botswana.

Tel. 267-352641

Fax. 267-352141

Oarabile Moanza Serumola
 Department of Water Affairs
 Private Bag 0029
 Gaborone
 Botswana

Tel. 267-3607173

Fax. 267-303508

Selogilwe Mokubukubu Mosinyi
 Department Of Mines
 Private Bag 0049
 Gaborone,
 Botswana.

Tel. 267-352641

Fax. 267-352141

Lesego Modisane
 BCL Ltd
 P.O. Box 3
 Selebi-Phikwe
 Botswana

Tel. 267-810211 (extension 375)

Fax. 267-810441

Gorata Lesedi Motshwane
 Department Of Mines
 Private Bag 0049
 Gaborone,
 Botswana.

Tel. 267-352641

Fax. 267-352141

Hentie J.P. Hough
 Ministry of Mines & Energy
 Private Bag 13297
 Windhoek
 Namibia

Tel. 2484300

Fax. 238643

Supervisor Mothusi Sreetsi
 Department of Mines
 Private Bag 0027
 Selebi Phikwe
 Botswana

Tel. 267-810680

Fax. 267-810680

*At the meteorological
 office at the airport in
 Francistown we met:*

*Mr. G.G. Mbaiwa
 Chief Technical Assistant*

Albert Mukuwa
 Department of Mines
 Private Bag 0027
 Selebi Phikwe
 Botswana

Tel. 267-810680

Fax. 267-810680

*Ms. Patricia G. Mbitiwa
 Technical Assistant*



DEPARTMENT OF MINES
PRIVATE BAG 0049
GABORONE
BOTSWANA

Ribson C. Gabonowe
(BSC, M.S.)
CHIEF GOV. MINING ENGINEER

TEL: (267) 352142
TELEX: 2503 BD
FAX: (267) 352141



DEPARTMENT OF MINES
PRIVATE BAG 0049
GABORONE
BOTSWANA

Choma J. Matala
B.ENG. (HON) FUEL & ENERGY ENGINEERING
(LEEDS U.K.) MSc. ENVIRONMENTAL
POLLUTION CONTROL (LEEDS U.K.)
PRINCIPAL AIR QUALITY INSPECTOR

TEL: (267) 352641
TELEX: 2503 BD
FAX: (267) 352141

M.D. Mmolawa OTD (Electrical & Mechanical Engineering,
Botswana Polytechnic

SENIOR TECHNICAL OFFICER
Air Pollution Control Division
Department of Mines

MINISTRY OF MINERAL RESOURCES AND WATER AFFAIRS

PRIVATE BAG 0049
GABORONE
BOTSWANA

TEL: (267) 352641 (W)
FAX: (267) 352141

K.C. Lenyatso Bsc (Chemistry), Univ. of Botswana

ASSISTANT CHEMIST
Air Pollution Control Division
Department of Mines

MINISTRY OF MINERAL RESOURCES AND WATER AFFAIRS

PRIVATE BAG 0049
GABORONE
BOTSWANA

TEL: (267) 352641 (W)
FAX: (267) 352141

T. Tshukudu Bsc. (Chemical Engineering), Kansas State University

ASSISTANT GOVERNMENT MINING ENGINEER
Air Pollution Control Division
Department of Mines

MINISTRY OF MINERAL RESOURCES AND WATER AFFAIRS

PRIVATE BAG 0049
GABORONE
BOTSWANA

TEL: (267) 352641 (W)
FAX: (267) 352141

K.K. MOGAMI Bsc. (Physics & Chemistry), Univ. of Botswana

ASSISTANT CHEMIST
Air Pollution Control Division
Department of Mines

MINISTRY OF MINERAL RESOURCES AND WATER AFFAIRS

PRIVATE BAG 0049
GABORONE
BOTSWANA

TEL: (267) 352641 (W)
FAX: (267) 352141



Mrs O.M. Serumola BSc (Hons) Environmental and Chemical Sciences • MSc/EST

ENVIRONMENTAL SCIENTIST (POLLUTION SECTION)
DEPARTMENT OF WATER AFFAIRS
MINISTRY OF MINERAL RESOURCES AND WATER AFFAIRS

PRIVATE BAG 0029
GABORONE
BOTSWANA

TELEX 2557 BD
TEL. (09267) 3607173 Bus.
TELEFAX (267) 303508



Laurence G. Mosweunyane
BSc (Hons) FRSH
ENVIRONMENTAL ENGINEER

P.O. Box 3
Selebi Phikwe
Republic of Botswana
Tel: 810211 ext 260
Telex Site 2219 BD
Fax: 810441

Private Bag X 10055
Randburg 2125
Republic of South Africa
Tel: (011) 781-2352
Fax: (011) 781-2364

Oskar Oskarsen

~~*Britt Hilde Kjoelaas*~~

~~FIRST SECRETARY~~
CHARGE D'AFFAIRES A.I.

ROYAL NORWEGIAN EMBASSY

Development House
Postal Address:
P.O. Box 879
Gaborone, Botswana

Telephone: (267) 351501
Telefax: (267) 374685
Home/Fax: (267) 371092

Britt Hilde Kjoelaas

FIRST SECRETARY

ROYAL NORWEGIAN EMBASSY

Development House
Postal Address:
P.O. Box 879
Gaborone, Botswana

Telephone: (267) 351501
Telefax: (267) 374685
Home/Fax: (267) 371092

Appendix D

Reports from seminar i national newspapers

DAILY NEWS

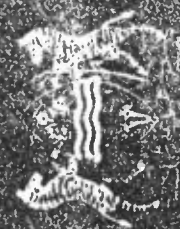

Republic of Botswana

The paper that informs and educates

Monday

November 11, 1996

No. 213

Agreement paves way for aid

By **Leloba Seitshiro**

Botswana and Norway have signed an agreement that will pave way for Norwegian financial assistance to the Air Pollution Monitoring and Surveillance Programme in Botswana.

Mr Oskar Oskarsson, Norwegian Ambassador to Botswana, said when closing an Air Pollution Monitoring Seminar at Presi-

dent Hotel last week that the agreement is an example of Norwegian development cooperation with Botswana.

Also, he explained that "the projects and programmes we now agree to finance in Botswana are based on cost sharing between our two countries.

The words of cooperation and co-financing are the correct words to use."

Mr Oskarsson said that in line with this policy the government of Botswana will support the programme by building a new laboratory in Gaborone.

He said that the institutional co-operation between Botswana and Norway will ensure that a broad range of skills and knowledge are transferred and experience is exchanged in an organised way. **OPA**

BOTSWANA DAILY NEWS NOVEMBER 5, 1996 No. 209 PAGE 2

NATIONAL NEWS



The Minister of Mineral Resources and Water Affairs, Mr David Magang (centre) officiating at a five-day workshop for Air Quality Monitoring Programme for Botswana which is hosted by the Department of Mines at President Hotel. The minister is flanked by the Director of Mines, Mr Ribson Gabonowe (right) and the Principal Quality Inspector, Mr Choma Matala. Picture: Thompson Keobaletswe

Appendix E

**Meeting between DoM, NILU and NORAD
14 November 1996**

To : OEH, PB, StL
 Copy : NORAD v/ Brit Hilde Kjølås
 From : TOB
 Date : Kjeller, 10 December 1996
 Ref. : O-96082

Meeting between DoM, NILU and NORAD 14 November 1996 at the Royal Norwegian Embassy in Gabarone, Botswana.

Norad had called for a meeting with DoM (Department of Mines) and NILU (Norwegian Institute for Air Research) to discuss;

- present status of the BAQMAP - project,
- what type of information should be copied to NORAD, and
- a date for the annual meeting between NORAD and DoM

Persons attending the meeting:

1. Ms. Brit Hilde Kjølås (NORAD/ 1. secretary at the Norwegian Embassy)
2. Mr. Choma J.Matale (Department of Mines (DoM))
3. Ms. Tone Bekkestad (NILU)

- Present status of the project was summarised by Mr C.J. Matale and Ms T. Bekkestad. The visit by NILU has after the seminar of the first week consisted of a screening study of all the monitoring stations owned by DoM and BCL Limited in Selebi Phikwe. The third week of the visit, NILU and DoM will put up a working plan for at least the next year.

Ms B.H. Kjølås stressed the importance of including expenditures by DoM (i.e. to buy instruments) in the budget for the next year. She also stressed that this is a co-operation between DoM and NILU and that the annual reports and plans should be sent as a draft copy to DoM for acknowledgement. Mr C.J. Matale also explained to Ms B.H. Kjølås that he has now, after the initiation of the project, fully understood the need of practical training of his experts in order to achieve the main goal for the project; to be sustainable after the end of the three-year contract. Mr C.J. Matale stressed that he would like as much resources as possible of the project money be set aside for the on-the-job training of the DoM personnel.

- Ms B.H. Kjølås pinpointed the necessity of sending a copy of all correspondence between DoM and NILU to NORAD.
- According to the signed contract between DoM and NORAD there shall be an annual meeting between the two parties in November each year. However, since the start-up of the project was a bit delayed, this meeting will have to be in January 1997. (The date has been set to 29. or 31. of January 1997. The date will be confirmed by Mr C.J. Matale)

Appendix F

Site visit reports.

Air quality sampling stations in Botswana

Air quality monitoring network Site visit report

- Site Name** : DoM laboratory in Selebi Phikwe
Co-ordinates : S: 21°57'53s E: 27°50'16s UTM:355865 (x) - 3575709 (y)
- Access/availability** : Easy. Parking outside DoM laboratory. Fenced.
- Buildings and rooms available:** DoM facilities.
- Area description** : Residential area. Some trees around. Telephone mast 150 new degrees. The BCL smelter is approximately 3.5 km NE (45°).
- Local sources** : Traffic from minor roads. Burning of waste. Industrial area 0,5-1 km west.
- Representativity** : Suburban/residential. Can measure downwind concentrations from BCL smelter.
- Parameters measured** : None.
- Data quality** : -
- Measurement equipment** : 2 data loggers and 2 SO₂ monitors (API and TE).
- Infrastructure:**
- Power** : 220 V available at DoM laboratory.
 - Telephone lines** : Yes, in DoM laboratory.
 - Sampler/monitor locations:** In laboratory.
 - Air intake** : -
- Personnel** : Mr. A. M. Mukuwa (DoM) and Mr. S. M. Sereetsi.
- Other** : PC equipment: TWM LR 4G (screen), Mecer 6000 (hard disk), Samsung Syncmaster 3 (screen), Compaq ProLinea 3/25S (hard disk), HP LazerJet 4L (printer).
 Have fax modem in laboratory. Measurement data are sent to Gaborone once per month.
- Future monitoring station** : The site is not downwind in the main wind direction from the BCL-smelter. The population of Selebi Phikwe is in general located in the least frequent wind direction, this means south-west of the BCL stack. The site is well located to measure the SO₂ impact from BCL on the population of Selebi Phikwe, but not the maximum impact. The site is also representative for residential areas and could measure NO_x, PM₁₀ in addition to SO₂.

Air quality monitoring network Site visit report

Site Name : DoM laboratory in Selebi Phikwe

Co-ordinates : S: 21°57'53s E: 27°50'16s UTM:355865 (x) - 3575709 (y)

Sampler
location

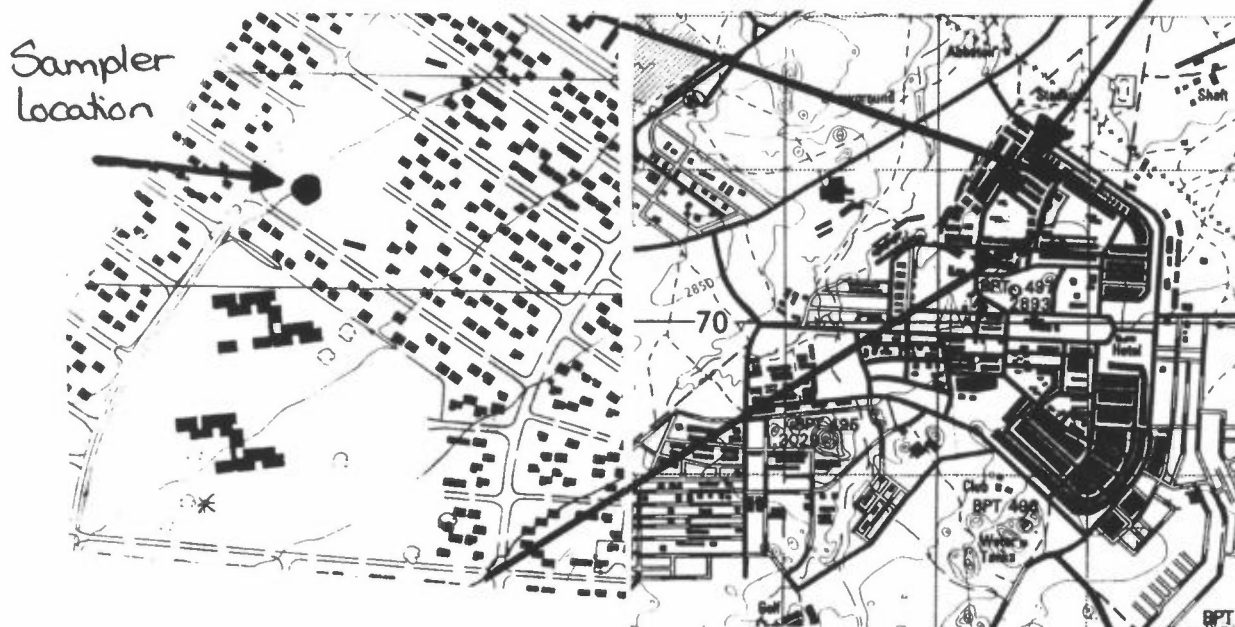

Air quality monitoring network Site visit report

Site Name : DoM laboratory in Selebi Phikwe
Co-ordinates : S: 21°57'53s E: 27°50'16s UTM:355865 (x) - 3575709 (y)





Meteorological tower. Not in operation

Computer equipment at laboratory



Meteorological tower



Air quality monitoring network Site visit report

Site Name	: Botshabelo (Police station)
Co-ordinates	: S: 21°58'23s E: 27°52'18s UTM: 355899(x) - 3575702(y)
Access/availability	: Easy access. Parking outside police station. Fenced. Need permission to get through gate.
Buildings and rooms available:	Sampler located in a small elevated wooden box close to bulding walls (ca. 1 m). Space enough to put up a shelter. (Not likely that any rooms inside police station may be used.)
Area description	: Residential area. 20 m from road. Sandy ground. The BCL smelter is approximatly 3.4 km NNW (340°) of the station.
Local sources	: BCL ~3.4 km NNW. Some emissions from local burning of waste.
Representativity	: The site is representative for the influence from the BCL.
Parameters measured	: SO₂.
Data quality	: The maintenance of the instrument was generally poor.
Measurement equipment	: Old type sequential sampler (bubbler) from AGL Engineering in England (4 bottles) for 24 h average sampling of SO₂.
Infrastructure:	
Power	: 220 V
Telephone lines	: Possible through/via police station (?).
Sampler/monitor locations:	1 m above ground level.
Air intake	: 1.5 m above the ground, ca. 1m from building walls on two sides.
Personnel	: Mr. Jo Madumela (BCL smelter) is responsible for the collection of the bottles. Analysis are performed at the BCL laboratory.
Future monitoring station	: The site is located in the Botshabelo residential area. It is suitable to monitor the impact from BCL and general residential area. Measurements: SO₂, PM₁₀, NO_x.

Air quality monitoring network Site visit report

Site Name : Botshabelo (Police station)
Co-ordinates : S: 21°58'23s E: 27°52'18s UTM: 355899(x) - 3575702(y)

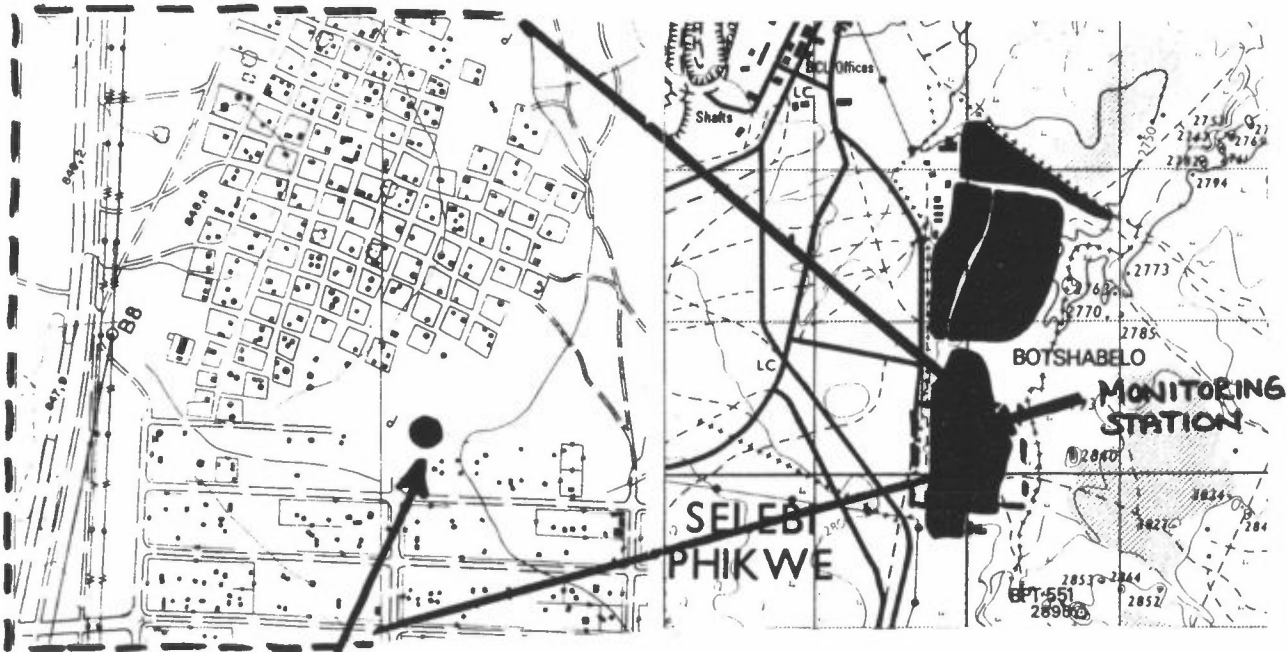

Sampler location

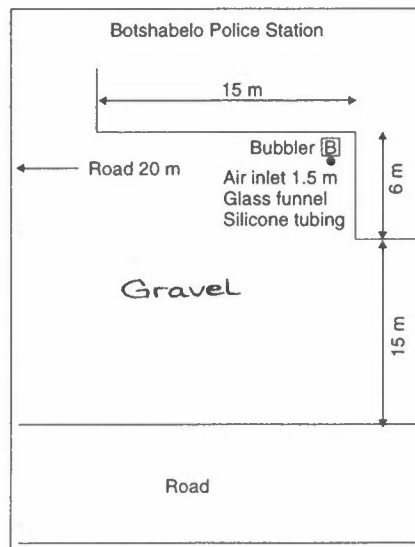

Air quality monitoring network Site visit report

Site Name : Botshabelo (Police station)
Co-ordinates : S: 21°58'23s E: 27°52'18s UTM: 355899(x) - 3575702(y)

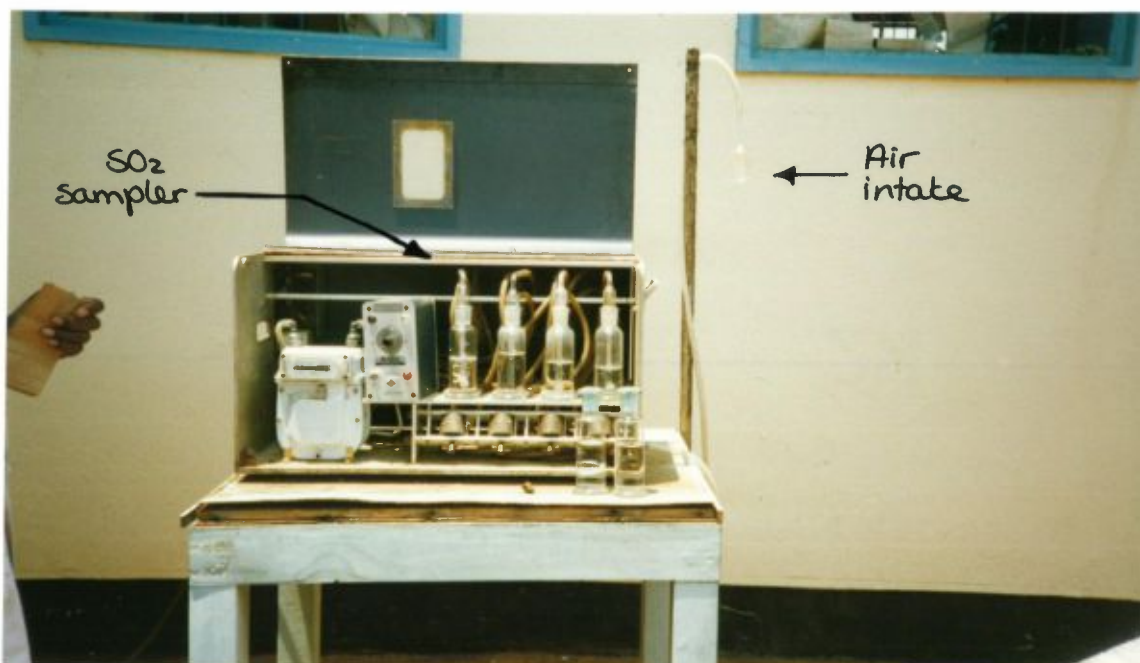

Air quality monitoring network Site visit report

Site Name	: Hospital (306°)
Co-ordinates	: S: 21°58'08s E: 27°50'14s UTM: 355864(x) - 3575706(y)
Access/availability	: Easy access. Parking at hospital properties. Fenced.
Buildings and rooms available:	Sampler located in a small elevated.
Area description	: Residential area. Sandy ground. BCL smelter is located approximatly 3.9 km NE (041°) of the station.
Local sources	: 150 m to incinerator (Hs≈15m). Any impact from hospital??
Representativity	: Residential. Possible impact from BCL stack?
Parameteres measured	: SO₂.
Data quality	: The maintenance of the instrument was genrally poor.
Measurement equipment	: Old type sequential sampler (bubbler) from AGL Engineering in England (4 bottles) for 24 h average sampling of SO₂.
Infrastructure	:
Power	: 220 V
Telephone lines	: No
Sampler/monitor locations:	0.5 m above ground level.
Air intake	: 1.5 m above the ground, approximately 10 m from road.
Personnel	: Mr. Jo Madumela (BCL smelter) is responsible for the collection of the bottles. Analysis are performed at the BCL laboratory.
Future monitoring station	: This site is representative for residential areas in Selebi Phikwe both for emissions from local sources and the BCL emissions, and could measure SO₂, NO_x and PM₁₀.

Air quality monitoring network

Site visit report

Site Name : Hospital (306°)
Co-ordinates : S: 21°58'08s E: 27°50'14s UTM: 355864(x) - 3575706(y)

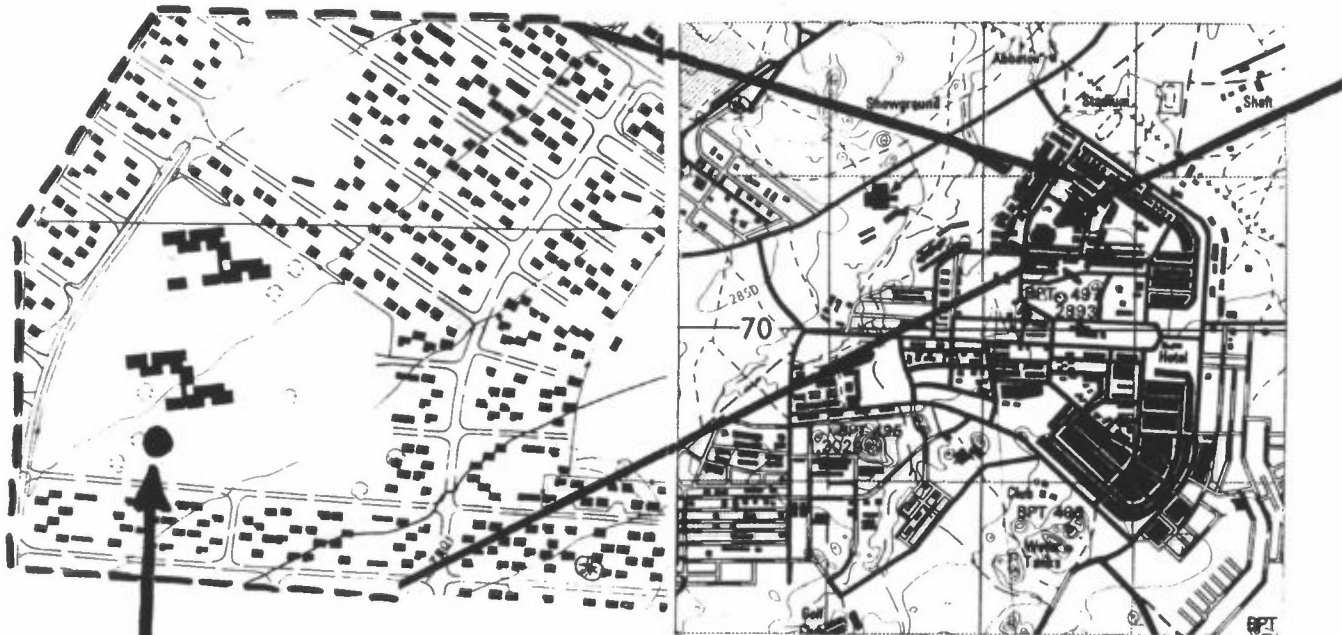

Sampler
Location

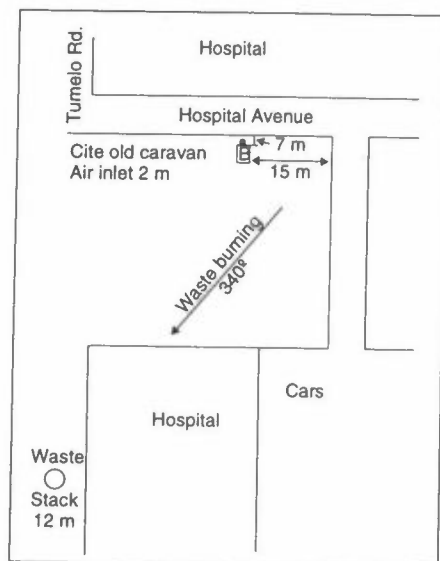

Air quality monitoring network Site visit report

Site Name : Hospital (306°)
Co-ordinates : S: 21°58'08s E: 27°50'14s UTM: 355864(x) - 3575706(y)



Air quality monitoring network Site visit report

Site Name	: BCL Clinic
Co-ordinates	: S: 21°58'10s E: 27°50'28s UTM: 355868(x) - 3575705(y)
Access/availability	: Easy access. Parking along road (Matlogele 1614). Fenced.
Buildings and rooms available:	Sampler located in a small elevated wooden box.
Area description	: Residential area. Sandy ground. Medium densed vegetation close to sampler and air intake. The BCL smelter is approximatly 3.6 km NNE (35°) from the station.
Local sources	: ??
Representativity	: Residential. Possible impact from BCL stack?
Parameteres measured	: SO₂.
Data quality	: The maintenance of the instrument is generally poor.
Measurement equipment	: Old type sequential sampler (bubbler) from AGL Engineering in England (4 bottles) for 24 h average sampling of SO₂.
Infrastructure:	
Power	: 220 V
Telephone lines	: Yes
Sampler/monitor locations:	0.5 m above ground level.
Air intake	: 2.5 m above the ground, on building wall and 2 m under roof, behind hospital.
Personnel	: Mr. Jo Madumela (BCL smelter) is responsible for the collection of the bottles. Analysis are performed at the BCL laboratory.
Future monitoring station	: This site is representative for residential areas in Selebi Phikwe both for emissions from local and the BCL smelter. The measurements could be SO₂, NO_x and PM₁₀.

Air quality monitoring network Site visit report

Site Name : BCL Clinic
Co-ordinates : S: 21°58'10s E: 27°50'28s UTM: 355868(x) - 3575705(y)

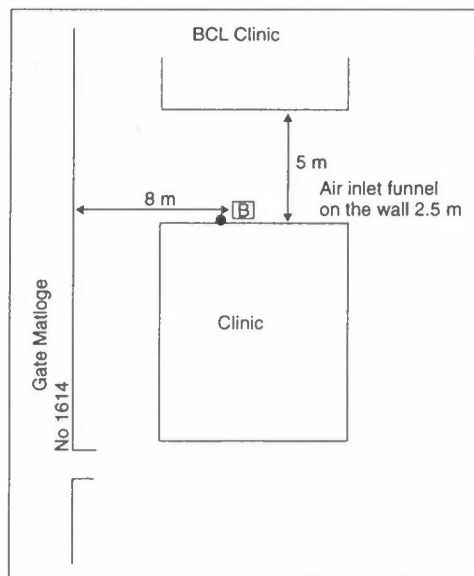
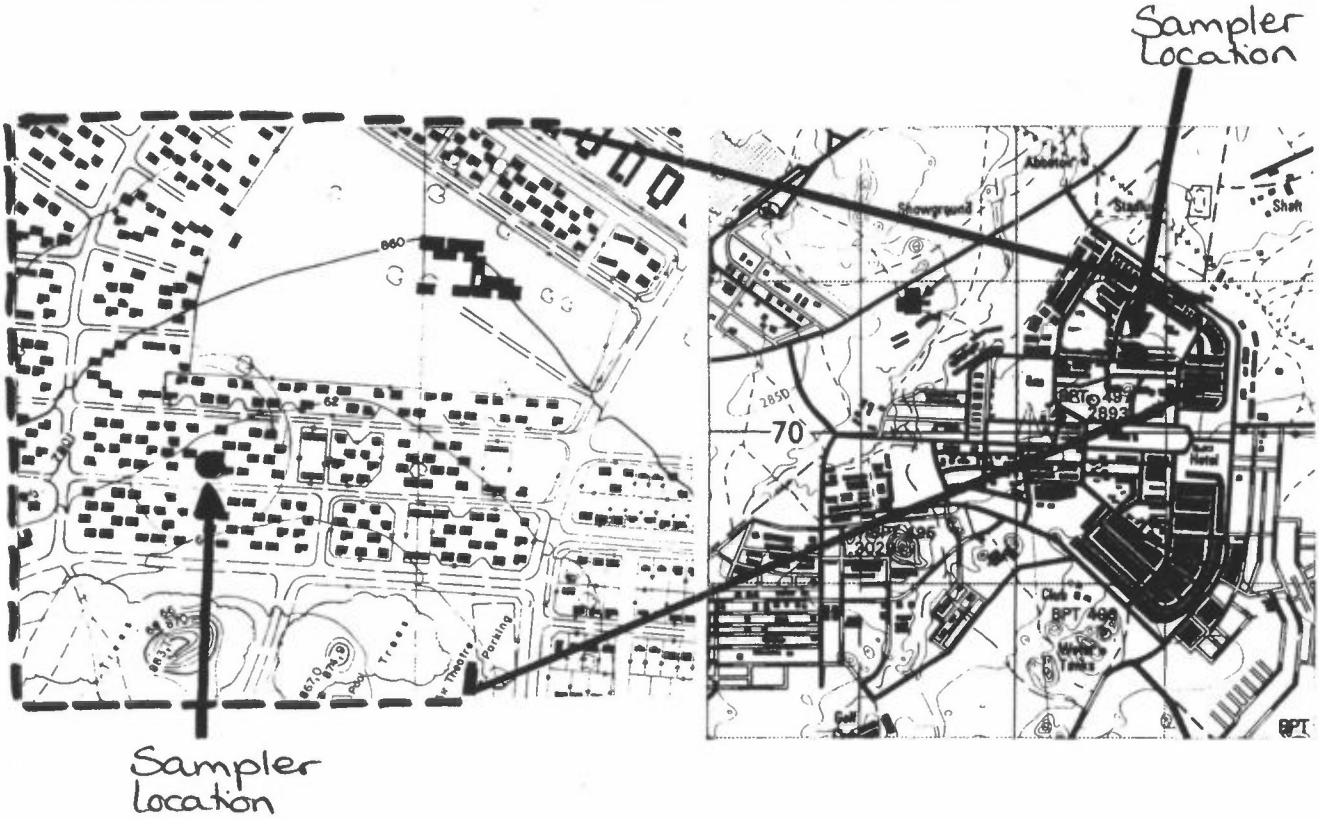

Air quality monitoring network Site visit report

Site Name : BCL Clinic
Co-ordinates : S: 21°58'10s E: 27°50'28s UTM: 355868(x) - 3575705(y)

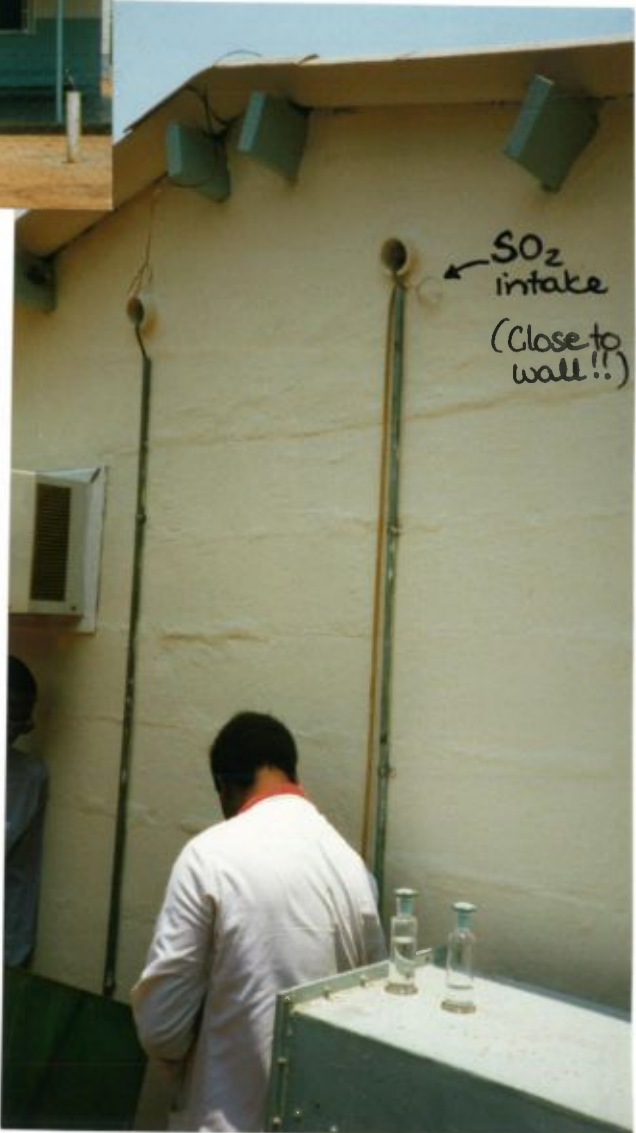

Air quality monitoring network Site visit report

Site Name: Low Density (Kagiso 11043)

Co-ordinates: S: 21°58'50s E: 27°50'42s **UTM: 355872(x) - 3579691(y)**

- Access/availability** : Easy access. Parking along street. Residential property (Kagiso 1103). Inside backyard. Fenced.
- Buildings and rooms available:** Sampler located in a small elevated box inside a 2 m² brick wall in the backyard of residential property. The intake (tube) was stuck in some green plants on top of the brick wall.
- Area description** : Residential area. Approximately 40 m from road road in residential area. Sandy ground. Lots of vegetation and trees around the air intake. The BCL smelter is approximately 4.6 km NNE (022°) of the station.
- Local sources** : No??
- Representativity** : Residential. Possible impact from BCL stack?
- Parameters measured** : SO₂.
- Data quality** : The maintenance of the instrument was generally poor.
- Measurement equipment** : Old type sequential sampler (bubbler) from AGL Engineering in England (4 bottles) for 24 h average sampling of SO₂.
- Infrastructure** :
- Power** : 220 V
 - Telephone lines** : Possible?
 - Sampler/monitor locations** : 0.5 m above ground level.
 - Air intake** : 2 m above the ground stuck in some green plants on top of brick wall.
- Personnel** : Mr. Jo Madumela (BCL smelter) is responsible for the collection of the bottles. Analysis are performed at the BCL laboratory.
- Future monitoring station** : This site is representative for a low density area and also for impacts from the BCL smelter in inhabitant areas. The site could be used to collect SO₂, NO_x, PM₁₀.

Air quality monitoring network Site visit report

Site Name : Low Density (Kagiso 11043)
Co-ordinates : S: 21°58'50s E: 27°50'42s UTM: 355872(x) - 3579691(y)

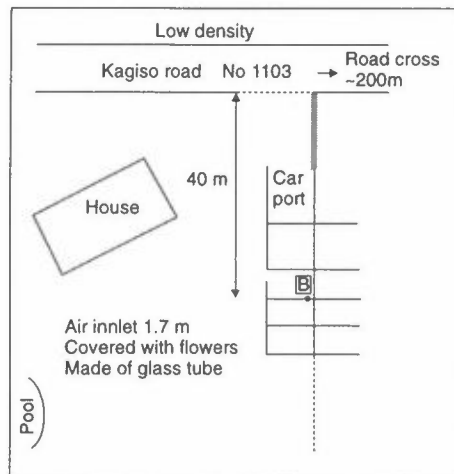

Air quality monitoring network Site visit report

Site Name : Low Density (Kagiso 11043)
Co-ordinates : S: 21°58'50s E: 27°50'42s UTM: 355872(x) - 3579691(y)



Air quality monitoring network Site visit report

- Site Name** : Railway station
Co-ordinates : S: 21°57'41s E: 27°49'04s UTM: 355844(x) - 3575714(y)
- Access/availability** : Easy access. Parking outside. Dead-end road. No fences. Close to railway tracks.
- Buildings and rooms available:** Enough space for a monitoring station. No suitable house nearby.
- Area description** : Sparsely vegetated, fairly open, sandy ground. 20 m from railway tracks. The BCL smelter is approximately 5 km NE (065°) of the station.
- Local sources** : The station is in the main wind direction from the BCL stack. Good siting for registration of impact from the BCL smelter (could smell SO₂). An incinerator approximately 500 m away. Impact from local industry?
- Representativity** : Industrial area. Possible impact from BCL stack?
- Parameters measured** : SO₂, TSP
- Data quality** : The maintenance of the instrument was generally poor.
- Measurement equipment** : Old type sequential sampler (bubbler) from AGL Engineering in England (4 bottles) for 24 h average sampling of SO₂. Sierra (Hi-vol) for measurement of TSP.
- Infrastructure** :
- Power** : 220 V
- Telephone lines** : Possible??
- Sampler/monitor locations** : SO₂: 0.5 m above ground level.
TSP: 2 m above ground level.
- Air intake** : 1 m above the ground (SO₂), on top of the measurement box. Close to old building. Air intake for Andersen is approximately 2 m above ground.
- Personnel** : Mr. A. M. Mukuwa and Mr. S. M. Sereetsi collect the samples for this station and bring them to DoM laboratory in Selebi Phikwe for analysis.
- Future monitoring station** : The site is adequate for measuring SO₂ from the BCL smelter. It is not good for particle measurements because of gravel road close by.

Air quality monitoring network Site visit report

Site Name : **Railway Station**
Co-ordinates : S: 21°57'41s E: 27°49'04s UTM: 355844(x) - 3575714(y)

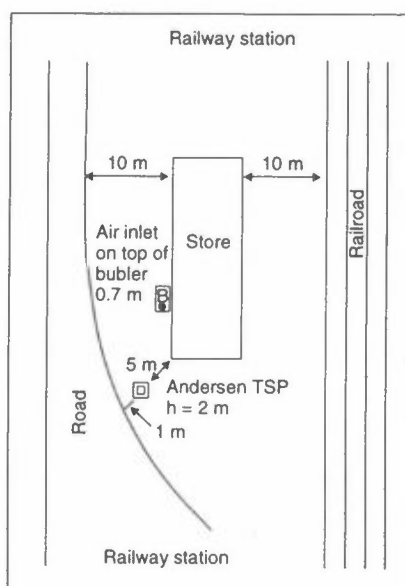
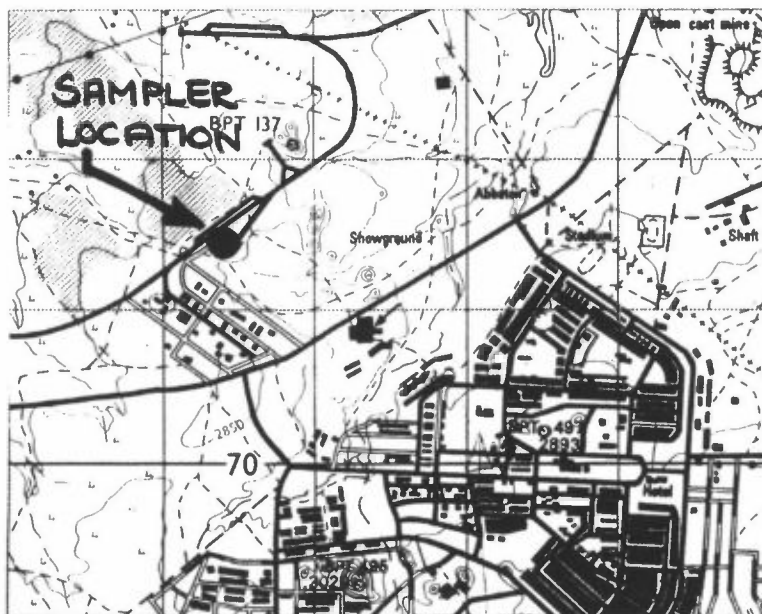

Air quality monitoring network Site visit report

Site Name : Railway
Co-ordinates : S: 21°57'41s E: 27°49'04s UTM: 355844(x) - 3575714(y)



Air quality monitoring network Site visit report

- Site Name** : Railway track
Co-ordinates : S: E: UTM:
- Access/availability** : Access along a sandy bush road across the railway tracks from the monitoring station at the railway. Parking. Dead-end road. No fences. Close to railway tracks.
- Buildings and rooms available:** Enough space for a monitoring station. No houses nearby.
- Area description** : Sparsely vegetated, fairly open, sandy ground. 20 m from railway tracks.
- Local sources** : The station is in the main wind direction approximately 2 km from the BCL stack (95 new degrees west of BCL stack). Good siting for registration of impact from the BCL smelter? Impact from coal fired train passing by only 20 m from sampler.
- Representativity** : Possible impact from BCL stack with some influence from trains?
- Parameters measured** : SO₂.
- Data quality** : The maintenance of the instrument was generally poor.
- Measurement equipment** : Old type sequential sampler (bubbler) from AGL Engineering in England (4 bottles) for 24 h average sampling of SO₂.
- Infrastructure** :
- Power** : Battery. No power. Possible at high cost?
 - Telephone lines** : No. Railway telephone lines 500 m away.
 - Sampler/monitor locations:** 0.7 m above ground level.
 - Air intake** : 1.2 m above the ground, 5 cm out from the "shelter"/box. The air intake is on the lewar side of the measurement box from the railway tracks.
- Personnel** : Mr. A. M. Mukuwa and Mr. S. M. Sereetsi collects the samples for this station and brings them to DoM laboratory in Selebi Phikwe for analysis. The sampler had not been in operation the last week because Mr. Mukuwa and Mr. Sereetsi attended the NILU seminar on Air Pollution Monitoring and its Applications in Gaborone. There is no personnel available to do the sampling if Mr. Mukuwa and Mr. Sereetsi is away.
- Future monitoring station** : The site is good for measuring SO₂ from the BCL smelter and is located south of the main wind direction.

Air quality monitoring network

Site visit report

Site Name : Railway track
Co-ordinates : S: E: UTM:

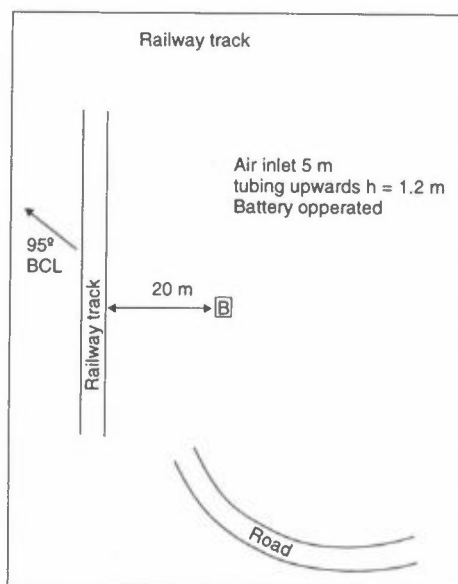
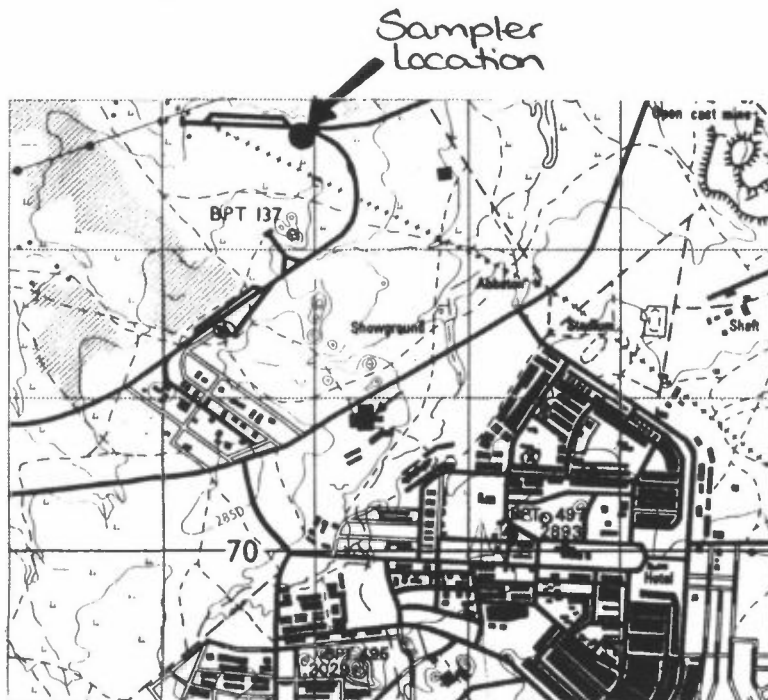

Air quality monitoring network Site visit report

Site Name : Railway track
Co-ordinates : S: E: UTM:



Air quality monitoring network Site visit report

Site Name : SPSS - Selebi Phikwe Secondary School
Co-ordinates : S: E: UTM:

- Access/availability** : Easy access. Parking outside school. Fenced.
- Buildings and rooms available** : Sampler is located in room inside biology/science building at school properties.
- Area description** : Flat, sandy ground, fairly open outside school properties. School buildings around in all directions from air intake.
- Local sources** : The station is in the main wind direction approximately 1.6 km south of the BCL stack. Good siting for registration of impact from the BCL smelter.
- Representativity** : Set up to measure possible impact from BCL stack and other industry.
- Parameters measured** : SO₂.
- Data quality** : The maintenance of the instrument was generally poor.
- Measurement equipment** : Old type sequential sampler (bubbler) from AGL Engineering in England (4 bottles) for 24 h average sampling of SO₂.
- Infrastructure** :
- Power** : 220 V
 - Telephone lines** : Yes
 - Sampler/monitor locations** : On bench, ~0.7 m above floor.
 - Air intake** : 2.5 m above the ground, underneath roof in corner of school building. 3 m tall tree 20 cm from air intake.
- Personnel** : Mr. A. M. Mukuwa and Mr. S. M. Sereetsi collects the samples for this station and brings them to DoM laboratory in Selebi Phikwe for analysis.
- Future monitoring station** : The site could be used for SO₂ bubblers.

Air quality monitoring network Site visit report

Site Name : SPSS - Selebi Phikwe Secondary School
Co-ordinates : S: E: UTM:

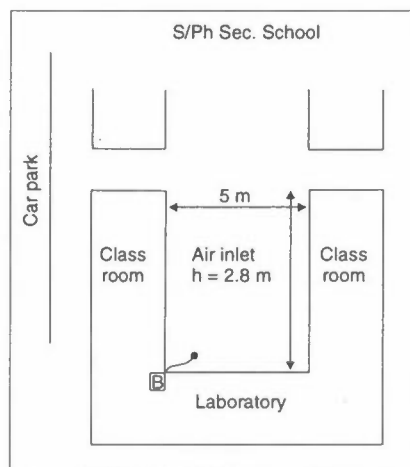

Air quality monitoring network Site visit report

Site Name : SPSS - Selebi Phikwe Secondary School
Co-ordinates: : S: E: UTM:

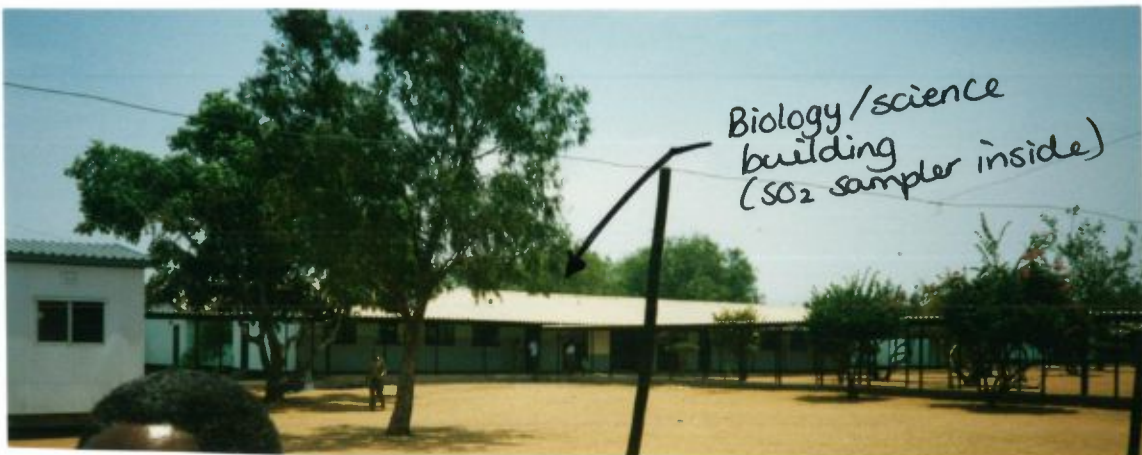

Air quality monitoring network Site visit report

Site Name	: Township West.
Co-ordinates	: S: E: UTM:
Access/availability	: Easy access. Parking along Lapologang road (Lapologang Rd C38). Fenced. In the backyard of residential property.
Buildings and rooms available	: Sampler is located inside residential home, underneight kitchen bench
Area description	: Residential, sandy ground, sparse vegetation with some trees ouside house on property. Minor road approximately 10 m from air intake.
Local sources	: The station is approximately ?? km southeast of the BCL stack. There are some industrial sources north of measurement site.
Representativity	: Residential. Set up to measure possible impact from BCL stack and other industry.
Parameters measured	: SO ₂ .
Data quality	: The maintenance of the instrument was generally poor.
Measurement equipment	: Old type sequential sampler (bubbler) from AGL Engineering in England (4 bottles) for 24 h average sampling of SO ₂ .
Infrastructure	:
Power	: 220 V
Telephone lines	: Yes.
Sampler/monitor locations:	On the floor under kitchen bench.
Air intake	: 1.8 m above the ground, underneath roof, close to building wall. Approximately 20 m from residential road.
Personnel	: Mr. A. M. Mukuwa and Mr. S. M. Sereetsi collects the samples for this station and brings them to DoM laboratory in Selebi Phikwe for analysis.
Future monitoring station	: SO ₂ bubblers could be used here.

Air quality monitoring network Site visit report

Site Name : Township West.
Co-ordinates : S: E: UTM:

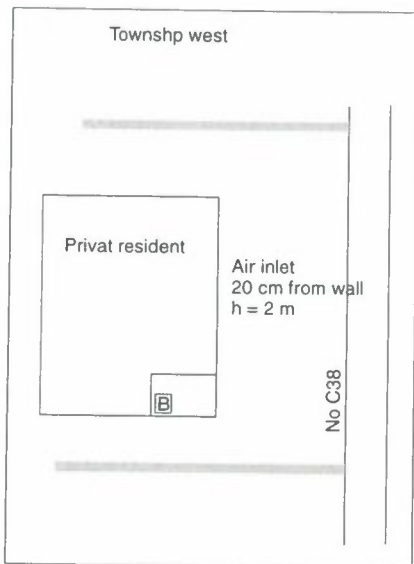

Air quality monitoring network Site visit report

Site Name	: Water Utilities Corporation
Co-ordinates	: S: 21°56'26s E: 27°51'32s UTM: 355886(x) - 3575746(y)
Access/availability	: Easy access. Fenced. Need permission to get through gate. parking on Water Utilities Corporation properties.
Buildings and rooms available	: Sampler located in a small elevated wooden box close to a bassin, 2 m below ground level. Space enough to put up a shelter?
Area description	: Industrial area? 10 m from road inside industrial area on WUC-property. Concrete ground. The BCL smelter is approximately 300 meter NW (305°) of the station.
Local sources	: BCL; 300 meter NW (305°).
Representativity	: The site is representative for the diffuse emissions from the BCL smelter.
Parameters measured	: SO₂.
Data quality	: The maintenance of the instrument was generally poor.
Measurement equipment	: Old type sequential sampler (bubbler) from AGL Engineering in England (4 bottles) for 24 h average sampling of SO₂.
Infrastructure	:
Power	: 220 V
Telephone lines	: -
Sampler/monitor locations:	: 1 m above ground level.
Air intake	: 1.0 m above the ground.
Personnel	: Mr. Jo Madumela (BCL smelter) is responsible for the collection of the bottles. Analysis are performed at the BCL laboratory.
Future monitoring station	: The site could be used to measure SO₂ and represent low and diffuse emissions. It should, however, be slightly relocated.

Air quality monitoring network Site visit report

Site Name : Water Utilities Corporation
Co-ordinates : S: 21°56'26s E: 27°51'32s UTM: 355886(x) - 3575746(y)



Sampler location

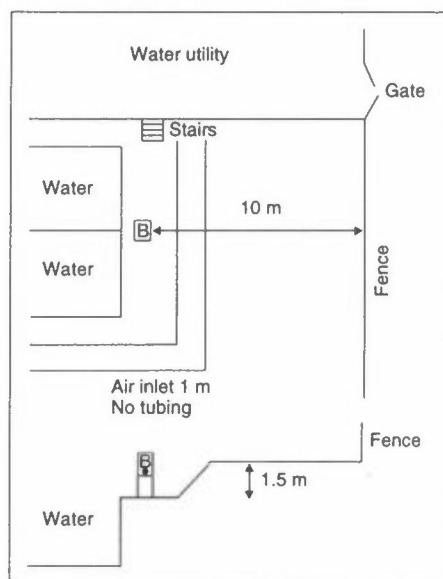

Air quality monitoring network Site visit report

Site Name : Water Utilities Corporation
Co-ordinates : S: 21°56'26s E: 27°51'32s UTM: 355886(x) - 3575746(y)



Air quality monitoring network Site visit report

Site Name	: Makobe Hill Junior Secondary School
Co-ordinates	: S: E: UTM:
Access/availability	: Easy access. Turn right from main road to Mmadinare. 500 m from main road. Sandy road. Station is locked. Need key from DoM.
Buildings and rooms available	: Separate shelter (2x3x2.5 m) inside fenced area on school property. 2 rooms inside shelter. Air-conditioned.
Area description	: Close to school buildings. Sandy ground. Some small hills ca. 180 m SE of station. Medium dense vegetation N, W and E. 6 m tall trees 2 m away from monitoring station.
Local sources	: School kitchen. Burning of wood and waste?
Representativity	: Background. Rural. Put up to measure influence from BCL.
Parameters measured	: Meteorology (FF, DD, RH, T) at 9 m. SO₂ and CO.
Data quality	: Meteorological tower is not wired to the ground. The tower might meander in strong winds, causing large σ-values. T_{inside}=27°C and T_{outside}=33°C.
Measurement equipment	: Sierra Hi-Vol (10 μm cut-off) PM₁₀ (24 hr). The laboratory personnel from Selebi-Phikwe change the filter every day. R. M Young Sensor Interface (meteorology); Wind model 05103; TCL temperature sensor Model 3503. Monitor Lab (CO, SO₂). PC equipment: Macer (monitor), Macer 6000 (Hard disk).
Infrastructure	:
Power	: 220 V
Telephone lines	: Not now. Possible to get from school building. DoM will apply for telephone line in 1-2 weeks time.
Sampler/monitor locations	: On top of 0.8 m bench inside shelter.
Air intake	: 5 m above the ground.
Personnel	: Mr. A. M. Mukuwa and Mr. S. M. Sereetsi collects the data on diskette and bring them to Selebi-Phikwe for plotting and storing (backup on hard disk at Selebi-Phikwe laboratory and on diskette).
Future monitoring station	: This monitoring station is suitable to monitor SO₂ impacts from the tall BCL-stack.

Air quality monitoring network Site visit report

Site Name : Makobe Hill Junior Secondary School
Co-ordinates : S: E: UTM:

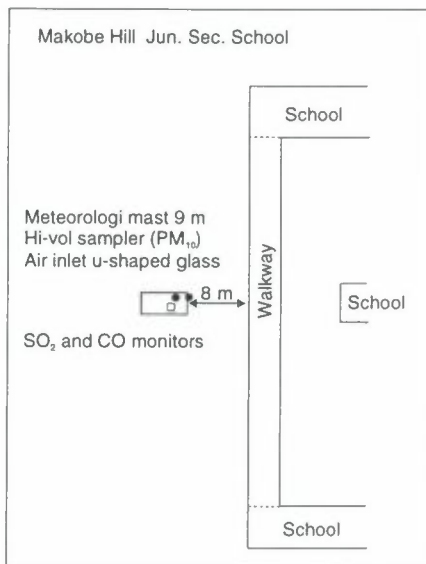
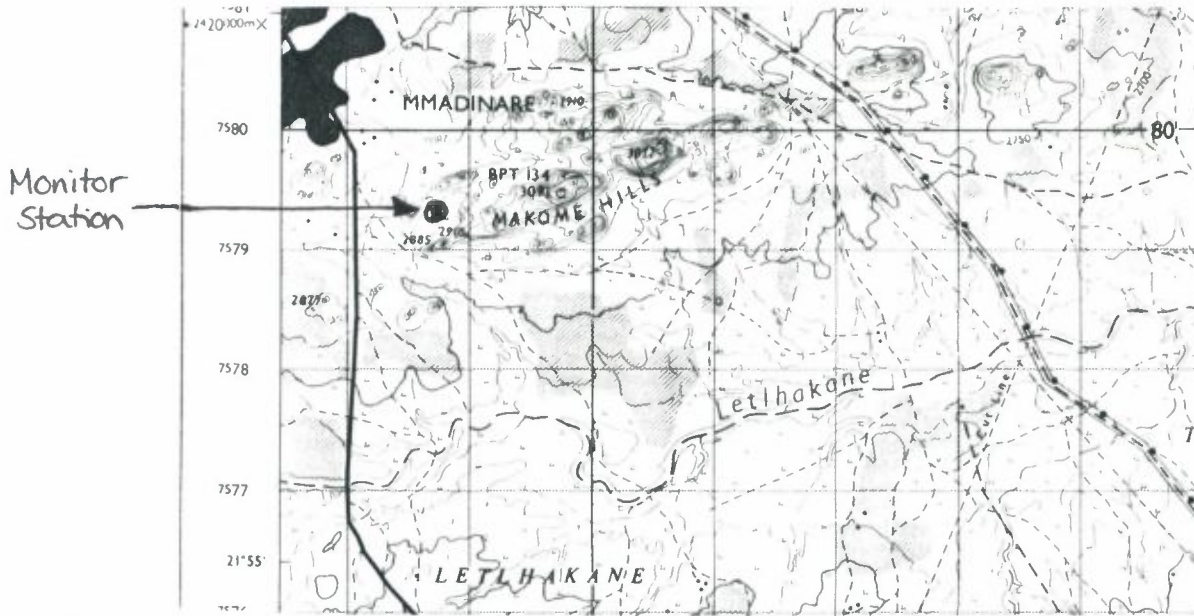

Mmadinare



Kitchen !



Air quality monitoring network Site visit report

- Site Name** : Possible kerb side station in Francistown
Co-ordinates : S: 21°09'47s E: 27°30'38s UTM: 355521(x) - 3576599(y)
- Access/availability** : Easy access. Main road through downtown Francistown. Very busy at rush hours in morning, during lunch hours and in the evening. Parking along street. The site is fenced and access is available through main. The possible station location is at Botswana Telecom property. Will need permission from Botswana Telecom.
- Buildings and rooms available** : Available space for shelter (2x3x2.5 m) inside fenced area. Building at property used to belong to Dept. of Transport and Registration. The building is not occupied at the moment, but is rented by Botswana Telecom.
- Area description** : Two story buildings along main street. One story buildings at Botswana Telecom property around possible curb-side station location. Traffic light 3 m from possible location. The main road is the most trafficated road in Francistown. Pedestrian on each side of the road. The east side of the town is a low density area. One block west of the city center there is a less trafficated shopping street with parking possibilities.
- Local sources** : Traffic. Possible hospital (~160° from station)? Brewery north?
Hospital, 1 high stack, coal fired, produce steam; 1 low stack, incinerator.
- Representativity** : Curb side/ traffic.
- Parameters measured** : None at the moment.
- Data quality** : None.
- Measurement equipment** : Monitors.
- Infrastructure** :
- Power** : 220 V
- Telephone lines** : Possible through Botswana Telecom buildings 50-100 m from possible station location.
- Sampler/monitor locations** :
- Air intake** : 2 m above the pedestrian, 3 m from road, 8 m from crossing (traffic light).
- Personnel** : Mr. A. M. Mukuwa and Mr. S. M. Sereetsi would be responsible for this station.
- Future monitoring station** : This site is suitable to measure NO_x, CO, PM₁₀, SO₂.

Air quality monitoring network Site visit report

Site Name : Possible kerb side station in Francistown
Co-ordinates : S: 21°09'47s E: 27°30'38s UTM: 355521(x) - 3576599(y)

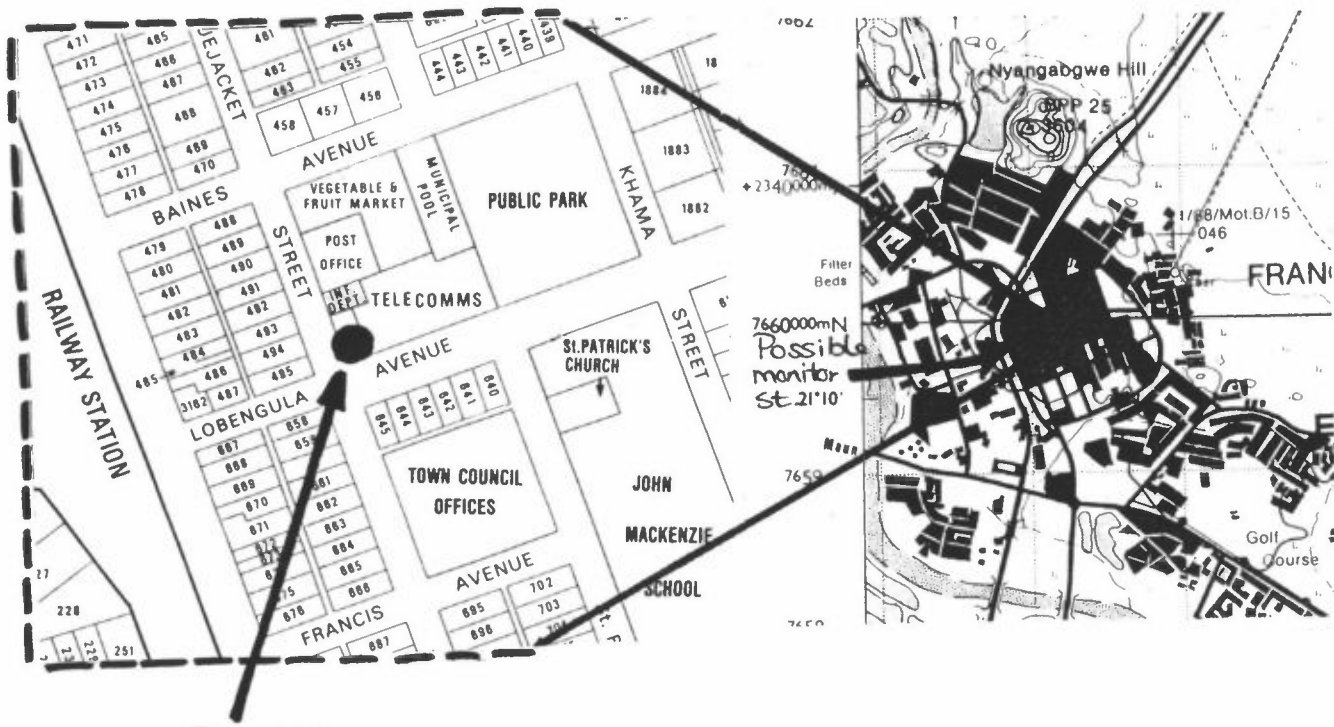

Possible monitoring station

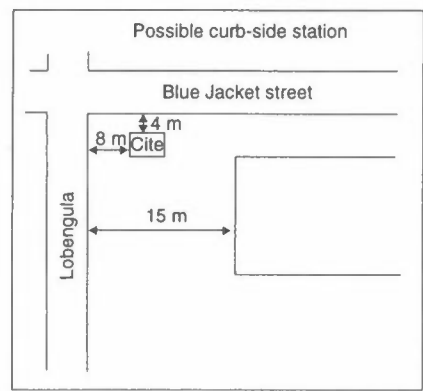





Air quality monitoring network Site visit report

Site Name	: Francistown Town Council
Co-ordinates	: S: 21°09'44s E: 27°30'04s UTM: 355520(x) - 3576600(y)
Access/availability	: Easy access. Fenced parking on FTC property. Need permission from DoM and possibly FTC to enter FTC property.
Buildings and rooms available	: Outside FTC building. Relocate to shelter?
Area description	: Trafficated area. Trucks on parking lot close to the industrial site and air intake. Many buldings and some bushes close to air intake. Small industrial buildings around (2-3 stores). Sand/gravel ground.
Local sources	: Botswana Brewery (3 stacks), coal fired, approximately 0.5 km ENE.
Representativity	: Industrial.
Parameters measured	: TSP (4 hrs a day in one week on the same filter), SO₂.
Data quality	: -
Measurement equipment	: Old type sequential sampler (bubbler) from AGL Engineering in England (8 bottles) for 24 h average sampling of SO₂. The bottles are changes once a week. 1 "blind" sample. Sierra Hi-Vol (TSP).
Infrastructure	:
 Power	: 220 V
 Telephone lines	: Yes
 Sampler/monitor locations:	: 0.3 m above sandy ground in wooden box outside FTC building.
 Air intake	: SO₂: 1.5 m above ground level, 0.2 m from building wall, 2 m below roof. TSP: 1 m above ground.
Personnel	: Mr. A. M. Mukuwa and Mr. S. M. Sereetsi collects the samples for this station and brings them to DoM laboratory in Selebi Phikwe for analysis.
Future monitoring station	: This station is not suitable for measurements.

Air quality monitoring network Site visit report

Site Name : Francistown Town Council

Co-ordinates : S: 21°09'44s E: 27°30'04s UTM: 355520(x) - 3576600(y)

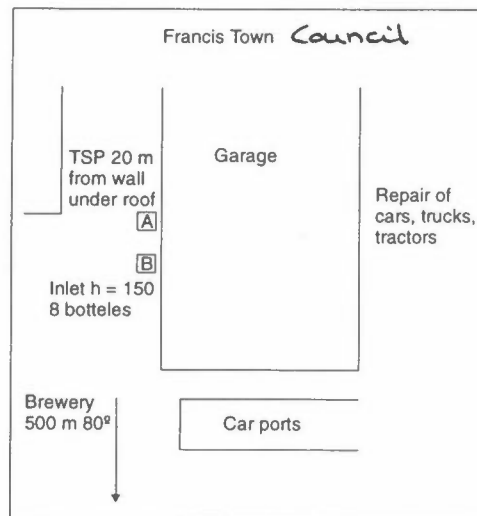
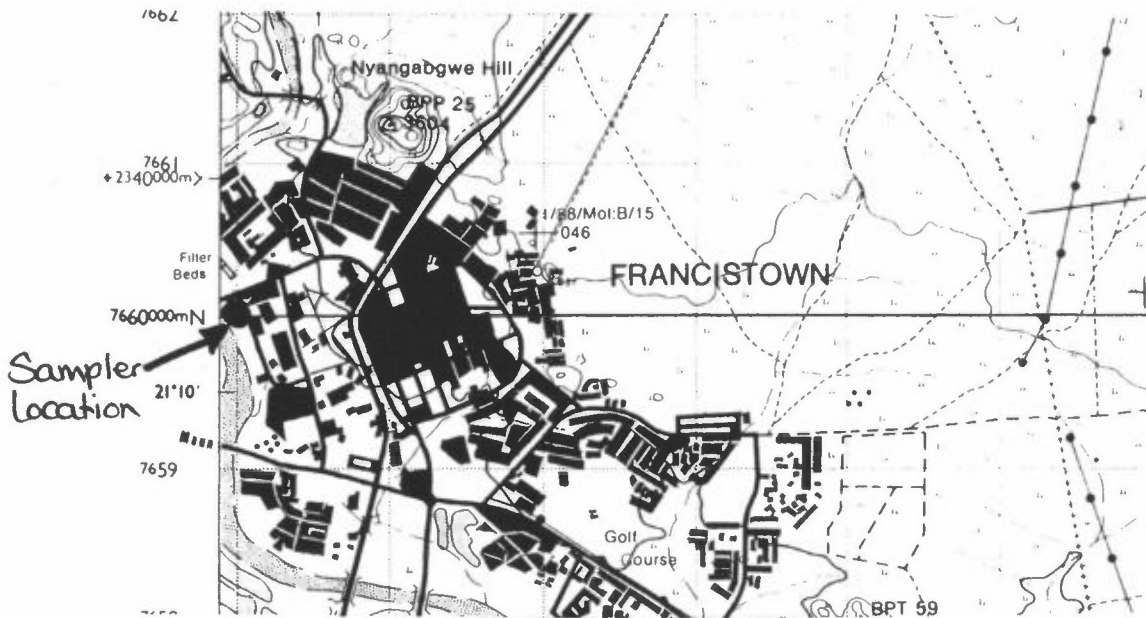



Heavy
truck
loading
(right
side of
fence)

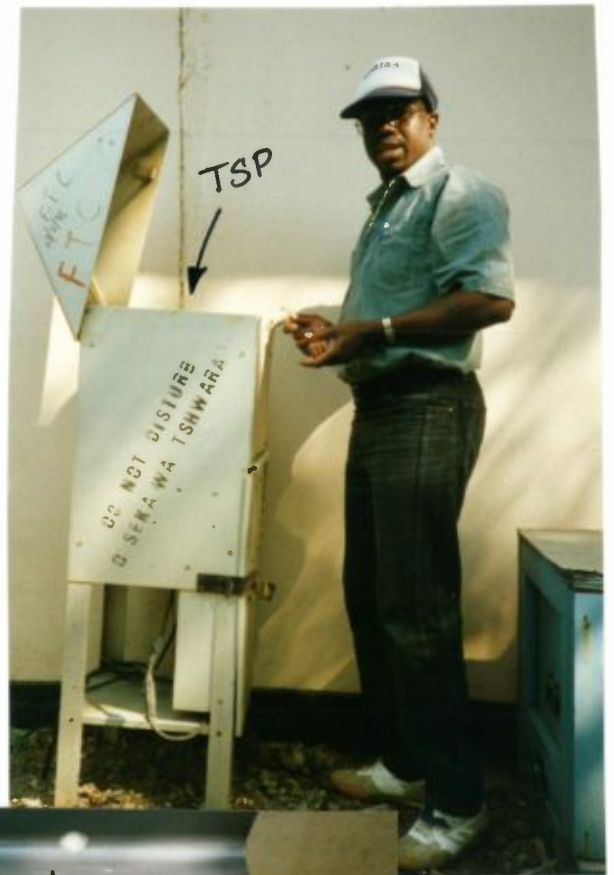



Air quality monitoring network Site visit report

Site Name	: Francistown Airport
Co-ordinates	: S: 21°09'37s E: 27°29'15s UTM: 355506(x) - 3576602(y)
Access/availability	: Easy access. Close to airport terminal. Parking outside Francistown Airport Meteorological Office. Need permission from airport authority to enter site.
Buildings and rooms available	: None.
Area description	: Flat. Some bushes (5 m). Grass lawn.
Local sources	: -
Representativity	: Open, flat terrain
Parameters measured	: Meteorology ; FF (2, 12 m), DD (12 m), T (1.5), radiation (2 m).
Data quality	:
Measurement equipment	: Vaisala meteorological equipment.
Infrastructure	:
Power	: 220 V
Telephone lines	: Yes
Sampler/monitor locations	: Open, flat terrain, 80 m from meteorological office building.
Air intake	: None
Personnel	: Mr. G. G. Mbaiwa (Chief technical assistant) and Mrs. Patricia G. Mbikisa (Technical assistant).
Future monitoring station	: This site is well located for meteorological measurements and possibly O ₃ .

Air quality monitoring network Site visit report

Site Name : Francistown Airport
Co-ordinates : S: 21°09'37s E: 27°29'15s UTM: 355506(x) - 3576602(y)

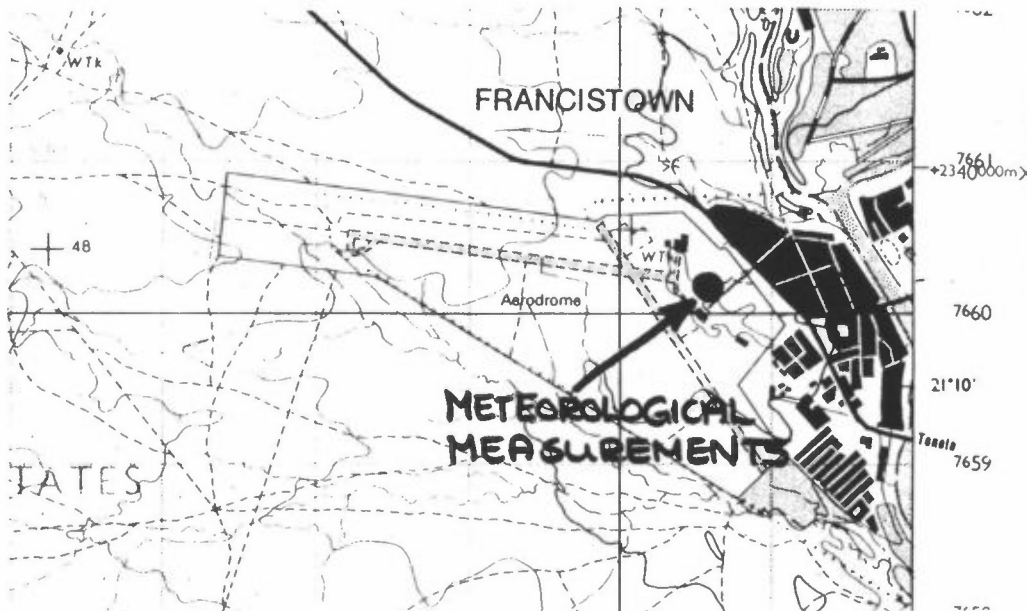



Outside meteorological
office at airport
in Francistown



Air quality monitoring network Site visit report

Site Name	: Tonota	
Co-ordinates	: S:	E: UTM:
Access/availability	:	Easy access. Inside fenced area on Tonota College of educations' premises. Close to gate. Locked separate shelter (2x3x2.5 m). Need key from DoM.
Buildings and rooms available	:	Separate shelter (2x3x2.5 m). Two rooms inside shelter. Air-conditioned.
Area description	:	Sandy ground, sparsely gras covered. Some bushes 12-15 m away. Water Tower (H=20 m) approximately 40 m ENE of monitoring station.
Local sources	:	Burning of wood.
Representativity	:	Background, open flat terrain. Put up to monitor the influence from the BCL smelter in Selebi-Phikwe. Problems with condensation in teflon tubings because of too low temperature inside the shelter compared to outside air temperature ($T_{\text{inside}}=20.5^{\circ}\text{C}$, $T_{\text{outside}}=32.4^{\circ}\text{C}$)
Parameters measured	:	Meteorology; FF and DD (8 m), T (5 m), gust, RH, σ and SO_2 .
Data quality	:	The meteorological tower should be wired to the ground. Meandering of the tower could lead to overestimated σ -values. DoM has prohibited burning of waste and gras close to the monitoring station.
Measurement equipment	:	R. M Young Sensor Interface (meteorology); Wind model 05103, TCL-temperature sensor Model 3503. Monitor lab 9850 (SO_2) Monitor Lab 9508 (Calibrator). PC equipment: Mecer (screen), Mecer 6000 (Hard disk).
Infrastructure	:	
Power	:	220 V
Telephone lines	:	Absolutely necessary. Mr. C. Matala thinks that it is possible, but have to apply at Botswana Telecom.
Sampler/monitor locations	:	On 0.8 m bench inside room in shelter.
Air intake	:	5 m above ground level. FF, DD 8 m above ground.
Personnel	:	Mr. A. M. Mukuwa and Mr. S. M. Sereetsi collects the data every weeks on diskette and brings the data to Selebi-Phikwe for plotting and backup.
Future monitoring station	:	This site is suitable to measure SO_2 with a monitor for long distances transport of pollutants from the BCL-stack.

Air quality monitoring network Site visit report

Site Name : Tonota
 Co-ordinates : S: E: UTM:

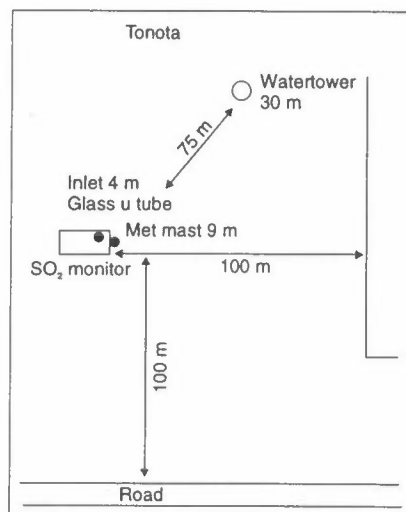
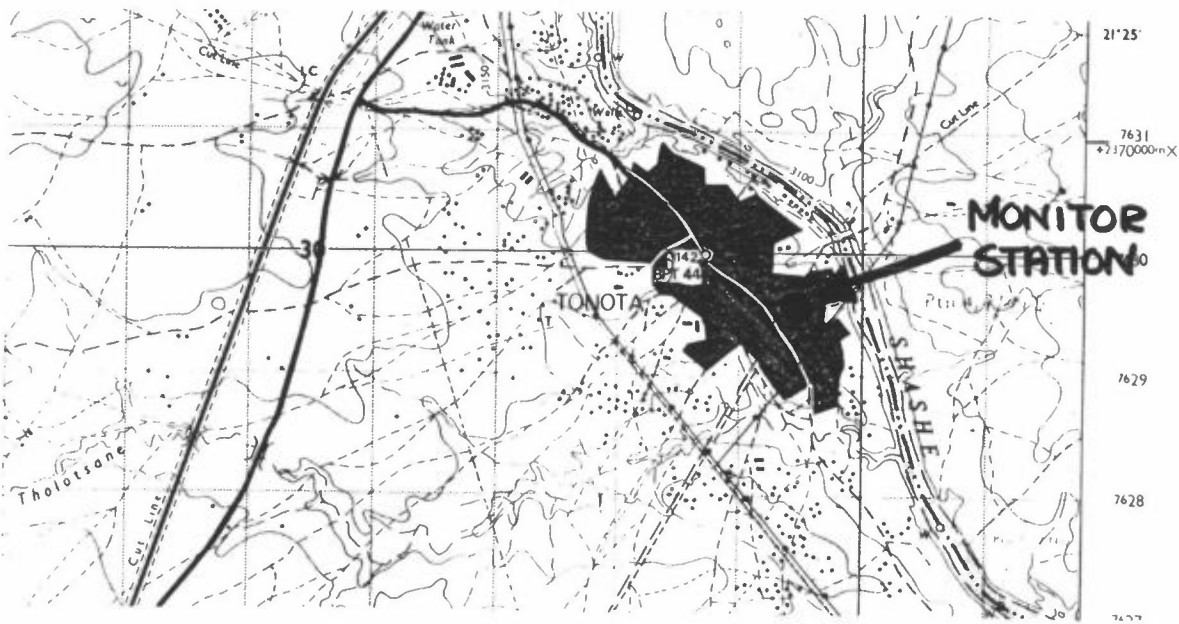

Air quality monitoring network Site visit report

Site Name : Tonota
Co-ordinates : S: E: UTM:

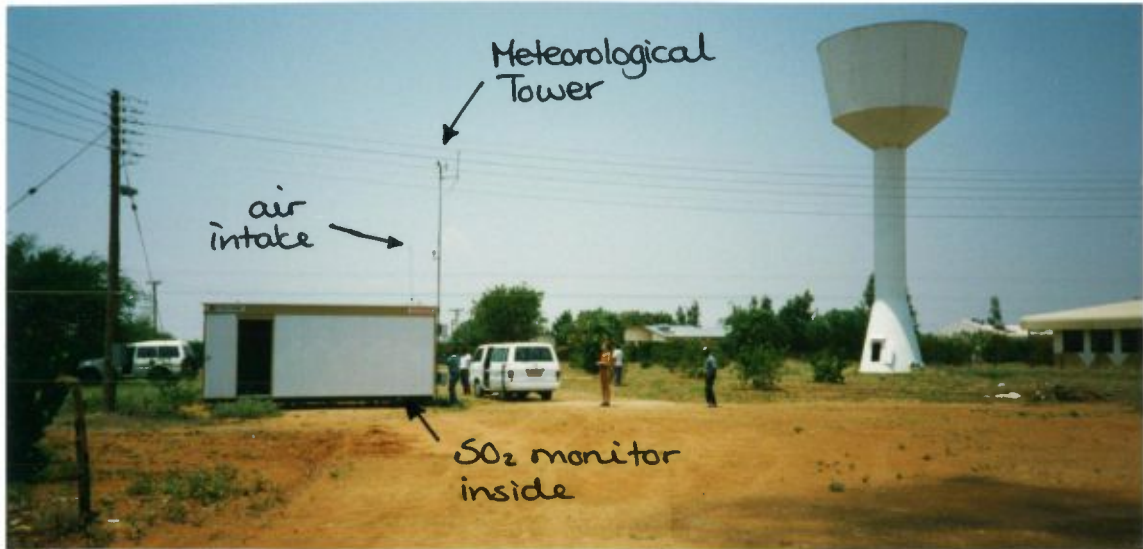

Air quality monitoring network Site visit report

Site Name	: Palapye Primary Hospital
Co-ordinates	: S: E: UTM:
Access/availability	: Easy access. Parking outside monitoring station at hospital properties. Locked separate small shelter (1x0.5x1.5 m). Need key from DoM.
Buildings and rooms available	: Shelter (1x0.5x1.5 m). Available rooms possible inside hospital??
Area description	: Sandy. Big tree at side of air intake and measurement station. Sparsely vegetated (trees) on site. No large roads close by. Hospital buildings.
Local sources	: Incinerator 40 m WSW (3 m stack). Power plant 10 km NW. Boiler (coal fired, black coal) 200-300 m SSW. Not in operation at the moment.
Representativity	: Residential area. Background originally.
Parameters measured	: SO ₂ and TSP.
Data quality	: ??
Measurement equipment	: Old type sequential sampler (bubbler) from AGL Engineering in England (4 bottles) for 24 h average sampling of SO ₂ . Sierra Hi-Vol (TSP).
Infrastructure	:
Power	: 220 V
Telephone lines	: Available 50-100 m away?
Sampler/monitor locations	: Vegetated. Fairly open flat terrain.
Air intake	: SO ₂ : 1.9 m above ground level. TSP: 2.5 m above ground.
Personnel	: Mr. A. M. Mukuwa and Mr. S. M. Sereetsi collect the samples for this station and bring them to DoM laboratory in Selebi Phikwe for analysis.
Future monitoring station	: The site is representative for emissions from a local hospital (residential) SO ₂ , NO _x , PM ₁₀ .

Air quality monitoring network Site visit report

Site Name : Palapye Primary Hospital
Co-ordinates : S: E: UTM:

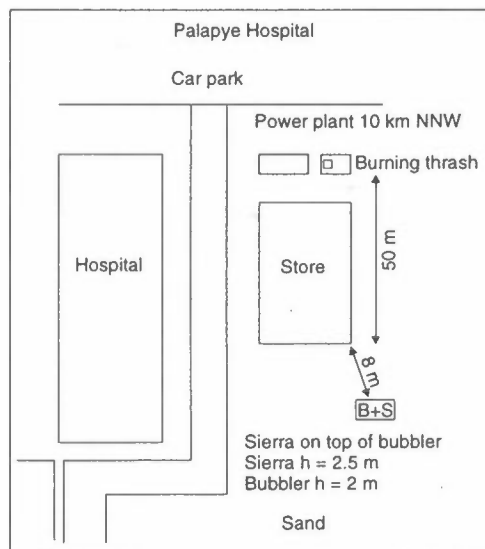
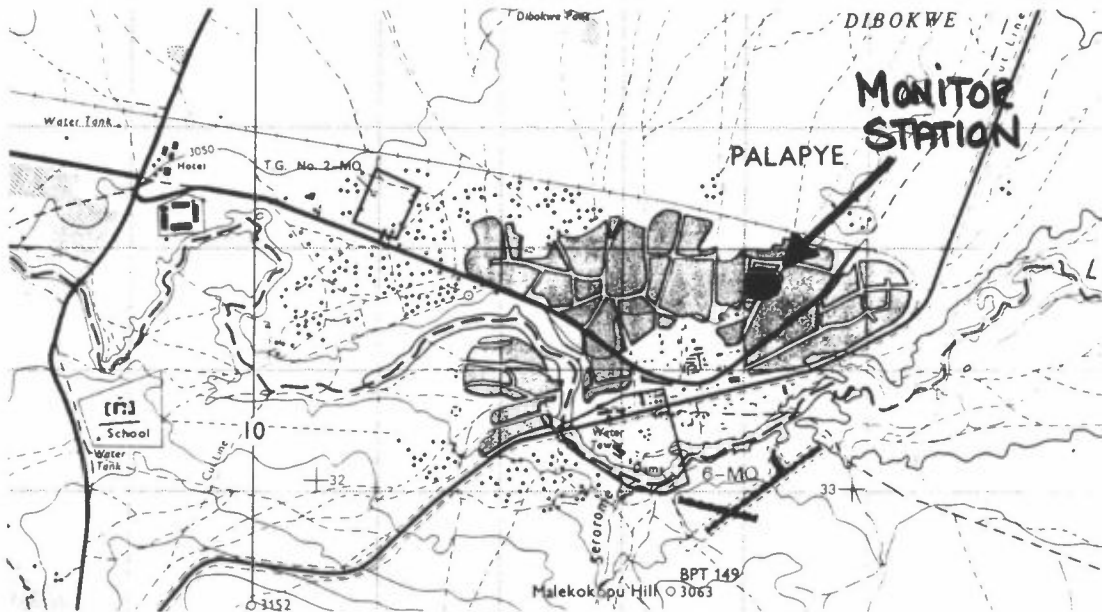

Air quality monitoring network Site visit report

Site Name : Palapye Primary Hospital
Co-ordinates : S: E: UTM:



Burning of waste

Air quality monitoring network Site visit report

- Site Name** : Serowe Teacher Training College
Co-ordinates : S: 22°23'58s E: 26°41'34s UTM: 354684(x) - 3575231(y)
- Access/availability** : Approximately 44 km from Palapye. End of Sam-Sam (?) road. Inside fenced College area. Government property. Need key from DoM.
- Buildings and rooms available** : Separate shelter. 2 rooms inside shelter. Air conditioned.
- Area description** : Buildings 20-100 m away. No large roads close to the stations. Flat, sandy, sparsely vegetated with some trees. Vegetation approximately 50 m away.
- Local sources** : No local sources around.
- Representativity** : Background. Put up to see the effect of Botswana Power Coperation. In the main wind direction of BPC.
- Parameters measured** : Meteorology (FF, DD, RH, T, gust) at ca. 10 m above ground. CO, SO₂ and NO_x.
- Data quality** : Problems with power failure (interruption) at least once a week. The power failure usually lasts less than 30 minutes, but could sometimes last for several hours because of maintenance of the power system. UPS (Uninterrupted Power Source/Supply) will be installed week 3 of November 1996. The meteorological tower is properly rigged. All the data for this station is on the hard-disk of the PC inside the monitoring station. There exist no backup of the data. T_{inside}=21°C, T_{outside}=33°C.
- Measurement equipment** : Aanderaa for measurement of metorology. Display unit 3017 (VR22/SR10 Sensors). Horiba instruments for measurements of CO, SO₂ and NO_x. Horiba APMA-350E (CO), Horiba APSA-350E (SO₂) and Horiba APNA-350E (NO_x).
 PC equipment: HP Super VGA (monitor), HP Vectra VL2 4/50e (Hard disk), HP DeskJet 560 (Printer).
- Infrastructure** :
- Power** : 220 V
- Telephone lines** : Have applied for telephone at Botswana Telecom. All lines are occupied. Depends on expansion of Botswana Telecom for the area.
- Sampler/monitor locations** : On bench inside shelter, 0.8 m above floor.
- Air intake** : 3 m above the ground (2.5 m above ground and 0.5 m above shelter roof).
- Personnel** : Mr. A. M. Mukuwa and Mr. S. M. Sereetsi go to station once a week to print out the monitoring results.
- Future monitoring station** : The site is representative for the power plant and should monitor SO₂ and meteorology.

Air quality monitoring network

Site visit report

Site Name : Serowe Teacher Training College
Co-ordinates : S: 22°23'58s E: 26°41'34s UTM: 354684(x) - 3575231(y)

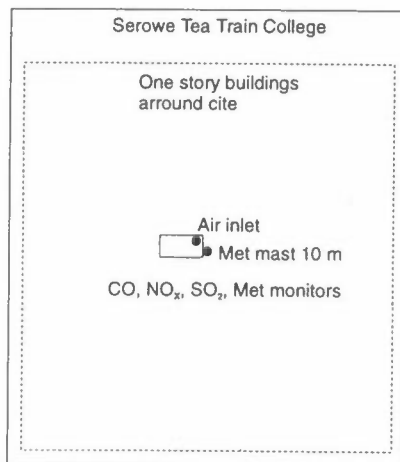
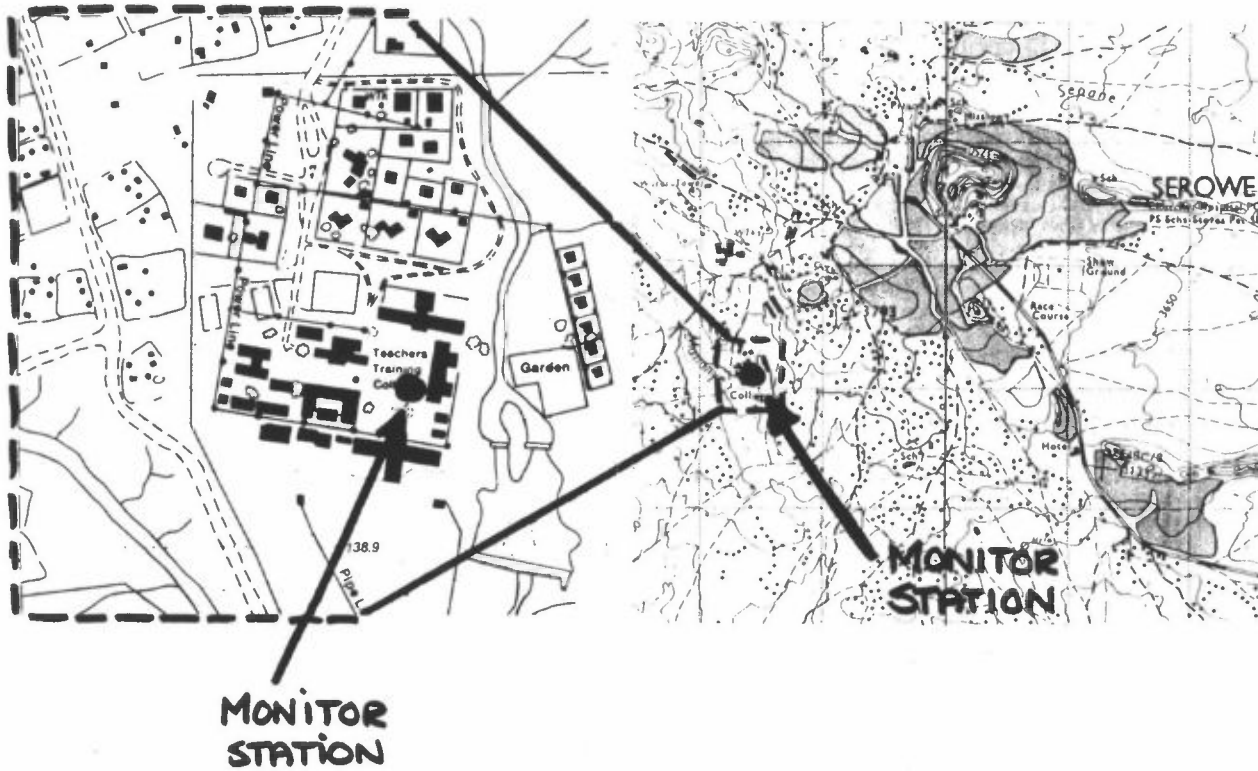

Air quality monitoring network Site visit report

Site Name : Serowe Teacher Training College
Co-ordinates : S: 22°23'58s E: 26°41'34s UTM: 354684(x) - 3575231(y)



Air quality monitoring network Site visit report

Site Name	: Lobatse
Co-ordinates	: S: 25°13'54s E: 25°40'07s UTM: 353659(x) - 3572091(y)
Access/availability	: Easy access. Parking outside Shell station. The monitors are inside 4x4 m fenced area outside public toilet. Need key from DoM.
Buildings and rooms available	: Two wooden boxes inside metal shelter.
Area description	: Bus terminal 50 m to the west (diesel/oil??). Sandy, some 20 cm grass, flat. One-story building (public toilet) 5 away (30x60 m). Sparsely vegetated. 3-6 m tall trees. Dry river NE-SW 100 m away from station. Gas station (Shell) + parking NNE 60-100 m. Mountaineous region. Channelling of the wind in the NE-SW direction along vally/dry river.
Local sources	: Botswana Meat Commision 1 km to the north. Gas station 60-100 m away in main wind direction (VOC?). Lobatse Tannery (produse skin for shoes etc.?) Brewery west ~2-3 km. Lobatse Clay Works 2.5-3 km east (parafin, diesel?). Bus station 50 m west. Burning of waste?
Representativity	: The station was put up to get an idea of the overall pollution in the Lobatse area.
Parameters measured	: SO₂ (24h), TSP.
Data quality	: The Sierra Hi-Vol was fairly clean. Fair maintenance, but some dust inside sampler. The glas bottles seemed clean.
Measurement equipment	: Old type sequential sampler (bubbler) from AGL Engineering in England (8 bottles) for 24 h average sampling of SO₂. Sierra (Hi-vol) for measurement of TSP.
Infrastructure	:
Power	: 220 V
Telephone lines	: Probably possible (6 m away on roof of lavatory building).
Sampler/monitor locations	: SO₂: 1 box with 4 samples 0.2 m above ground level.; 1 box with 4 samples 0.7 m above the ground. TSP: At ground level.
Air intake	: 1.75 m above the ground.
Personnel	: Mr. D. Mmolawa and Mr. Tshukudu drives to Lobatse once a week to collect samples (8 samples in shelter) and bring to DoM laboratory in Gaborone for plotting and storing.
Future monitoring station	: The site is suitable for SO₂, TSP, NO_x, CO.

Air quality monitoring network Site visit report

Site Name : Lobatse
Co-ordinates : S: 25°13'54s E: 25°40'07s UTM: 353659(x) - 3572091(y)

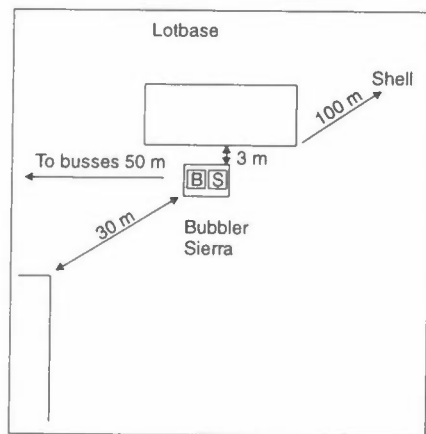
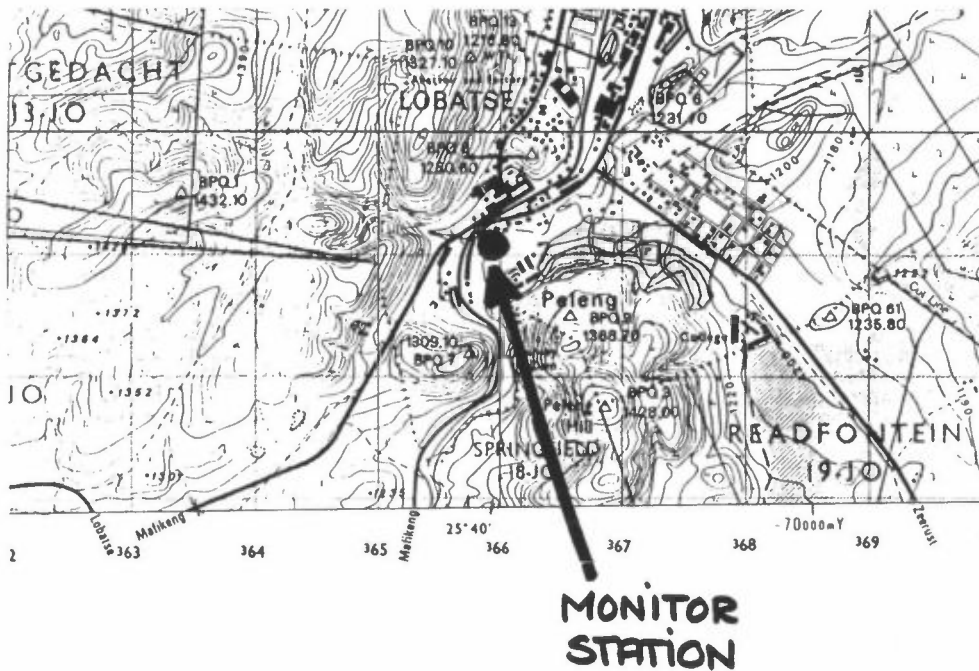



Air quality monitoring network Site visit report

Site Name	: Gaborone Fire Brigade
Co-ordinates	: S: 24°39'21s E: 25°54'01s UTM: 353888(x) - 3572728(y)
Access/availability	: Easy access. From Nelson Mandela and Molepolole road. Parking on grass lawn outside monitoring station. Shelter is locked. Need key from DoM.
Buildings and rooms available	: Separate shelter (2x3x2.5 m). 1 room inside shelter. Air conditioned.
Area description	: Densely trafficated road (Molepolole rd.) 25 m to the N, 4 lanes. Flat, sandy grass lawn (10-50 cm grass). Fairly open area, with scarce vegetation and few buildings around the measurement site. Bus terminal 200 m to the SE. Train station (Ring road) 500 m to the SE. Fire brigade station 100 m to the SE.
Local sources	: Traffic. Bus terminal?? Industry?? Train station (diesel)??
Representativity	: Traffic.
Parameters measured	: CO, NO_x and HC (1 hr average). SO₂
Data quality	: ??
Measurement equipment	: Monitor Lab 9841A (NO_x), Monitor Lab 9830 (CO), Dasibi Environmental Corporation Model 302 (HC). PC equipment: Acer Viewer 34T UVGA (monitor), Acer Open (Hard disk).
Infrastructure	:
Power	: 220 V
Telephone lines	: Possible from Gaborone Fire Brigade 100 m away..
Sampler/monitor locations	: On bench inside shelter, 0.8 m above floor.
Air intake	: 3.5 m above the ground. 25 m from road.
Personnel	: Mr. M. D. Mmolawa and Mr. Tshukudu collects data from the monitors every day and brings them to DoM for plotting (printout of daily time plots) and archiving. The data are copied to a hard disk at DoM.
Future monitoring station	: The site is representative for meteorological measurements and NO_x, CO, PM₁₀.

Air quality monitoring network Site visit report

Site Name : Gaborone Fire Brigade
Co-ordinates : S: 24°39'21s E: 25°54'01s UTM: 353888(x) - 3572728(y)

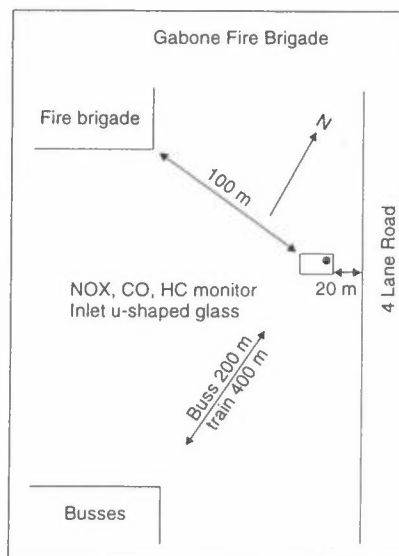

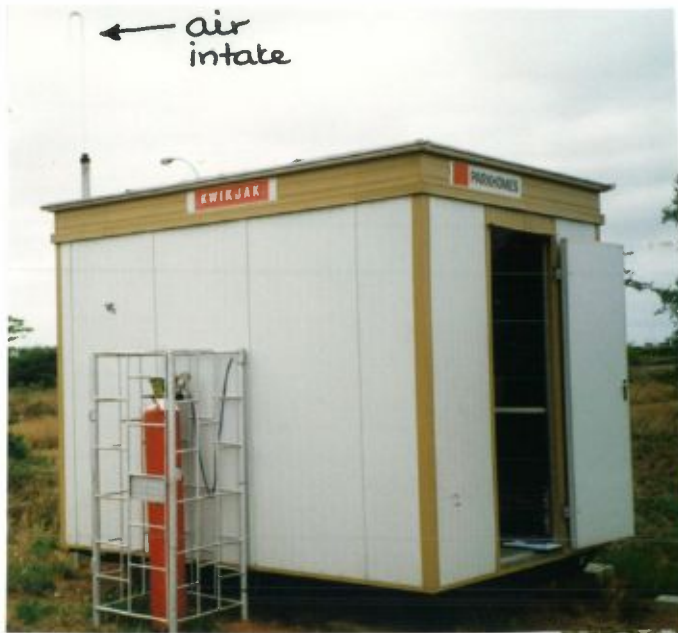

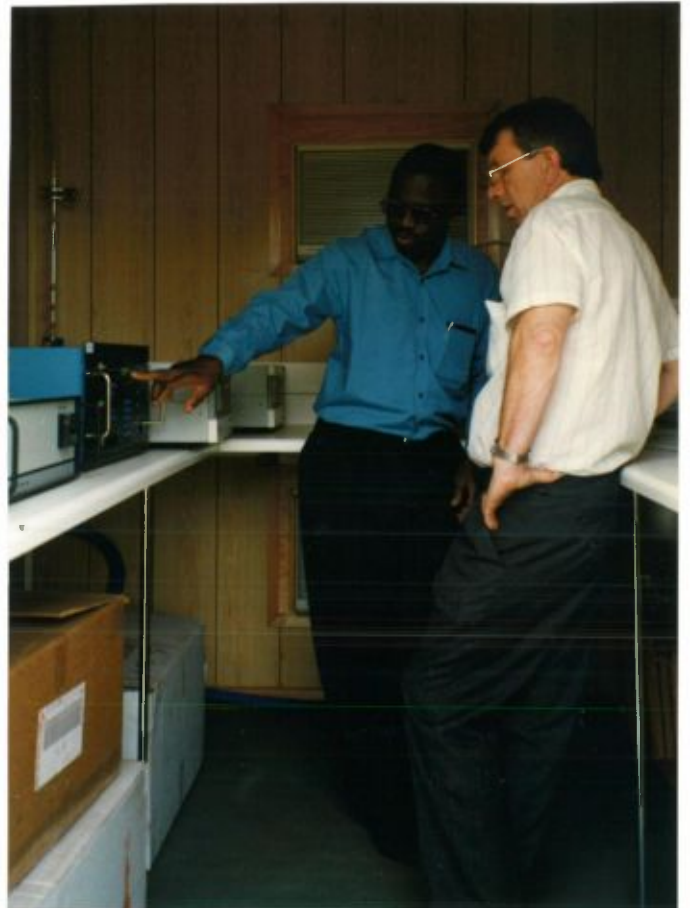

Air quality monitoring network Site visit report

- Site Name** : Therisanyo Primary School (Naledi District), Gaborone
Co-ordinates : S: 24°40'39s E: 25°54'14s UTM: 353891(x) - 3572704(y)
- Access/availability** : Easy access. Parking on school properties. Fenced. Shelter is locked. Need key from DoM.
- Buildings and rooms available** : Separate shelter (2x3x2.5 m). 1 room inside shelter. Air conditioned.
- Area description** : Sandy/gravel ground. School buildings 8-10 m and 20 m away. Traffic light 200 m away E. High density area. Trafficated road 10 m (New Lobatse rd.).
- Local sources** : Traffic. Industrial area 150 m north of monitoring station across road. Waste burning and coal firing during winter time.
- Representativity** : Traffic.
- Parameters measured** : SO₂ (24h) and PM₁₀.
- Data quality:**
- Measurement equipment** : SO₂ bubbler (24 h) on floor inside the shelter. 8 bottles? The SO₂ bubbler is the only instrument inside the shelter yet. More instruments will be installed soon. Grasby Andersen (PM₁₀) 20 m from road.
- Infrastructure** :
- Power** : 220 V
- Telephone lines** : Possible from school.
- Sampler/monitor locations** : On bench inside shelter, 0.8 m above floor.
- Air intake** : 3.5-4 m above the ground. 10 m from road. Some short trees/grass between road and shelter (air intake).
- Personnel** : Mr. D. Mmolawa and Mr. Tshukudu picks up data from the monitors every day and brings them to DoM for plotting and storing.
- Future monitoring station:** : This site is representative for a high density residential area and should measure SO₂, NO_x and PM₁₀.

Air quality monitoring network Site visit report

Site Name : Therisanyo Primary School (Naledi District), Gaborone
Co-ordinates : S: 24°40'39s E: 25°54'14s UTM: 353891(x) - 3572704(y)



**MONITOR
STATION**

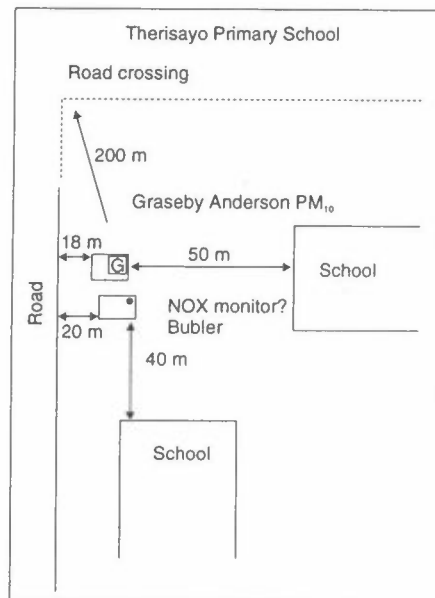

SO₂ sampler



Gaborone



Air quality monitoring network Site visit report

Site Name	: Civic Center
	Co-ordinates : S: 24°39'21s E: 25°55'09s UTM: 353907(x) - 3572728(y)
Access/availability	: Easy access. Parking outside Civic Center. Shelter is locked. Need key from DoM.
Buildings and rooms available	: Separate shelter (2x3x2.5 m). 1 room inside shelter. Air conditioned.
Area description	: Densely trafficated road 5 m (Queens rd.). Traffic light 7 m. Road crossing 10 m from station. Flat, grass lawn, small trees (1.2 m high).
Local sources	: Traffic. Coal fired hospital to the SE.
Representativity	: Traffic. Urban.
Parameters measured	: O ₃ , NO _x , SO ₂ (24h) and HC (CH ₄ , NMHC).
Data quality	: The SO ₂ bubbler and the wooden shelter box is very clean. The best bubbler in operation in Botswana.
Measurement equipment	: Monitor Lab 9812 (O ₃), Monitor Lab 9841A (NO _x), Monitor Lab 9850 (SO ₂), Monitor Lab 9507 (NO ₂ Permetion single point check). Monitor Lab 9508 9507 (SO ₂ Permetion single point check). Dasibi environmental corporation Model 302. Sabio engineering inc. Model 1001. SO ₂ bubbler (24 h) on floor inside.8 bottles. PC equipment: Acer Viewer 34T UVGA(monitor), Acer Open (Hard disk).
Infrastructure	:
Power	: 220 V
Telephone lines:	Possible from Civic Center 50 m away.
Sampler/monitor locations:	On bench inside shelter, 0.8 m above floor. SO ₂ bubbler on floor inside shelter in wooden box.
Air intake	: 4 m above the ground. 5 m from road.
Personnel	: Mr. D. Mmolawa and Mr. Tshukudu picks up data from the monitors every day and brings them to DoM for plotting and storing.
Future monitoring station	: This station should be suitable for a curbside station (NO, CO, HC, PM _{10/2.5})

Air quality monitoring network Site visit report

Site Name : Civic Center
Co-ordinates : S: 24°39'21s E: 25°55'09s UTM: 353907(x) - 3572728(y)

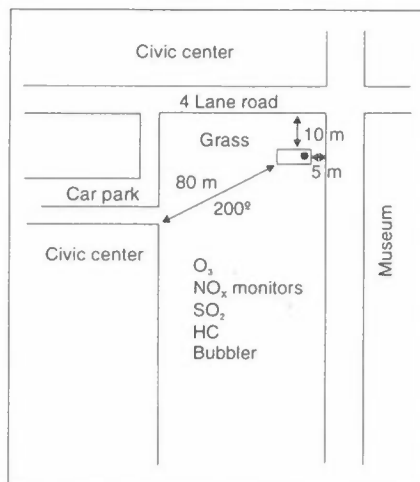
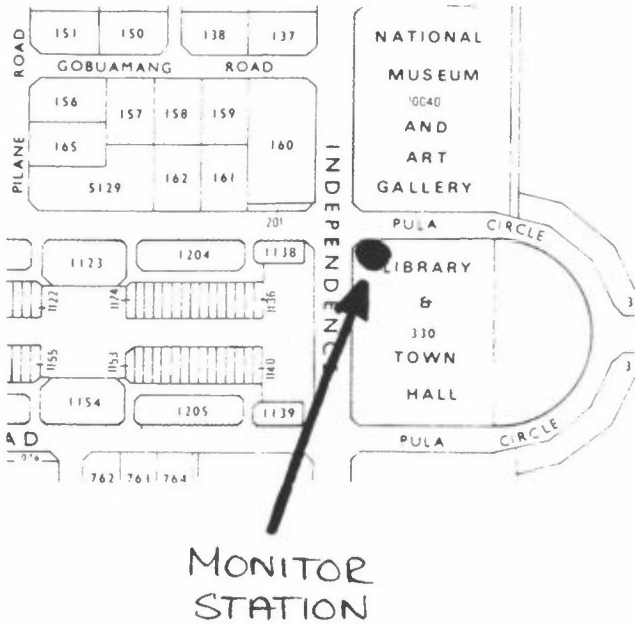





SO₂
Sampler
→



Appendix G

Inventory lists for the laboratories for chemical analysis in Gaborone and Selebi Phikwe

Inventory lists for the laboratories for chemical analysis in Gaborone and Selebi Phikeve

Department of Mines, Gaborone

- Water distillation
Manesty L4, relatively low capacity
- Water purification system
Millipore milliQ plus
- pH-meters
AGB-75 (2 decimals), pH °C mV
mobile pH-meter: Mettler Toledo, pH, conductivity, O₂ in water
- Laboratory balance
Sartorius BP110S (max 110g, 4 decimals)
- Magnetic stirrer, hotplate
Gallenkamp
- Atomic absorption spectrophotometer
Varian SpectrAA 10 plus
Autosampler, max 50 samples
Graphite oven, GTA 96 plus
Pump: Fine compressors (Italy) OL 105, 95 l/min, 0,55kW, max 8 bar
Gas: N₂O, C₂H₂, N₂ (99,9%) (Air Liquide)
Epson LX 400 matrix printer
Plenty of sample tubes
Software for controlling instrument and storing/reporting data (not in use)
- UV/visible spectrophotometer
Varian Cary 1E
Range: 190-900 nm
Bandwidth: 0,2-4 nm
2 sample cells (one is used as reference cell) (type LP 2xTI10Q(M))
Software for controlling instrument and storing/reporting data
PC: 486, 33mhz, 4MB RAM, 260 MB HD, 3½" & 5¼" FD
Printer: Epson LX 300 (colour upgradeable)
- Gas chromatograph/mass spectrum detector (GC/MS) with thermo desorption unit
GC: Varian star 3400 CX
Thermodesorption: Tylan RO-28
Ms: Varian Saturn 3
Gas: He 99,997% (Afrox), compressed air
Storage container for liquid N₂

PC: AcerMate 600, 486DX4, 100 Mhz, 4 MB RAM, 500 MB HD, 3½”
FD

Sample cyls.: SIS (Scientific Instruments Specialists, Idaho) stainless steel
canisters, 6 l, max 40 psi

- Photometer for sulphate measurements
Merck SQ 118
- Sentrifuge
Heraus Labofuge 400
4 big sample tubes
- Ovens
1 oven, 300 °C
1 muffel oven, 800 °C
- Fume hood
Laboratory Interiors, 1 m wide
- 1 water bath
space for 12 beakers
- 1 exicator
- Refrigerator for storing of H₂O₂
- Glassware
burettes, pipettes, beakers etc.

Laboratory in Selebi Phikwe

- Water distillation
Manesty L4
- pH-meter
Metrohm 632 (Switzerland)
- Laboratory balance
Sartorius BP110S (max 110g, 4 decimals)
- Refrigerator for storing of H₂O₂
- Glassware
burettes, pipettes, beakers etc.

Appendix H

Laboratory measurement programme parameters

Laboratory measurement programme parameters

This list provides a tentative list of parameters which DoM should be in a position to measure at the end of the 3-years of the project. The list is by no means exhausted: evaluation of the list, and other possible parameters to measure, will continue to be updated in accordance with the objectives of the laboratory and the Department of Mines.

Gases

- SO₂, NO₂, HNO₃, NH₃
- Volatile organic compounds (VOCs; light hydrocarbons)
- Ketones and aldehydes
- Polychlorinated Biphenyls (PCBs)
- Polyaromatic Hydrocarbons (PAHs)
- Chlorofluorocarbons (CFCs)
- Pesticides
- Dioxins

Particulates

- Sulphate (SO₄²⁻)
- Nitrate (NO₃⁻)
- Ammonium (NH₄⁺)
- Trace metals
- Silica
- PM₁₀

Precipitation

- Amount
- pH/H⁺
- SO₄²⁻, NO₃⁻, Cl⁻
- NH₄⁺, Ca²⁺, K⁺, Na⁺, Mg²⁺
- Conductivity
- Trace metals

Water/Effluents

- pH
- Acidity, Alkalinity
- Temperature
- Conductivity
- Dissolved oxygen, ammonia
- Bromide, iodide
- Sulphate, Sulphite, Sulphide
- Nitrate, nitrite,
- Chlorine, chloride

-
- Fluoride
 - Biochemical Oxygen Demand (BOD)
 - Chemical Oxygen Demand (COD)
 - Hardness
 - Silica
 - Total dissolved solids (TDS)
 - Total suspended solids (TSS)
 - Total solids
 - Total volatile residue
 - Turbidity.
 - Cyanide
 - Mercury
 - Hexavalent chromium
 - All other metals
 - Phenolic compounds
 - Explosives

Appendix I

Workshop

QA & QC in the laboratory

Air Quality Monitoring and Surveillance Program – Botswana – Workshop: QA & QC in the lab

Meeting at the chemical laboratory at the Department of Mines, Botswana
14 November 1996

Participants:

from DoM : S. M. Mosinyi, K. K. Mogami, K. C. Lenyatso, G. Motshwane

from NILU : O. Hermansen

This notes summarizes the discussion about QA & QC that was held as part of the workshop at the Department of Mines in November 1996.

What is quality assurance and quality control?

Quality assurance, QA

The chemical laboratory at DoM performs chemical analysis and produce results as numbers. The results must have a certain quality to be of any use. To ensure this, you need well defined procedures for all procedures carried out in the laboratory that might influence on the quality of the final data. Certain demands must be set for all chemicals, instruments, volumetric and gravimetric equipment etc. All procedures and requirements must be clearly documented.

Quality control, QC

To be sure of the quality of the data, the data must be controlled. All stages from sampling to the presentation of final results must be checked. This is done through a set of control routines. The control routines must be well documented. The documentation of the control routines and the use of them is part of the QA system.

Quality assurance

Procedures

All laboratory activities which may influence the final results must be documented. This is to ensure that every procedure is carried out the right way and that it will always be carried out the same way. Each activity should only be covered in one procedure. This is to ensure that you still have only one unique description after revision of one or more procedures.

- Sample handling

A procedure for sampling and sample handling should give a unique description of preparation, sampling, handling and storing of samples until they are ready for analysis. Cleaning of sampling and storing equipment should be described, if not covered in procedures for cleaning.

- Method descriptions

All analysis methods should be fully described. The method descriptions should tell in detail what kind of equipment to use and the requirements for the different equipment and chemicals (i.e. purity of chemicals). Operations covered by other standard procedures (i.e. the use of volumetric equipment) should not be explained in the method description but should refer to the standard procedure.

✗

All method descriptions should tell the accuracy of the analysis results.

- Operation and maintenance of instruments

The operation and maintenance of laboratory instruments are normally covered in the instrument manuals. This manuals should be stored close to the instrument or as part of the QA-filing system. If the manuals do not clearly describe how to operate the instruments a simple and concise summarized version should be documented.

- Volumetric and gravimetric equipment

The use of volumetric and gravimetric equipment should be described in detail to ensure the same control and results every time they are used, independent of the person using them.

- Storing of chemicals

Different chemicals have different storing requirements. All chemicals should be stored in closed containers in a dark and dry place. Some chemicals should be stored in a cold place (like H_2O_2). No chemicals should be used after their expiry date.

- Cleaning of glassware

The procedure should tell how glassware is cleaned by soap water and then flushed by de-ionized water. It should also tell how to store clean glassware to avoid contamination from dust.

- Cleaning of laboratory

Dust in the laboratory could become a major source of contamination of samples. A procedure for cleaning of the laboratory should tell how to perform the cleaning and how often.

Traceability

If any of the results from the lab are strange or clearly wrong, it is important to be able to go back and check each step from sampling to final results. Therefore all raw data and intermediate results should be stored together with the information about things that could influence the analysis results. To ease the handling of this information, all samples could be given a unique sample number. A sample form that follows the sample from sampling to final reporting would simplify the backtracking.

Sampling		Sample no.: <i>S045/96</i>
Sample site:	<i>Hakuntsi (st. nr. 18)</i>	
Sample date:	<i>24 February 96</i>	
Sampled by:	<i>SMM</i>	
Notes:	<i>A truck on the opposite side of the river was dumping garbage</i>	
Sample preparation		
Date:	<i>02. feb. 96</i>	
Sign:	<i>GM</i>	
Method:	_____	
Notes:	_____	
Analysis		
Date:	<i>11 February 96</i>	
Sign:	<i>KCL</i>	
Method(s):	<input type="checkbox"/> IC-anions <input type="checkbox"/> IC-cations <input checked="" type="checkbox"/> VOC	<input type="checkbox"/> AAS: <input type="checkbox"/> Fe <input type="checkbox"/> Cu <input type="checkbox"/> Ni <input type="checkbox"/> Co <input type="checkbox"/> Cd <input type="checkbox"/> Mn <input type="checkbox"/> Pb <input type="checkbox"/> Al
Notes:	<i>Some problems with the cooling of the cryotrap</i>	
Data storing		
Date:	<i>15. feb. 96</i>	
Location:	<i>DoM database</i>	
Sign:	<i>KKM</i>	
Notes:	_____	

Figure 11: Sample form example.

Data treatment

All data from the laboratory should be stored in a database and should be easily accessible. It might be a good idea to save all final data in the same database as the data from the monitors.

Manual punching of data is a considerable source of errors and should be avoided if data are available on a digital format.

Personnel

All personnel in the laboratory must have some basic knowledge about their jobs. There should be a list of all personnel telling what jobs they are able to accomplish.

There should be a training program for all new personnel that are going to work in the laboratory. The training program must be well described as a written procedure. A brief sketch of topics covered in the training program could look like this:

- First aid, what to do
- In case of fire
- Laboratory behavior
- Procedures and filing system
- QA/QC-routines
- Practical training

The first five steps should be identical for everybody while the practical training will be dependent of individual needs.

Quality control

Field blanks

Field blanks are used as a control for the sample handling procedures. Field blanks are used at DoM for the SO₂-sampling on bubble flasks. For the water samples two field blanks should be obtained each time the samples are collected. One of the samples is filled with distilled water at the laboratory in Gaborone before the sampling, and the other is filled with distilled water at the laboratory in Selebi Phikwe. Both field blanks must be treated exactly the same way as the normal samples.

Control samples

Control samples are used for detection of changes or deviations in the analysis methods. A control sample is a sample that is analyzed every time an ordinary sample is analyzed. It is the same sample every time and it is used as a reference. Control samples can be plotted in a control chart (see later) for easier detection of deviations.

Volumetric and gravimetric equipment

Gravimetric equipment (balances) should be calibrated and checked against a set of control weights. This should be performed regularly (i.e. once a month). The control weighing can be plotted in a control chart.

Volumetric equipment (pipettes, burettes, etc.) can be checked by weighing of measured volume of water. This should be performed for new equipment, but is probably not necessary to do more than once if the glassware is not heated.

Chemicals

Chemicals can decompose when stored or they can be of poor quality when delivered. New batches should be compared to older batches to check if the new batch has similar quality, or if the old batch have been degraded during storing. Reactivity of chemicals can vary a lot and different precautions are needed for different chemicals. Poor quality chemicals can be detected by the use of control samples.

All chemical containers should have a sticker showing when the chemicals arrived at the laboratory, when they were first opened, and by whom (Figure I 2).

	Date:	Sign:
Received:	23. jan. 96	KCL
First opened:	12. feb. 96	BM

Figure I 2: Example of a sticker showing valuable information about the chemical container.

Control Charts

A control chart is a standard way of plotting control samples to detect deviations from normal conditions. The data are plotted together with warning limits and alarm limits. If any of the data fall outside the warning limits, the samples should be controlled. If the data falls outside the alarm limits, action must be taken and the samples analyzed together with the control samples must be analyzed again. The method is based on detecting outliers by using the normal spread of the data as a basis for the warning and alarm limits. The warning limits are defined as the mean value plus/minus 2 times the standard deviation and the alarm limits as the mean value plus/minus 3 times the standard deviation.

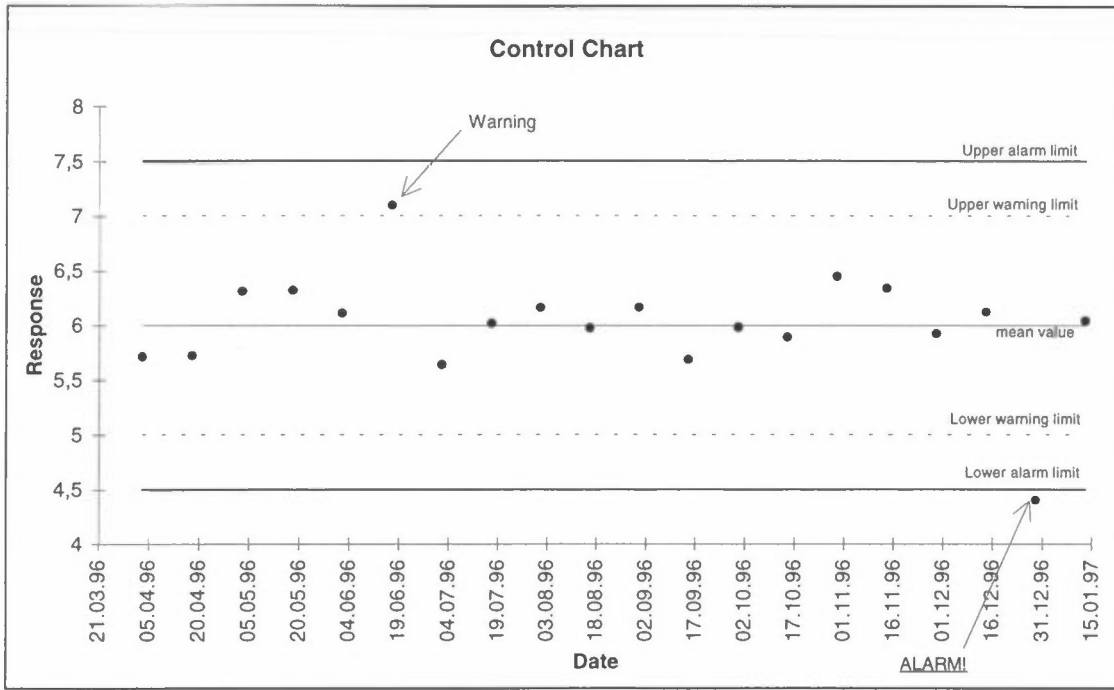

Figure 13: Example of a control chart.

Appendix J

Air Quality Monitoring and Surveillance Program – Botswana – Planning of new laboratory

Air Quality Monitoring and Surveillance Program - Botswana - Planning of new laboratory

Meeting at the chemical laboratory at the Department of Mines, Botswana
15. nov. 1996

Participants:

from DoM : C. Matala, S. M. Mosinyi, K. K. Mogami, K. C. Lenyatso,
G. Motshwane
from NILU : O. Hermansen

This notes summarizes the discussion about the space needed for a new laboratory for the Air Pollution Control Division in Gaborone. The meeting was held as part of the workshop at the Department of Mines in November 1996.

Summary

The meeting started with a brief discussion of what kind of activities to carry out in the new laboratory.

Then the needs for equipment and facilities were evaluated.

In the end, some brief sketches were made for each room in the laboratory to help quantifying the total space requirements.

The intention of the meeting was only to give an idea of the space requirements. All activities, needs and the laboratory as a whole must be discussed in detail before the actual planning of the building. Space for corridors, offices etc. was not discussed.

Needs

A great number of organic and inorganic pollutants will be analyzed. There will be a need to handle a wide range of sample types. The laboratory should be divided into a number of sections to avoid contamination and to cover the needs of different instrument types.

A list of necessary instruments is presented below:

Inorganic analysis:

- Atomic absorption
- Ion chromatograph
- UV/vis spectrophotometer
- pH meter
- Conductivity meter
- Laboratory balances

Organic analysis:

- Gas chromatographs
- Liquid chromatographs

Description of the rooms

Laboratory for inorganic analysis

The laboratory for inorganic analysis will need bench space for preparing of sample equipment (filters, bubble bottles, etc.), and for handling and preparation of samples for all kinds of analysis. The instruments should be placed on a bench with easy access to the back side of the instruments. At least one fume hood is needed and space for a water purification system is required. Cupboards for storing of a variety of glassware is also needed.

Atomic absorption instrument room

The atomic absorption instrument should be placed in a separate room to reduce heat and noise from the instrument.

The instruments should be placed on benches with easy access to the back side of the instrument.

Laboratories for organic analysis

A wide range of samples will be analyzed for organic pollutants. The levels of contamination will vary over a wide range. Two separate laboratories are needed to avoid contamination of equipment for low contaminated samples. Each laboratory need three fume hoods for preparation of filters, extraction of samples, rinsing/chemical treatment and volume reduction. The HPLC for aldehyde/ketone analysis could be placed in the laboratory for low level contaminated samples. The HPLC should be placed on a bench with easy access to the back side of the instrument.

Gas chromatograph instrument room

The gas chromatographs should be placed in a separate room because of contamination risks and the heat evolved.

The instruments should be placed on a bench with easy access to the back side of the instruments.

Weighing room

The weighing room should be a separate room with full control of temperature and humidity. Special equipment is needed to keep the dust amount at a minimum level (e.g. electrostatic filters). The weighing room needs space for storing of filters to be conditioned before weighing.

Sample storage room

The sample storage room should be a cold place for storing incoming samples and old samples in case of re-analysis.

Storage room for chemicals

The room for storing of chemicals must be separate from the labs. A refrigerator is needed for storing reactive chemicals.

Room for ovens and noisy equipment

Ovens and noisy equipment should be placed in a separate room to reduce problems with temperature control in the laboratories and to increase the working environment.

Gas cylinders

Gas cylinders should be stored and connected to the gas lines in a separate room with good ventilation. Entrance to the room should be from the outside. The room should be constructed to minimize the damages and hazards to the rest of the building in case of explosions.

Reception / sample registration

A place is needed for the registration of all incoming samples. This should be located close to the entrance of the laboratory.

Extra instrument room

The laboratory should be able to cover future needs. An extra instrument room with easy access to gas lines and electrical connections should be built. This room could be used as a storage room or as an office needed for laboratory purposes. The temperature regulation should have enough capacity for heat producing instruments.

Space requirements

Sketches for each room will be found in the appendices. Space requirements for each room and for the whole laboratory are summarized in the Table below.

Rooms:	Size	
Laboratory for inorganic analysis	13.2 x 8.0 m ²	105.6 m ²
Laboratory for organic analysis, low level	6.0 x 8.5 m ²	51.0 m ²
Laboratory for organic analysis, high level	6.0 x 4.5 m ²	27.0 m ²
Instrument room, AAS	5.5 x 5.0 m ²	27.5 m ²
Instrument room, gas chromatographs	5.5 x 5.0 m ²	27.5 m ²
Weighing room	3.5 x 3.5 m ²	12.3 m ²
Sample storage room	3.0 x 4.0 m ²	12.0 m ²
Storage room for chemicals	3.0 x 4.0 m ²	12.0 m ²
Storage room, general storage	3.0 x 4.0 m ²	12.0 m ²
Room for ovens and noisy equipment	3.0 x 4.0 m ²	12.0 m ²
Room for gas cylinders	3.0 x 2.0 m ²	6.0 m ²
Reception/sample registration	4.0 x 4.0 m ²	16.0 m ²
Extra instrument room	3.0 x 4.0 m ²	12.0 m ²
Total space		332.9 m ²

INORGANIC LABORATORY

13,2 x 8 m²

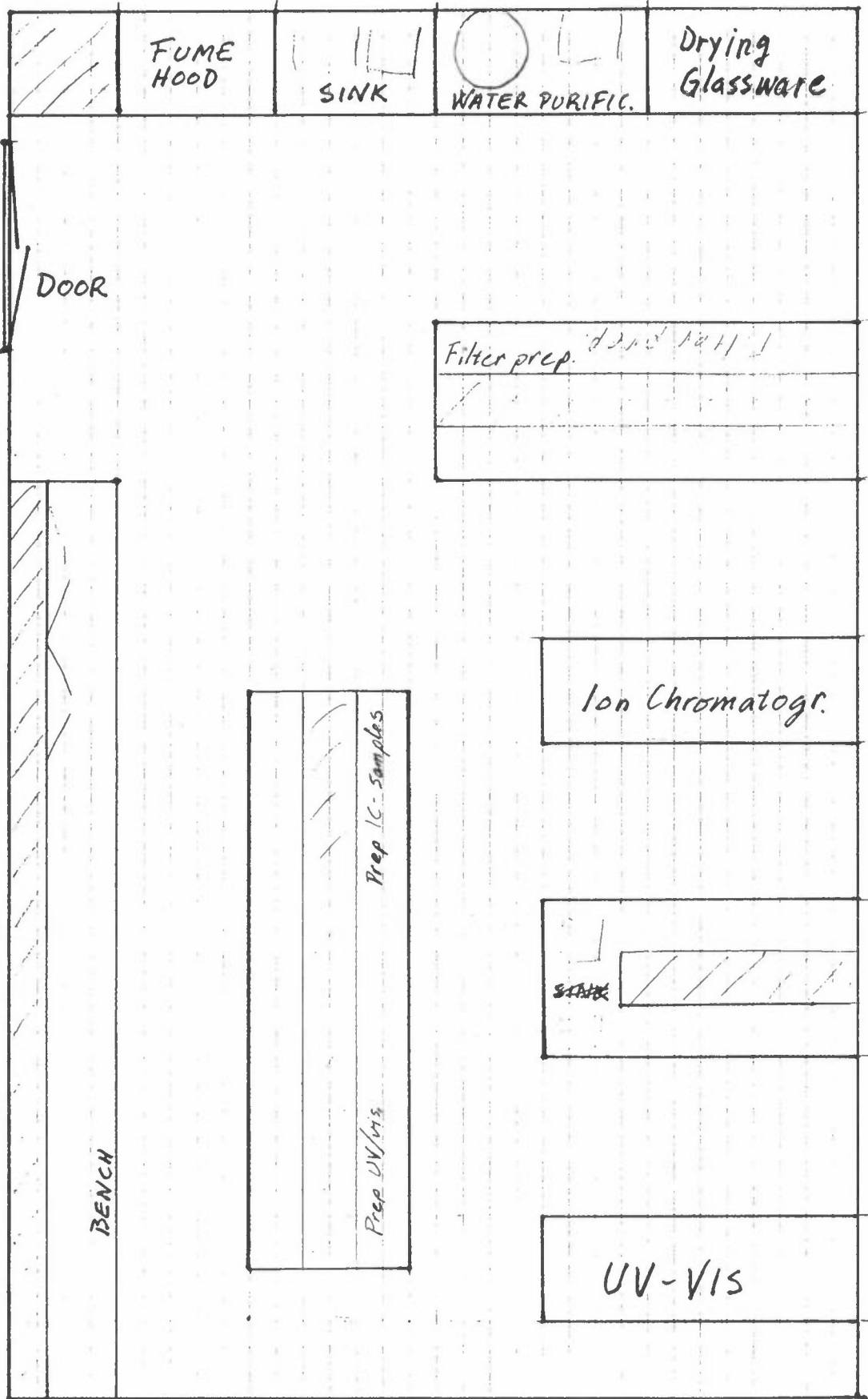

LABORATORIES FOR ORGANIC ANALYSIS

LOW LEVEL
POLLUTION

6 x 8,5 m²

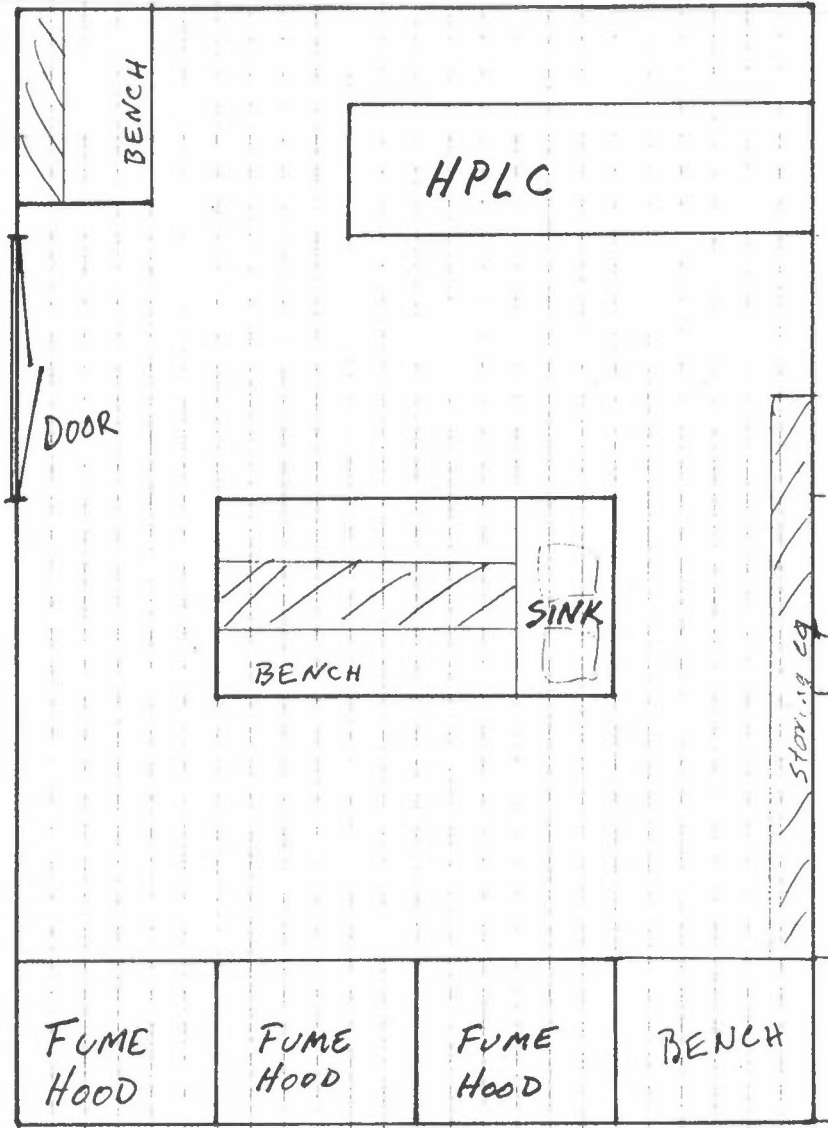

HIGH LEVEL
POLLUTION

6 x 4,5 m³

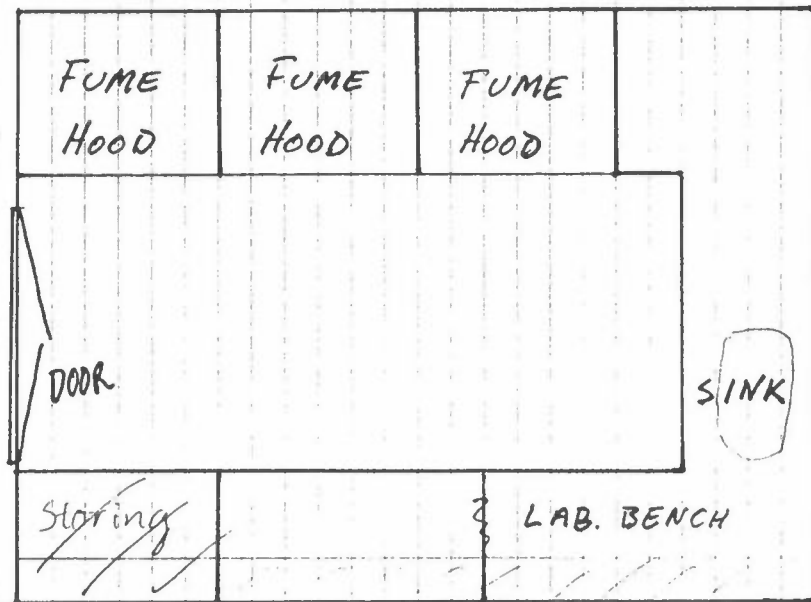

INSTRUMENT ROOM ATOMIC ABSORPTION

5,5 x 5 m³

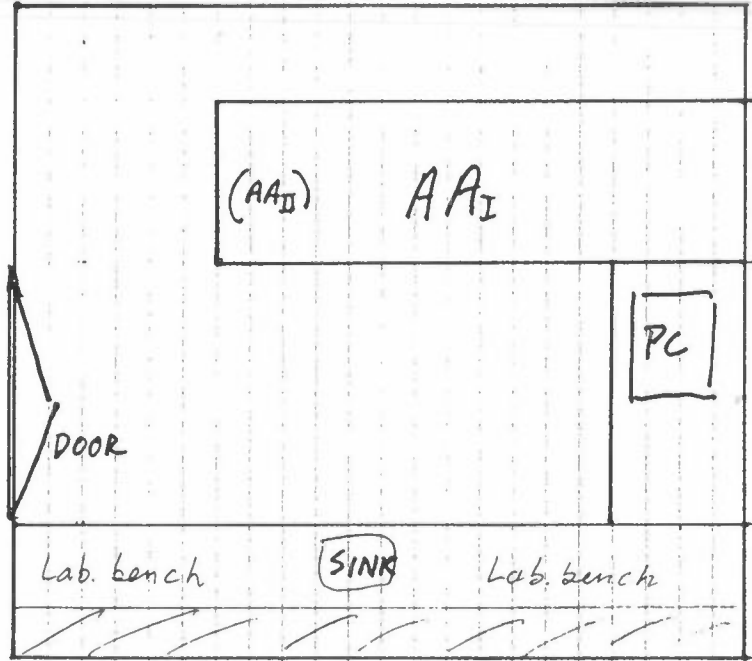

INSTRUMENT ROOM GAS CHROMATOGRAPHS

5,5 x 5 m³

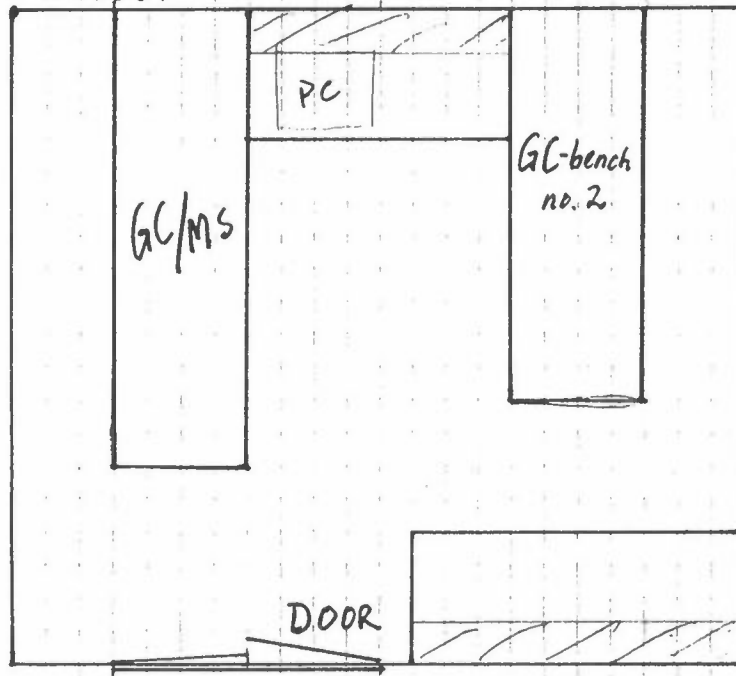

BALANCE ROOM

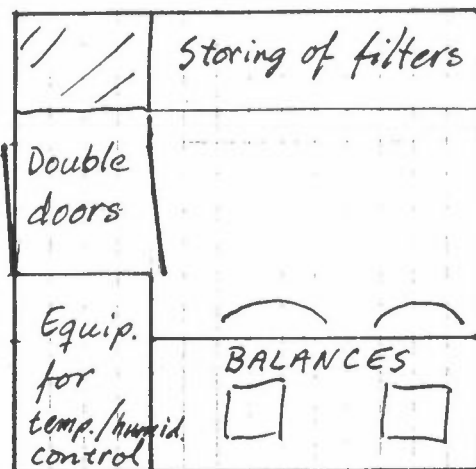
3,5 x 3,5 m²

SAMPLE STORAGE ROOM

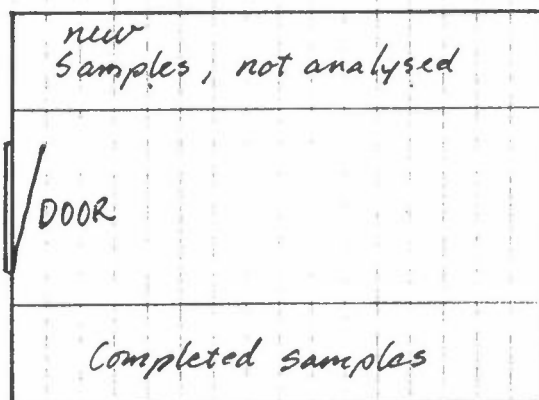
3 x 4 m²

STORAGE ROOM FOR CHEMICALS

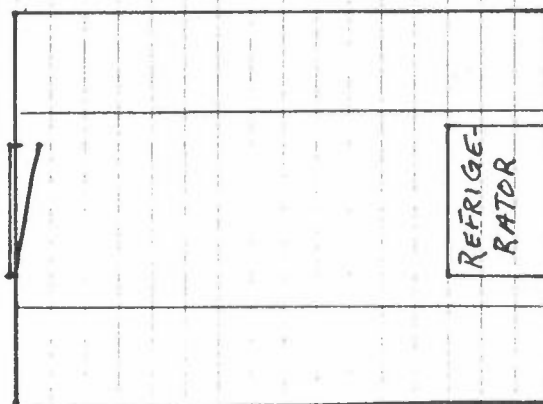
3 x 4 m²

STORAGE ROOM *general storage*

3 x 4 m²

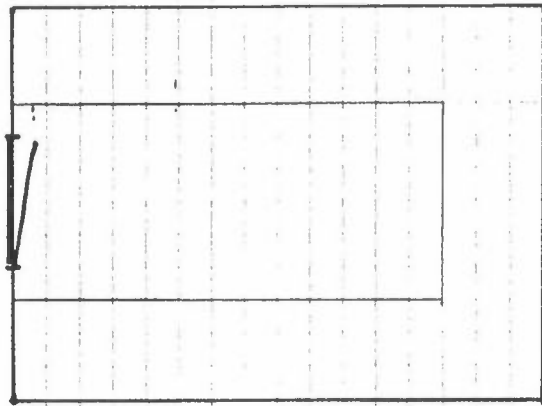

ROOM FOR OVENS AND NOISY EQUIPMENT

3 x 4 m²

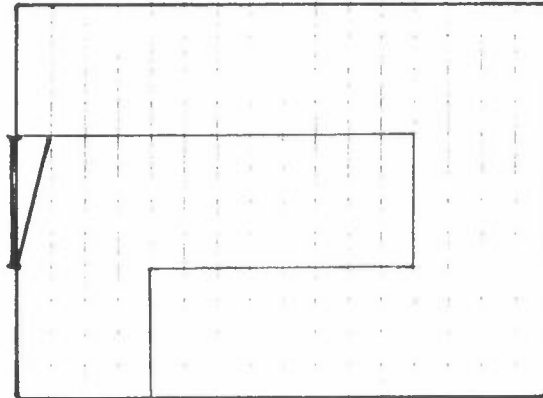

ROOM FOR GAS CYLINDERS

3 x 2 m²

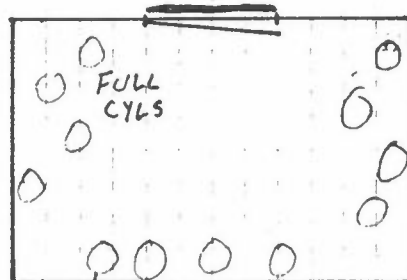

EMPTY CYLS.

CYLS. CONNECTED TO GAS LINES

ENTRANCE FROM OUTSIDE

RECEPTION / SAMPLE REGISTRATION

4 x 4 m²

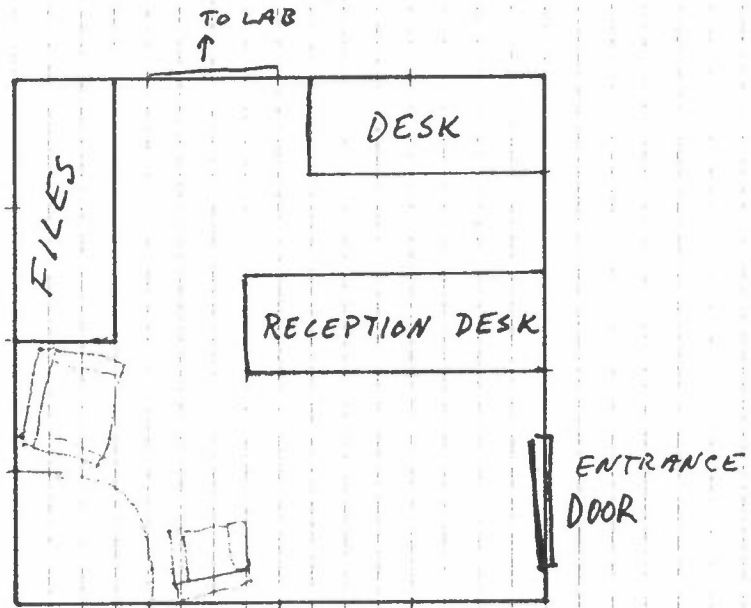

EXTRA INSTRUMENT ROOM (X-ray instr. or HRMS...-etc)

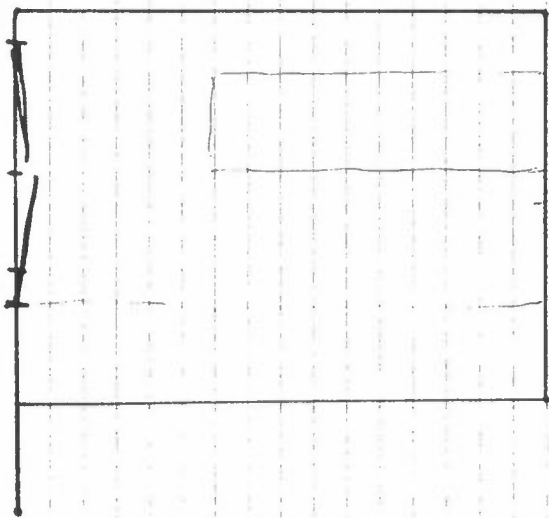

Appendix K

**Visit at the water laboratory,
Department of Water Affairs
8 November 1996**

Visit at the water laboratory, Department of Water Affairs 8 November 1996

Participants

from Department of water affairs:	Mrs O. M. Serumole
from Department of Mines:	C. M. Matala
	K. K. Mogami
from NILU:	O. Hermansen

During the seminar held at the President Hotel in Gaborone, NILUs laboratory expert was invited to visit the water laboratory at the Department for Water Affairs.

The laboratory is placed in a new building with all facilities required to run a modern laboratory for water analysis.

About 2000 samples are analyzed per year, mostly inorganic chemical analysis and some bacterial analysis.

The activities in the laboratory are fully financed by the state and everybody can deliver samples to get them analyzed at no charge.

A separate instrument room is used for atomic absorption spectrophotometry (Varian SpactrAA 10 plus) with graphite oven (GTA 96 plus). It is mainly being used for Ca and Mg analysis. Some work has been performed with the analysis of Hg.

Another instrument room is used for chromatographic equipment. An ion chromatograph (Dionex DX-100 with paper roll integrator) is used for anion analysis. A new GC/FID/ECD (Shimadzu with PC-integration system) is not yet in use, but plans are to use it for pesticide analysis.

A UV spectrometer (Shimadzu 1601) is used for spectrophotometric analysis.

Water is purified by a water distillation system with good capacity and equipment for deionising water (Millipore).

Most of the laboratory is placed in one room with plenty of bench space, fume hoods and sinks.

A separate room is used for storing of chemicals.

Appendix L

What, How, Who and When for the chemical laboratory

What	How	Who	Completion date
Safety in the lab	• fill the first aid box and learn how to use it	SMM	Jan -97
	• buy safety eq. (eye wash bottles, fire blankets, shower)	SMM	Jan -97
	• learn how to use safety eq.	SMM(All)	
	• get safety data sheets		
	• get direct telephone line?, put up a sign with the emergency numbers	KCL KCL	
	• get a fire alarm?		
	• check for gas leakages	KCL	
	• get some std. information about safety in the lab	KKM OH	
Training prog. for new personnel	• full description of a training programme (as described in the QA/QC notes)		
Test grav. & vol. equipment	• Buy control weights for the balance	KCL	
	• Check/calibrate the balance	KCL	
	• Check the volumetric eq. by gravimetric control	KCL	
Establish a QA/QC system for the chemical laboratory	• design guidelines for QA/QC in the lab	OH	March -97
	• organise a filing system		March -97
	• make procedures for		
	- sample handling	KKM	Jan -97
	- method descriptions	KKM	Jan -97
	- operation and maintenance of instruments	KKM	Feb -97
	- use of volumetric and gravimetric eq.	KCL	Jan -97
	- storing/handling of chemicals	KCL	Jan -97
	- cleaning of glassware/lab. equipment	KCL	Jan -97
	- cleaning of laboratory	KCL	Jan -97
	• introduce sample forms	KCL	Dec -96
	• introduce field blanks	KCL	Jan -97
	• introduce control samples	KCL	Jan -97
• introduce the use of control charts	KCL	Feb -97	
• put stickers on chemical containers	KCL	Jan -97	
• evaluate the QA/QC system	All	March-97	
Handling of chemical waste	• is there any system for the disposal of chemical waste? Find out	KCI	Jan -97

What	How	Who	Completion date
Method development in Gaborone	• GC/MS techniques	KKM/OH	March -97
	• try out spectrophotometric techniques (EMEP-manual)	KKM/OH	March -97
	AAS-method development	KKM/OH	Jan -97
2. training visit at NILU		KCL	1998
3. training visit at NILU		#3	1999

Appendix M
Inventory list.
Gaborone Calibration Laboratory

Inventory list. Gabarone laboratory.

Parameter	Equipment in calibration laboratory
NO, NO ₂ , NO _x	Multipoint calibrator NO _x monitor Computer Zero air Traceable main calibration gas cylinder 100 ppm Calibration procedures Calibration schemes Calibration log
SO ₂	Multipoint calibrator SO ₂ monitor Computer Zero air Traceable main calibration gas cylinder 100 ppm Calibration procedures Calibration schemes Calibration log
CO	CO monitor Computer Zero air Traceable main calibration gas cylinder 50 ppm Calibration procedures Calibration schemes Calibration log
Ozone	Ozone photometer Computer Zero air Calibration procedures Calibration schemes Calibration log
HC	HC monitor Computer Traceable main calibration gases Zero air Calibration procedures Calibration schemes Calibration log

Parameter	Equipment in calibration laboratory
Bubbler	Wet gas meter Calibration procedures Calibration schemes Calibration log
Meteorology	Spare parts for sensors and computing units
High Vol.	Traceable flow calibration unit

Appendix N

Inventory list.
Equipment at site

Inventory list. Equipment at site

Parameter	Equipment at site
NO, NO ₂ , NO _x	NO _x monitor Computer Zero air Calibration gas cylinder .800 ppm Calibration procedures Calibration schemes Calibration log
SO ₂	SO ₂ monitor Computer Zero air Calibration gas cylinder .800 ppm Calibration procedures Calibration schemes Calibration log
CO	CO monitor Computer Zero air Calibration gas cylinder 50 ppm Calibration procedures Calibration schemes Calibration log
Ozone	Ozone analyzer with zero/span Computer Calibration procedures Calibration schemes Calibration log
HC	HC monitor Computer Calibration gases Zero air Calibration procedures Calibration schemes Calibration log

Bubbler	Handling procedures Handling log
Meteorology	Handling procedures Handling log
High Vol.	Handling procedures Handling log

Appendix O

Description of procedure for calibration of Monitor Lab Nitrogen Oxides Analyzer, Model 9841(A)

Description of procedure for calibration of Monitor Lab Nitrogen Oxides Analyzer, Model 9841(A)

Short description of the equipment

The instrument used is a Monitor Labs Nitrogen Oxides Analyzer Model 9841 (A). The concept of the measuring method is described in detail in the Operator Manual, which is at the monitoring station. A sketch of the front panel of the instrument is shown in Figure G1.

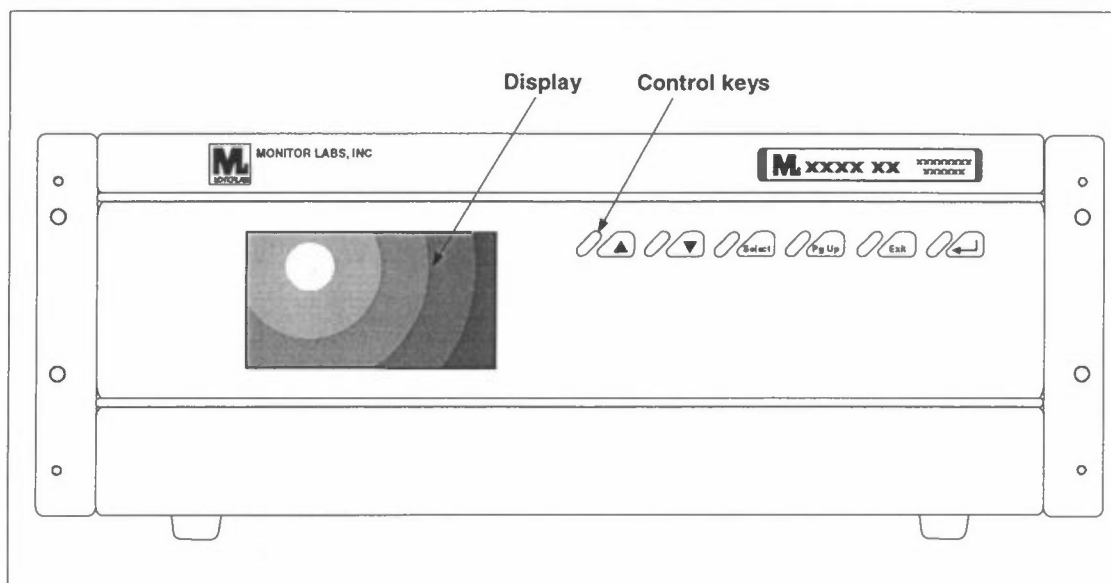

Figure G1: Front panel of a Monitor Labs Nitrogen Oxides Analyser Model 9841 (A).

Air is drawn through a tube from an intake that is mounted either through the wall or through the roof of the monitoring station. Inside of the monitoring station the tube is connected to the intake tube at the instrument by use of a short rubber tube. If two instruments use the same intake a Y-part is installed in the junction. One part of the Y is connected to the tube from the intake while the two other parts are connected to the respective instruments intake tubes. During calibration it is important that the open end of the Y-part that is disconnected is tightened to prevent the other instrument to draw air from inside the monitoring shelter instead of outdoor air.

The measurement signal from the instrument is transferred to and saved in a logger (see Figure G2). The logger have four inlets in the front of the instrument with descending numbers. Inlet number 1 logs the NO-signal from the instrument, while inlet number 2 logs the NO_x-signal.

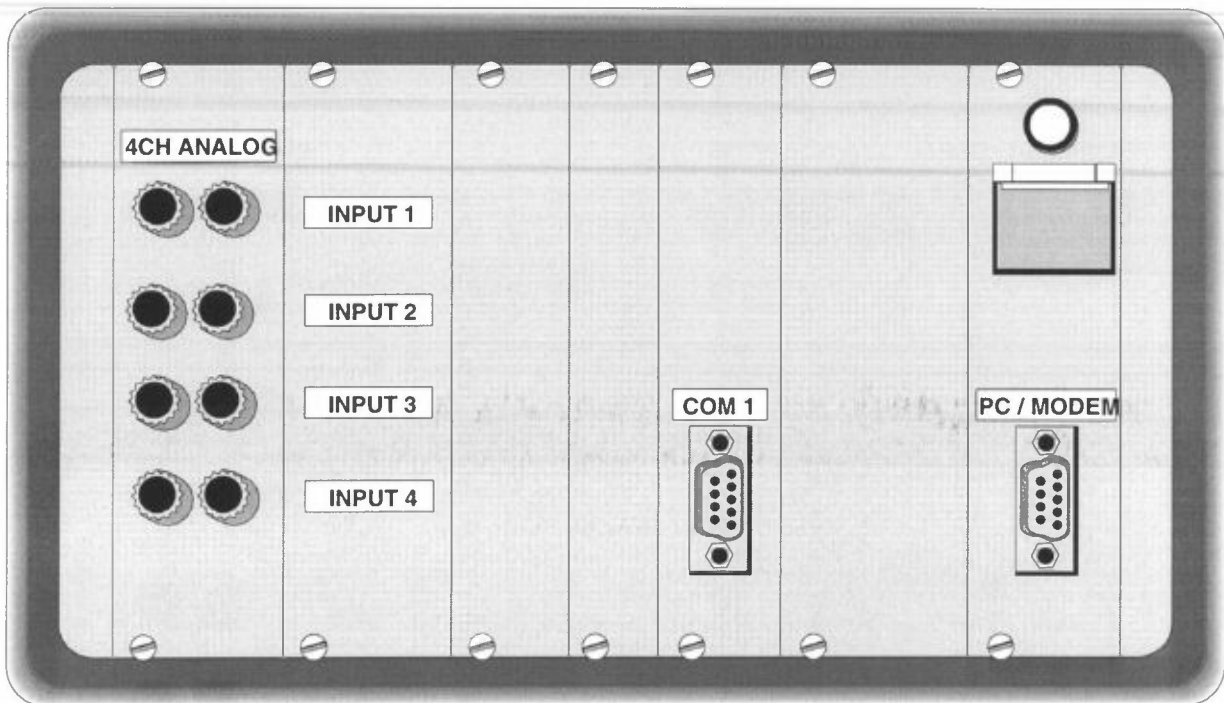

Figure G2: Front panel of the data logger.

The logger is connected to a modem which makes the measured data transferrable to NILU by telephone lines.

The following equipment are available at the station for additional help in the calibration process of the instrument:

- Zeroair generator
- A gas bottle with calibration gas
- A multimeter
- A form to be filled out for routine control of the monitor.

To measure the signal from the instrument the multimeter must be connected to the inlet in front of the logger. It is necessary to alternate between input 1 and 2 to measure the NO- and the NO_x-signals, respectively. **NOTE!** Do not short-circuit the banana plugs!

A **Druva** type regulator is mounted to the gas bottles. Figure G3 show a sketch of this regulator. A Y-part is connected to the outlet, which is connected to a rotameter (flowmeter). The rotameter is installed only to secure that the gas bottle delivers more gas than the instrument needs. Hence, it works as a spillway. The instrument should be connected to *the idle end* of the Y-part and **not** to the top of the rotameter.

The instrument is provided with a display and six buttons, see Figure G1. The buttons are used to display the different Menu-pages in the monitoring display. The menu-system is designed with a tree-structure.

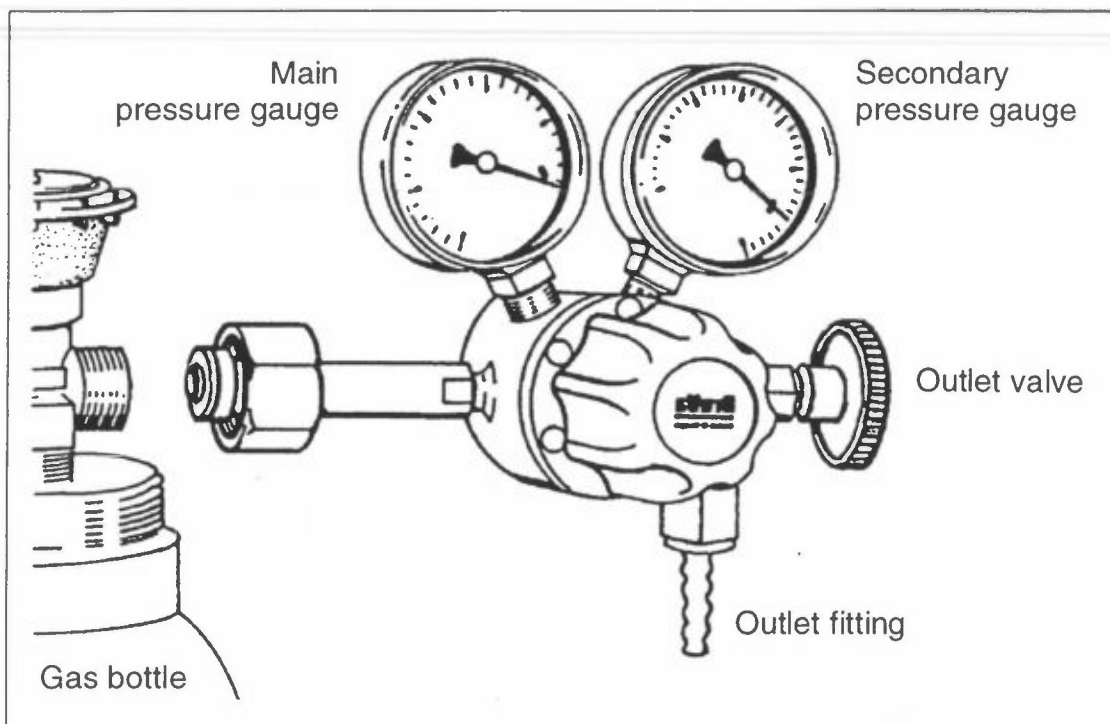

Figure G3: Drawing of the regulator of type Druva 670-01 SS.

The different functions of the buttons are:

ARROW UP/ARROW DOWN	: Moves the cursor up and down on the menu
SELECT	: Selects or moves to a selected submenu
PG UP	: Returns to the last menu page
EXIT	: Returns to the main menu/regret button
RETURN	: To confirm a change.
	Is not to be used by the local site responsible person!!

NOTE! The return button is not to be used by the station keeper!

Calibration procedure

1. Write the time and date for start-up of the calibration in the cells **Date** and **Start time** in the calibration form.
2. Turn on the multimeter by switching the switch to V=.
3. Check that the multimeter is connected to inlet number 1 (denoted NO) at the front of the logger (**NOTE!** Red to red and black to black). Do no short-circuit the banana plugs!!
4. Turn the **POWER** on (and if necessary, the **UV LAMP**) at the zeroair generator which is on the bench.
5. Put a finger in front of the **ZERO AIR OUTLET** at the zeroair generator to check that the bullet in the rotameter floats to reach the top of the scale. Adjust if necessary using the valve in the front.
6. Loosen the tube to the instrument at the junction and mount it to the **ZERO AIR OUTLET** at the zeroair generator. If the tube is connected to a Y-part, plug the open end of the Y-part. The valve denoted **AIR FLOW** has to be **adjusted** so that the bullet in the flowmeter can float freely near the top.
7. Wait for 10 to 15 minutes. When the multimeter value stabilizes, the value should be written in the cell **Zeroair - NO - Voltmeter**. Also write down the NO-value from the display in the cell **Zeroair - NO - Instrument**. If the display does not show NO/NO_x-values, press the **EXIT**-button at the instrument.
8. Swap the multimeter to input number 2 (marked NO_x in front of the logger) and write down the measured value in the cell **Zeroair - NO_x - Voltmeter**. Also write down the NO_x-value from the display in the cell **Zeroair - NO_x-Instrument**.
9. Loosen the tube going to the instrument from the **ZERO AIR OUTLET** on the zeroair generator.
10. Turn **POWER** off on the zeroair generator.
11. Swap the multimeter wires back to inlet number 1 (denoted NO in front of the logger).
12. Turn up the main tap at the top of the gas bottle containing NO calibration gas.
13. Turn the large black **adjustment nut** at the regulator inwards (clockwise) until the working manometer (the left) shows a value between 1 and 5 bar.

14. Put a finger in front of the outlet at the Y-part and carefully turn the outlet valve until the bullet in the rotameter floats to the top of the scale.
15. The tube going to the instrument should be mounted to the outlet at the Y-part of the regulator. **Adjust the** outlet-valve so the bullet in the rotameter floats freely at the top of the scale.
16. Wait for 10 to 15 minutes. When the multimeter value stabilizes the value should be written in the cell **Gas - NO - Voltmeter**. Also write down the NO-value from the display in the cell **Gas - NO - Instrument**.
17. Swap the wires from the multimeter to inlet number 2 (marked NO_x in front of the logger). Read the value on the multimeter and write the value from the display in the cell **Gas - NO_x - Instrument** in the cell **Gas - NO_x - Voltmeter**. Also write down the NO_x value in the cell.
18. Write down the value of the content manometer (the right) at the gas bottle in the cell **Gas - Bottle pressure**.
19. Loosen the intake tube from the Y-part of the regulator and mount it to the tube from the intake.
20. Tighten the outlet valve at the regulator.
21. Tighten the **adjustment nut** outwards until it runs freely in the threads.
22. Tighten the main tap on the top of the gas bottle.
23. Choose **SELECT** at the instrument. Then choose **INSTRUMENT STATUS** using the arrow buttons. Choose **SELECT**. Write down the **GAS FLOW** and the **GAS PRESSURE** values in the respective cells in the table **Instrument status** in the form. Choose **EXIT**.
24. Choose **SELECT**. Then choose **SYSTEM TEMPERATURES** using the arrows. Choose **SELECT**. Write down the six temperatures in their respective cells in the table **System temp.** in the form. Choose **EXIT**.
25. Write down the end time for the calibration in the cell **Stop time**. Other information/data/comments should be written in the cell **Notes**. Additional notes can be written on the back of the form.
26. Sign in the rubric **Signature**.

Check list

Before leaving the monitoring station check (**REMEMBER** to put a mark in the calibration form):

- | |
|--|
| <ol style="list-style-type: none">1. The tube to the instrument is connected to the tube from the intake.2. The gas bottle is secured.3. The multimeter is switched off. |
|--|

NILU should be contacted by telephone if:

1. The alteration on the multimeter changes more than 10% from one week to the next when performing calibration with the gas bottle.
2. The **GAS PRESSURE** exceeds 200 torr.
3. Errors messages are displayed in the instrument's display.
4. The station holder have questions.

Then contact Rolf Dreiem, Nils E. Ladegård, Arild Rode or Leif Marsteen on telephone:

 +47 63 89 80 00 (8 a.m. to 4 p.m.)
--

Appendix P

Selected air quality data from Gaborone

Selected air quality data from Garobone

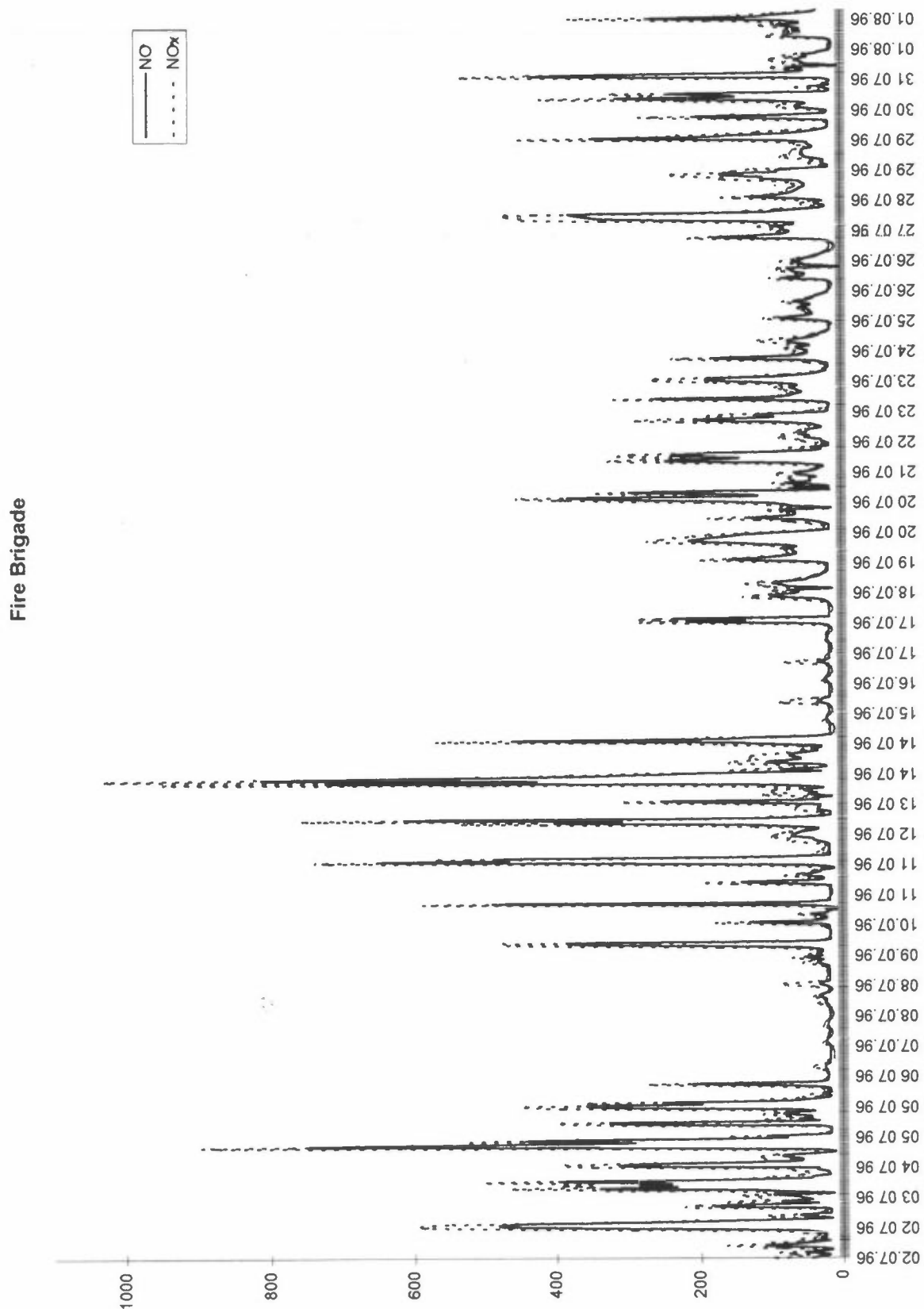

Fire Brigade

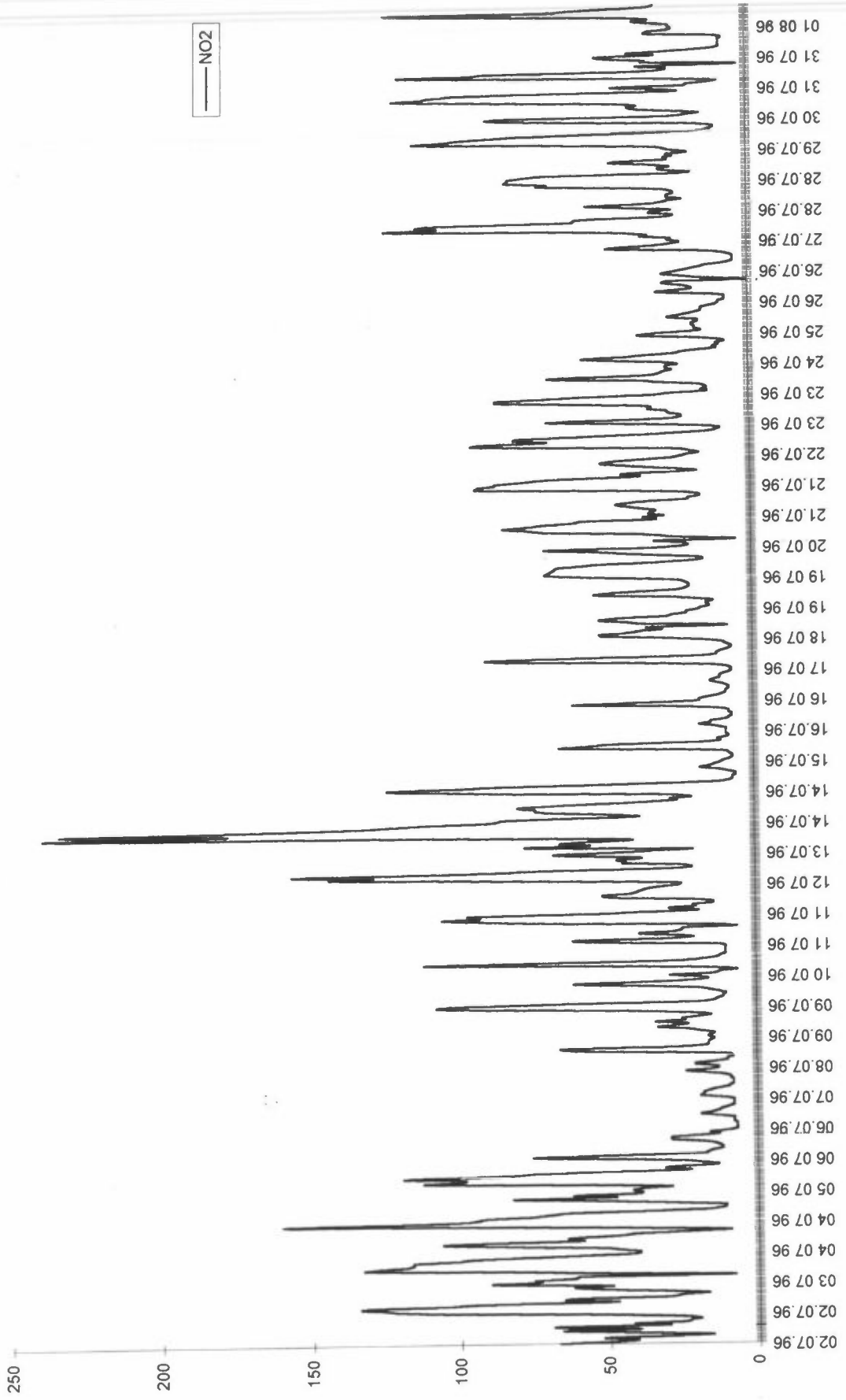

Fire Brigade

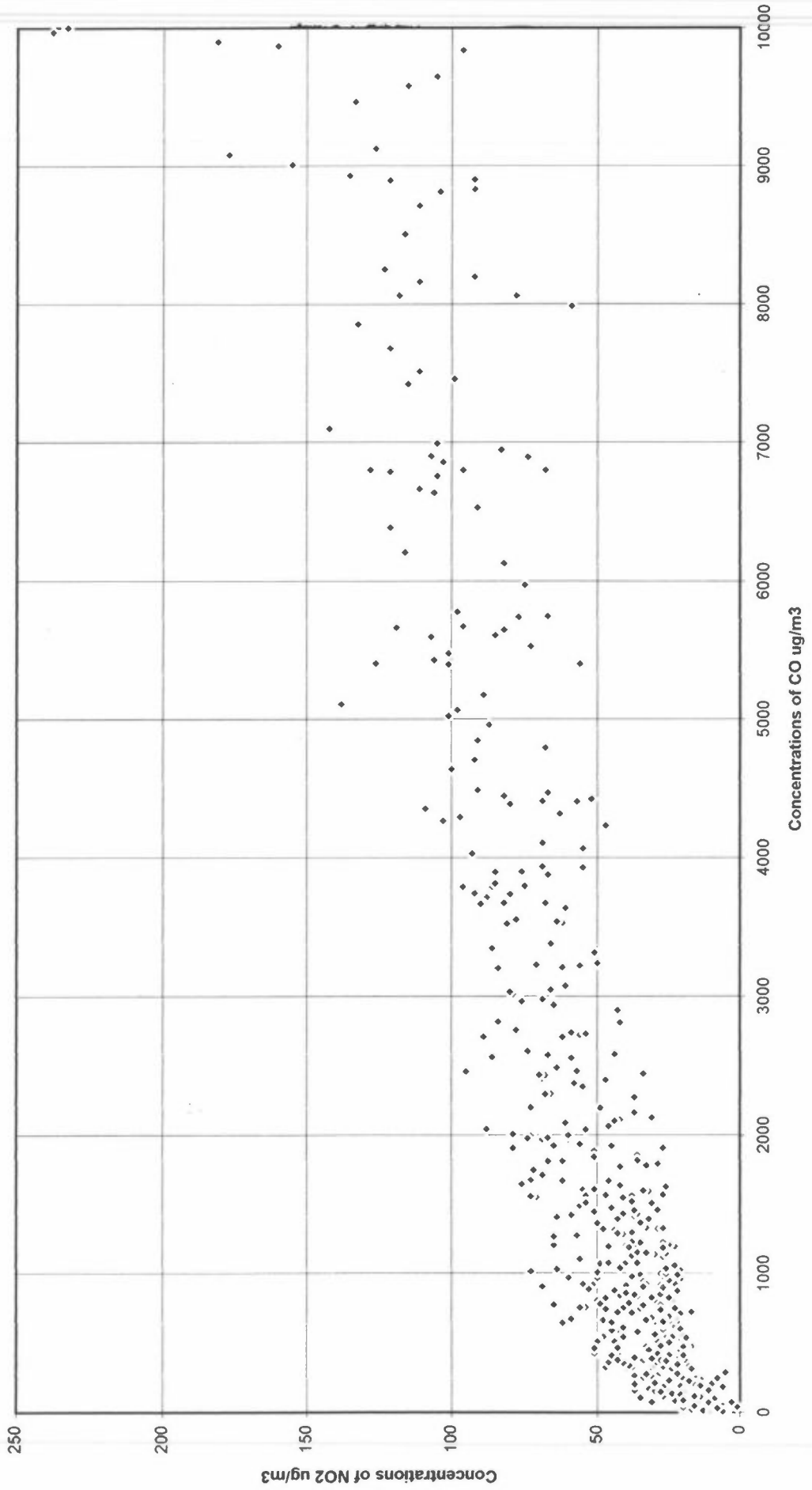

Pollutants Measured at Civic Center on 24/7/96

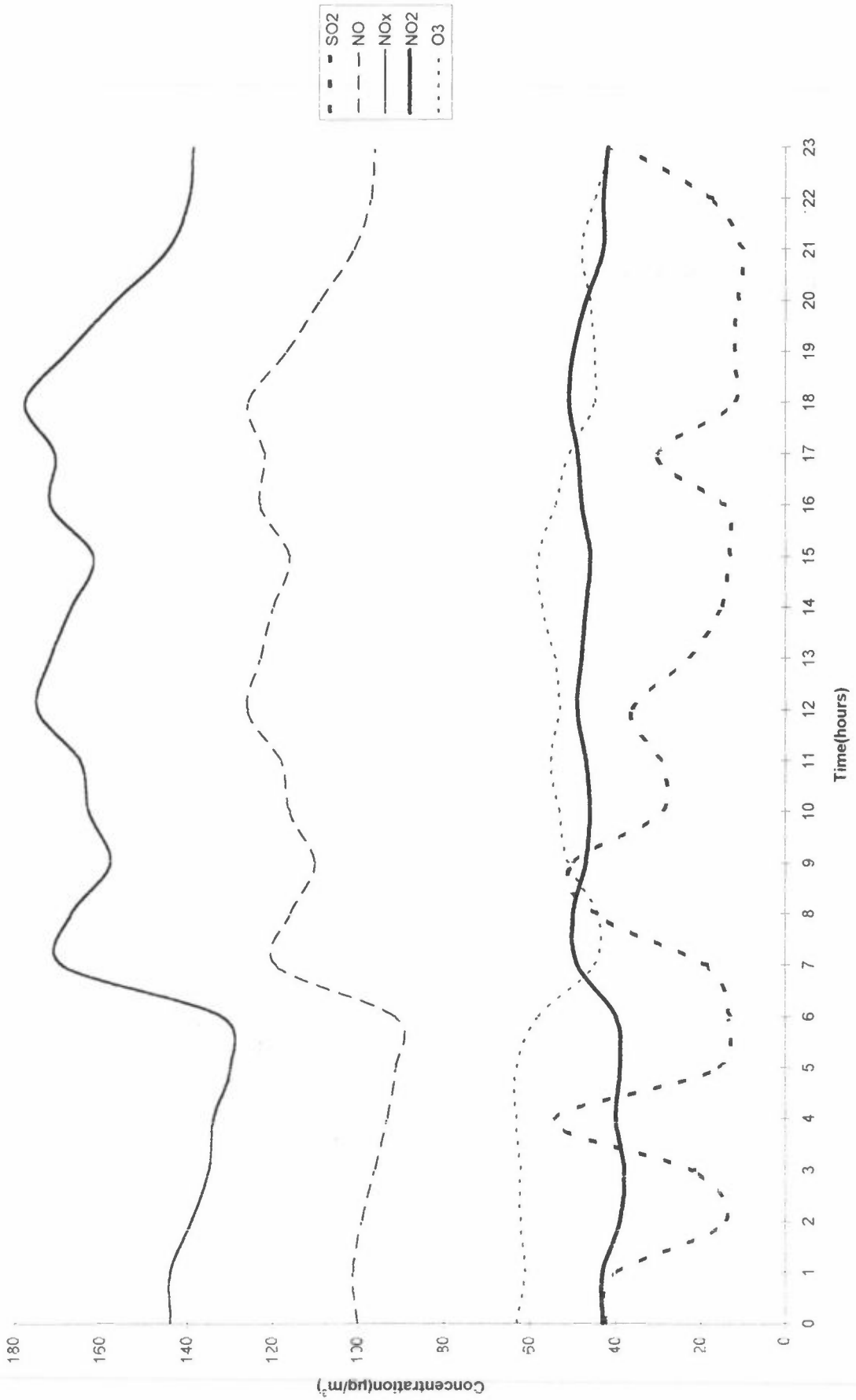

Pollutants Measured at Civic Center on 17/7/96

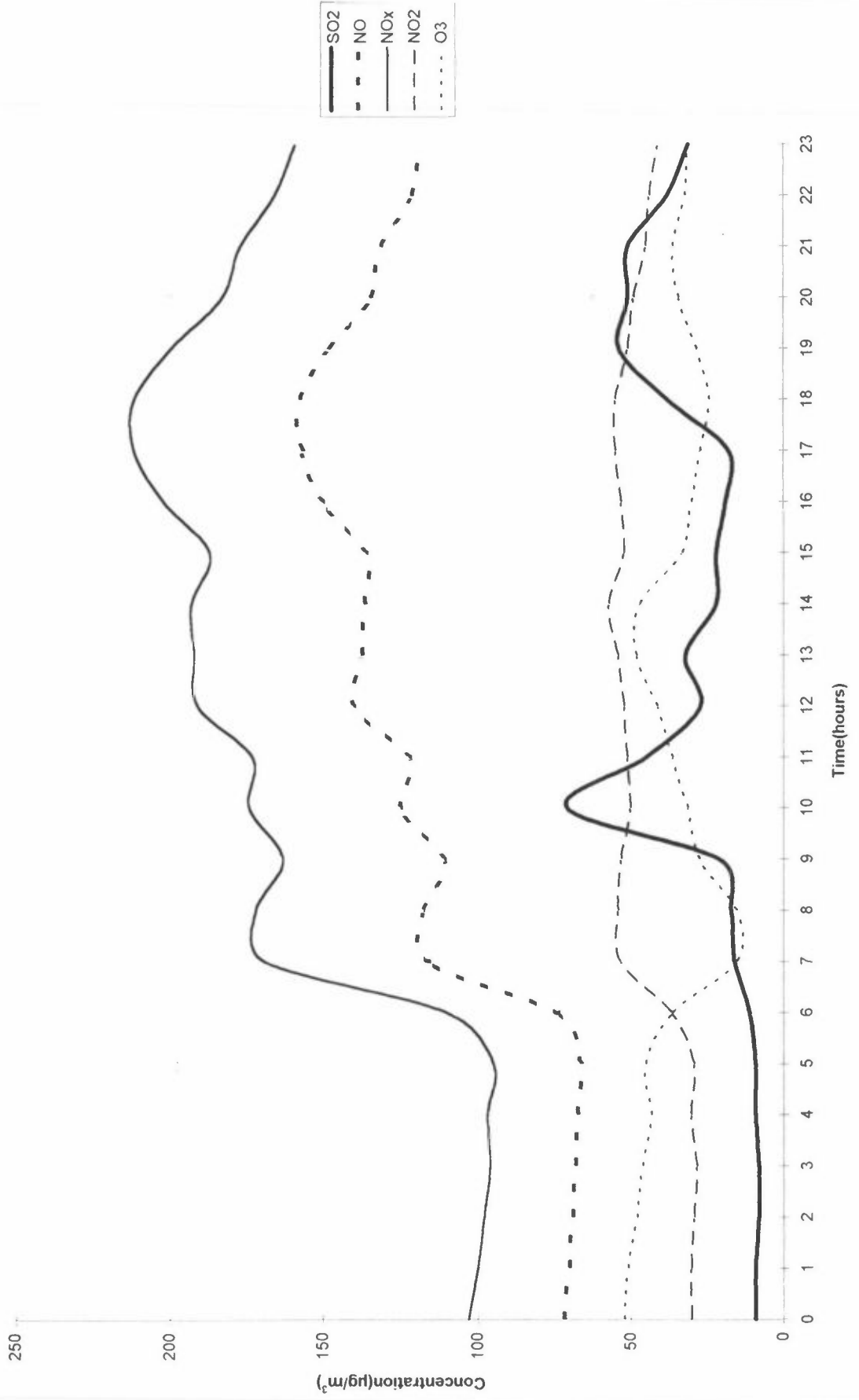

Pollutants Measured at Civic Center on 6/7/96

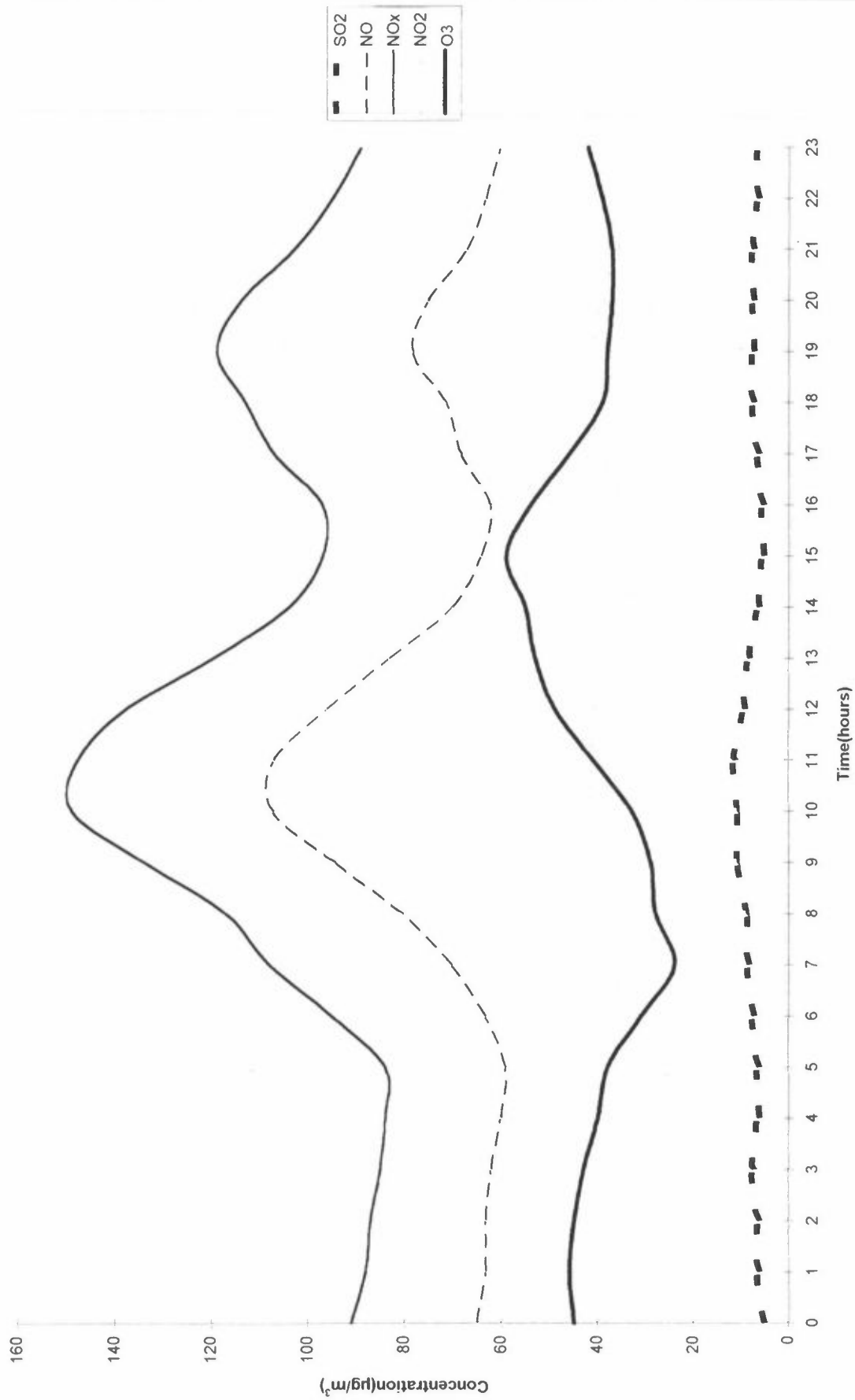

Pollutants Measured at Civic Center on 3/7/96

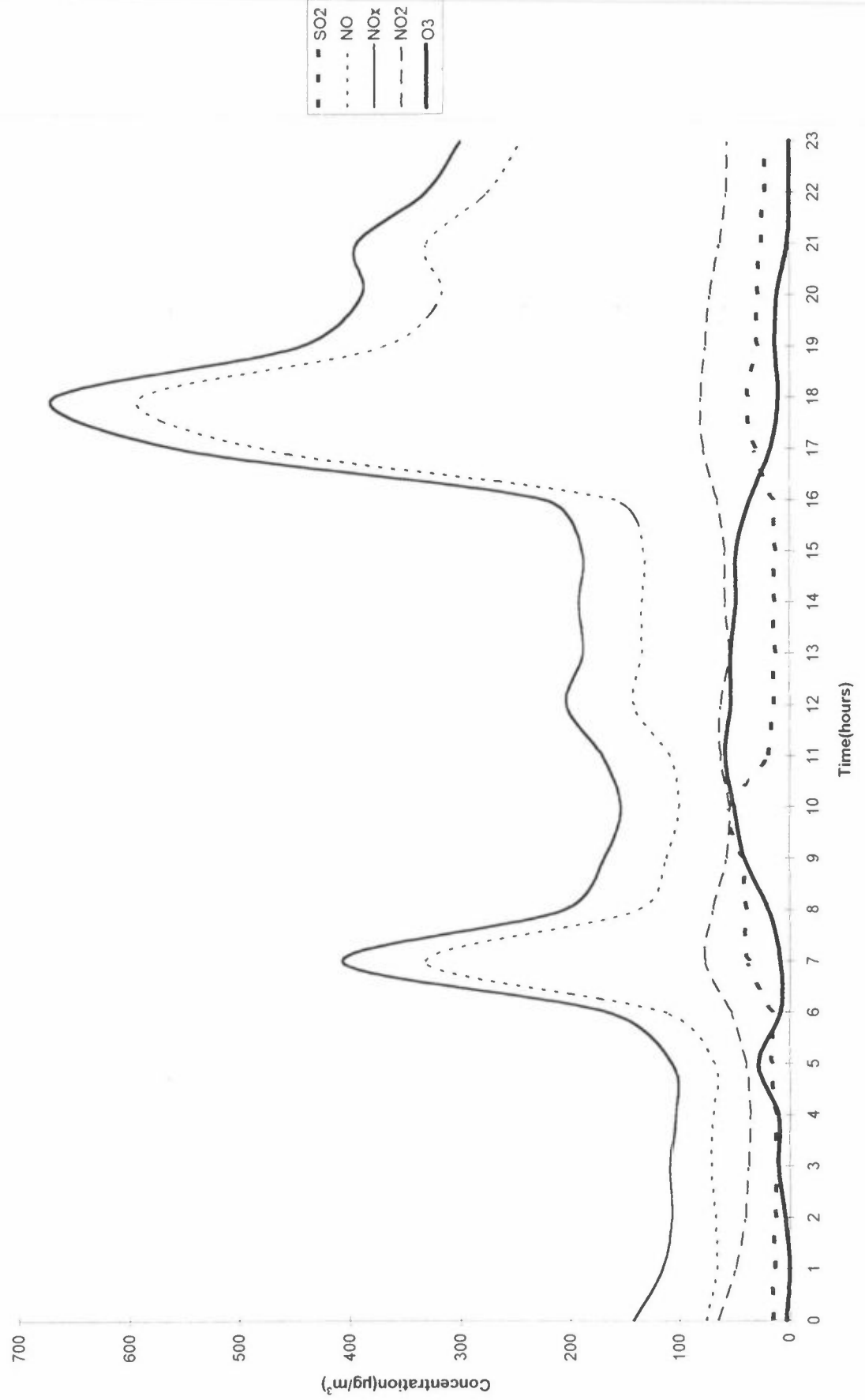

Pollutants Measured at Civic Center on 2/7/96

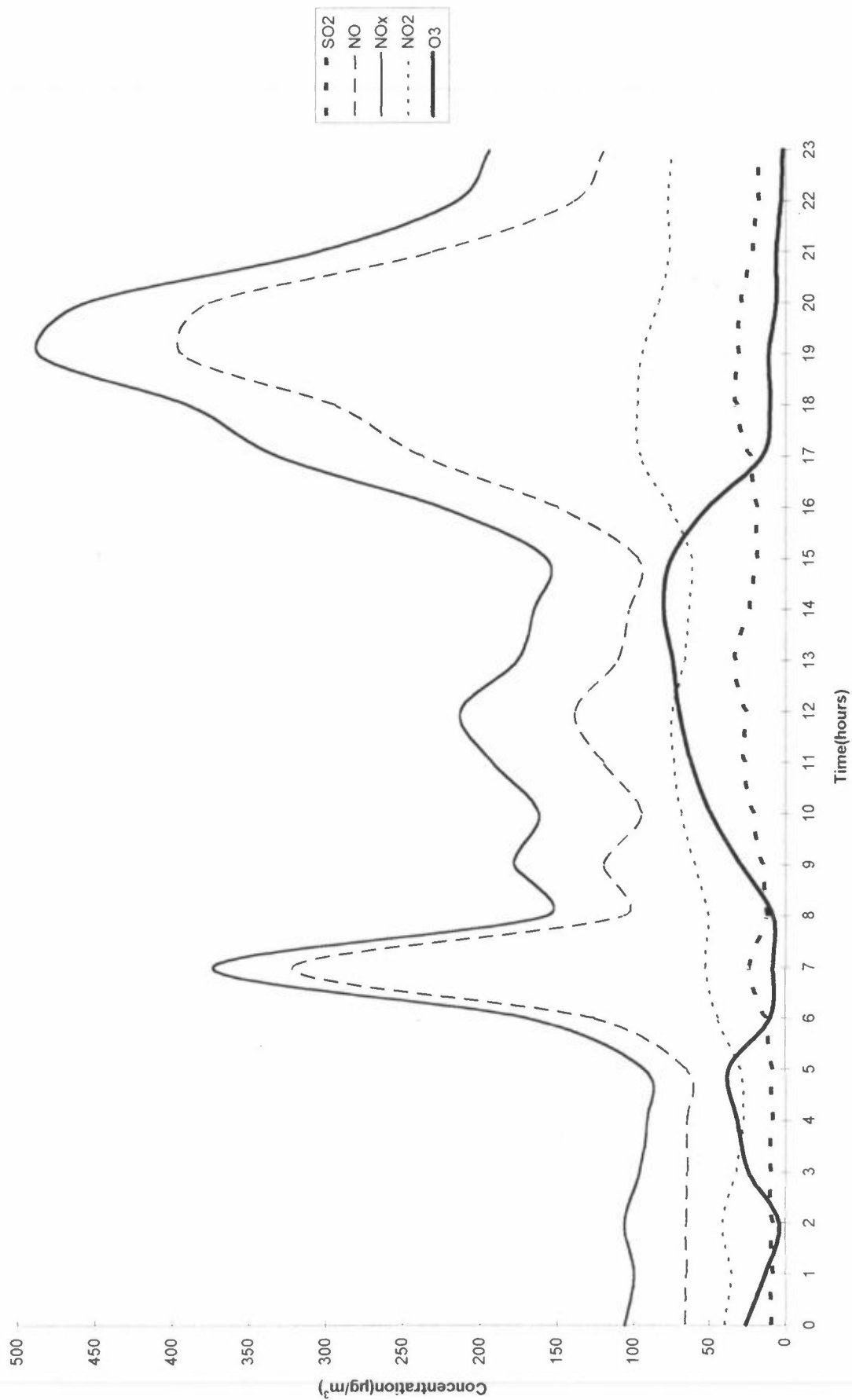

Appendix Q

Selected air quality data from Serowe

Selected air quality data from Serowe

AIR POLLUTION REPORT



DEPARTEMENT OF MINES : SEROWE STATION

AMBIENT CO CONCENTRATION

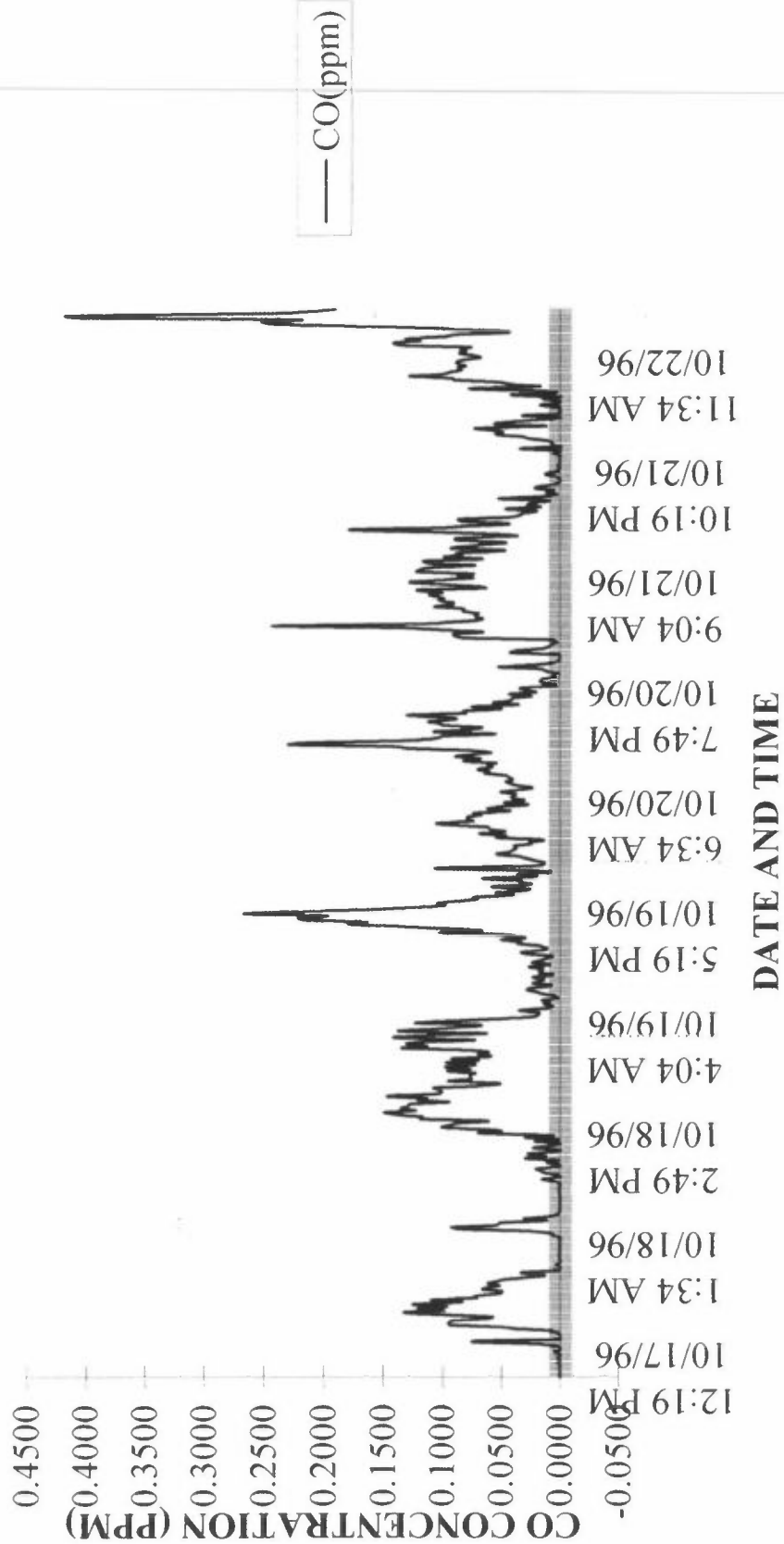

AMBIET NOx CONCENTRATION

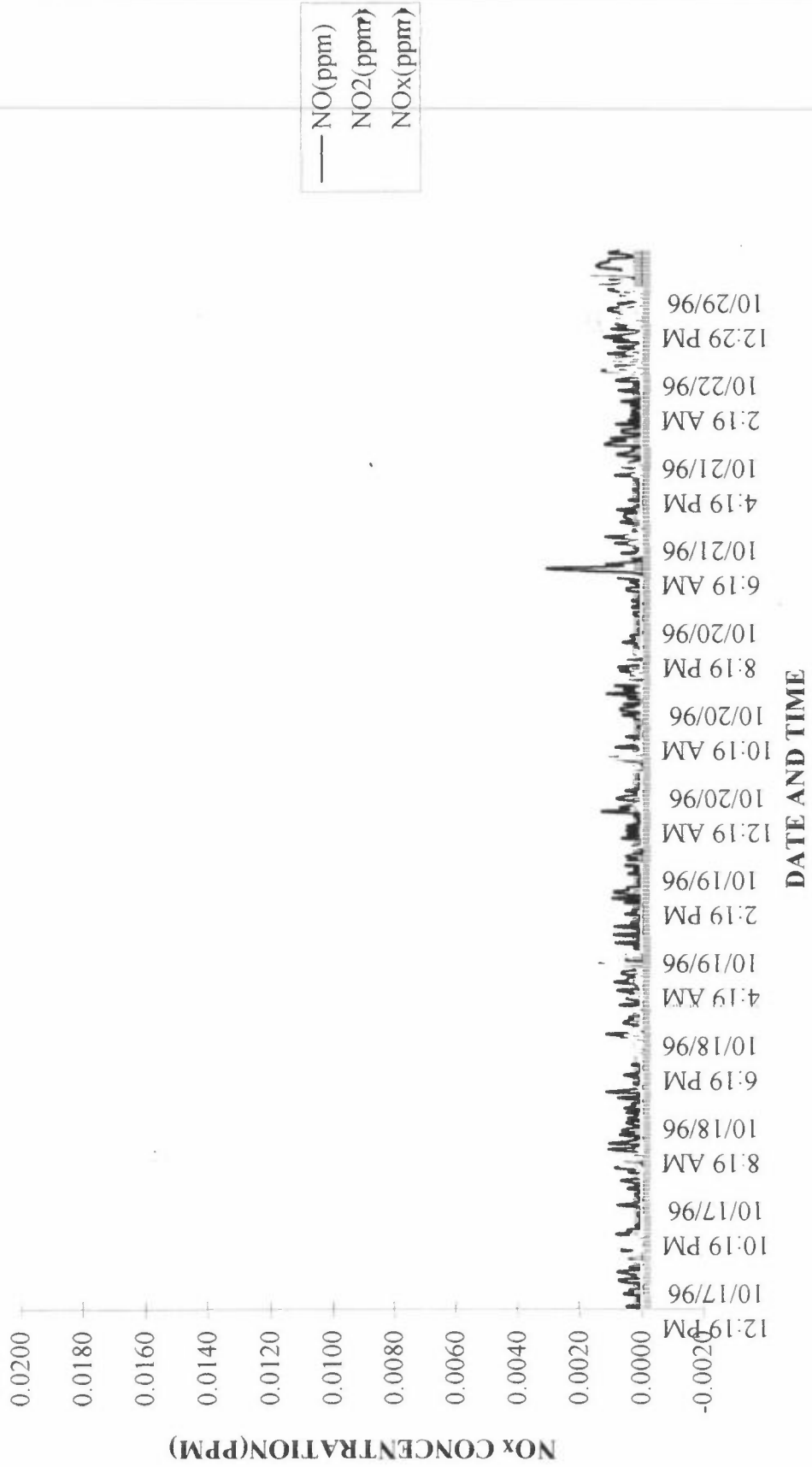

AMBIENT SO₂ CONCENTRATION

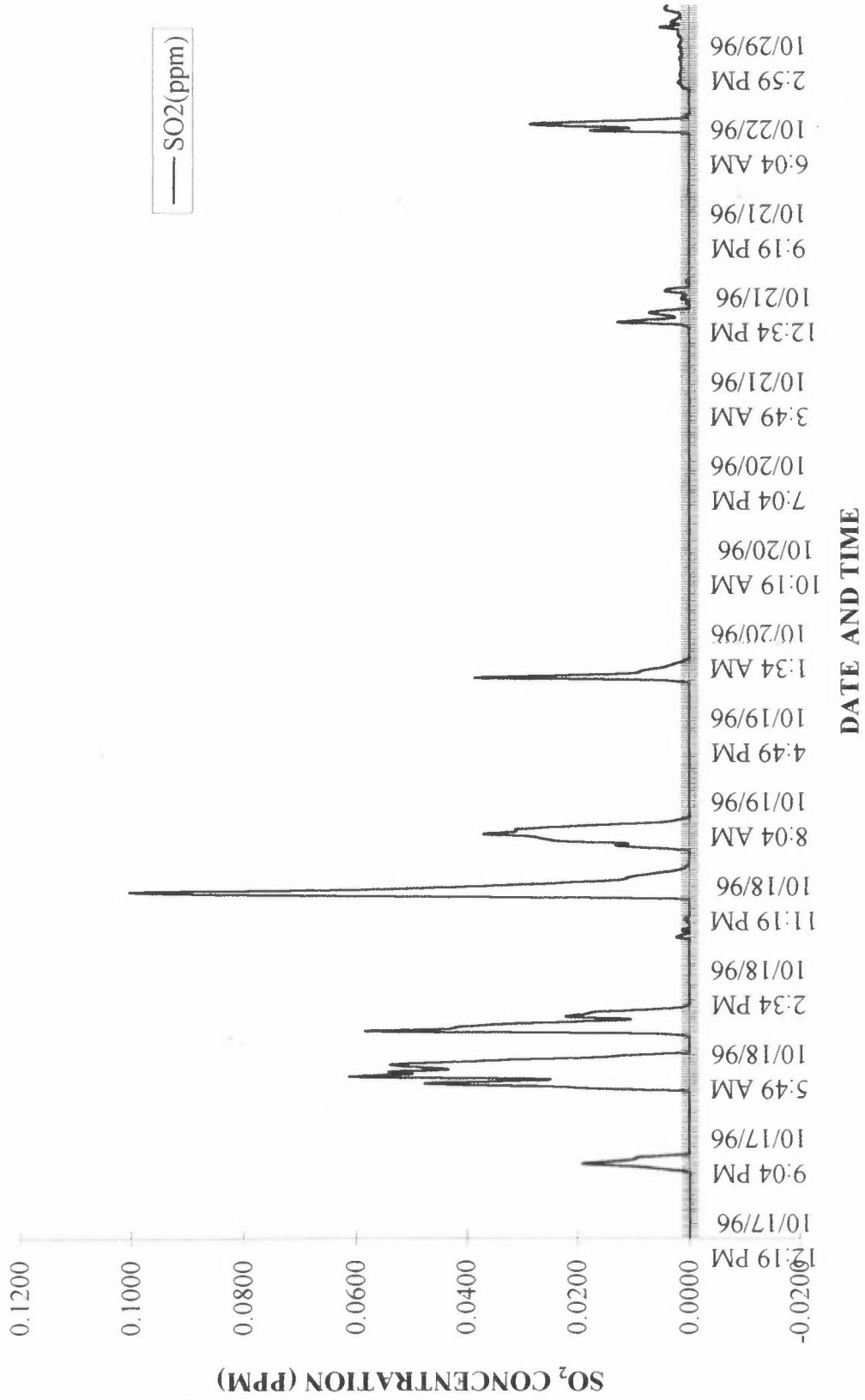

Appendix R
Selected air quality data Tonota

Selected air quality data from Tonota

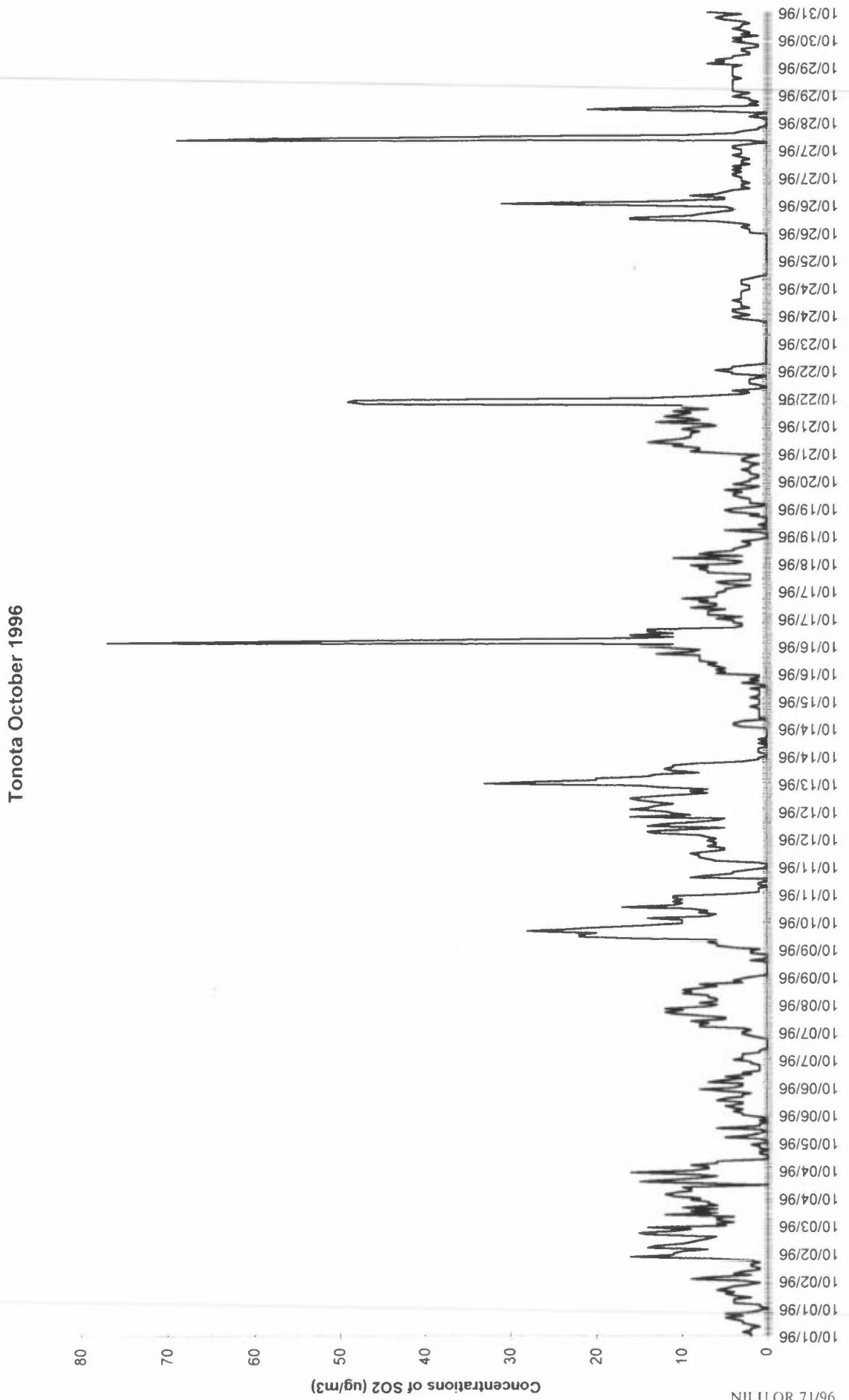

Tonota October 1996

Tonota october 1996

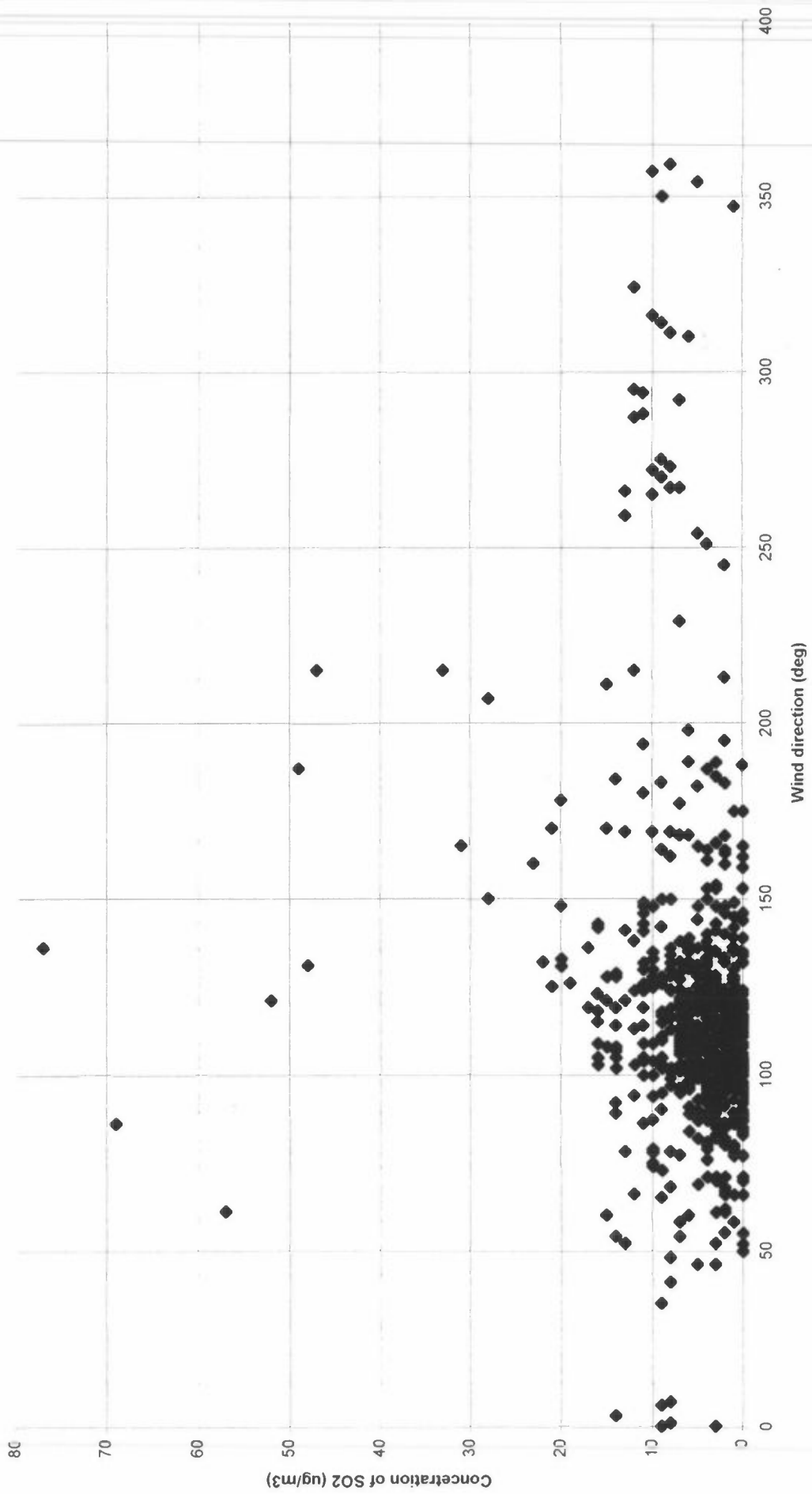

Appendix S

Selected air quality and meteorological data from Mmadinare

Selected air quality and meteorological data from Mmadinare

SO2 concentrations at Mmadinare in August 1996

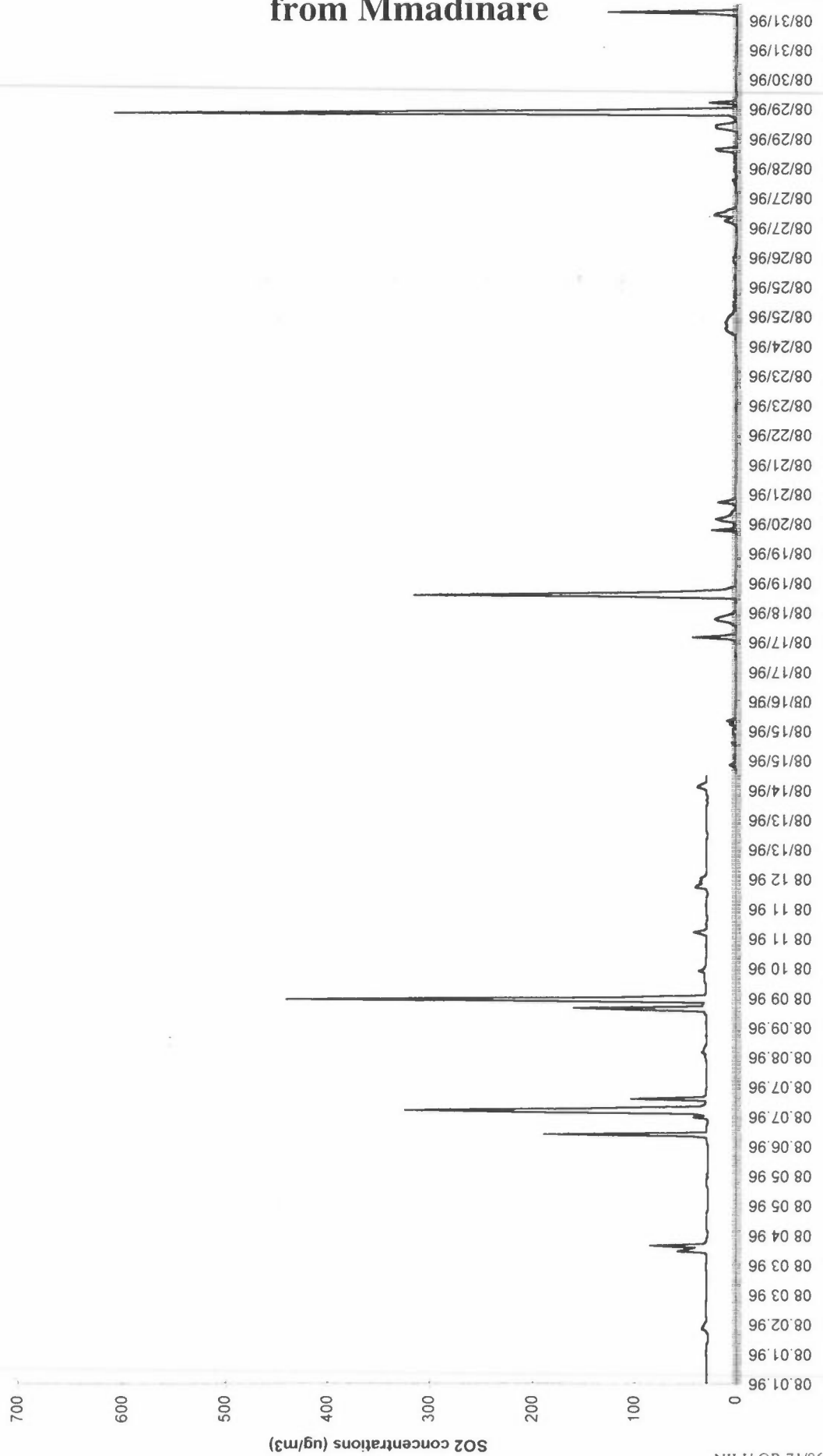

SO2 with wind direction at Mmadinare in August 1996

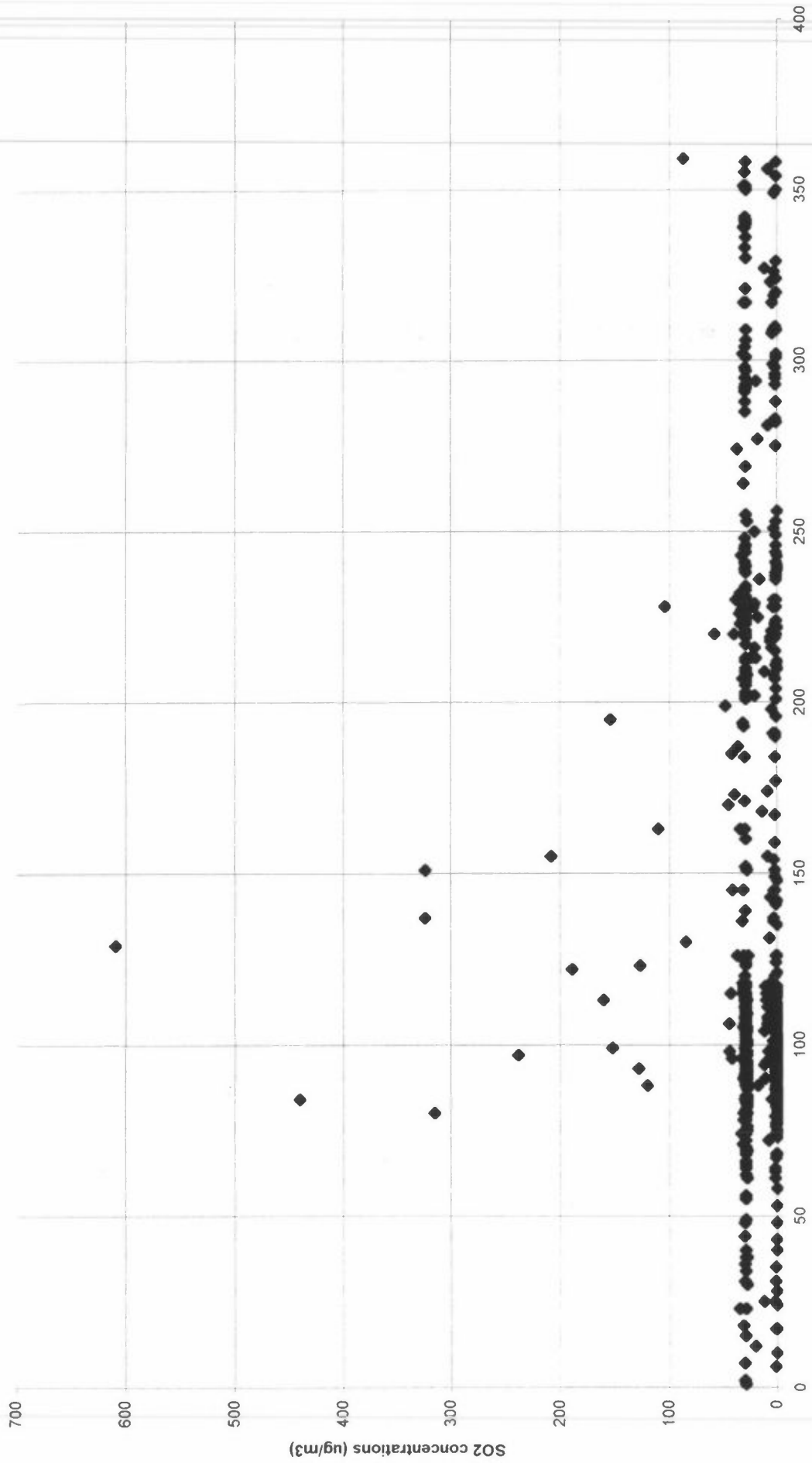

SO2 concentrations at Mmadinare in July 1996

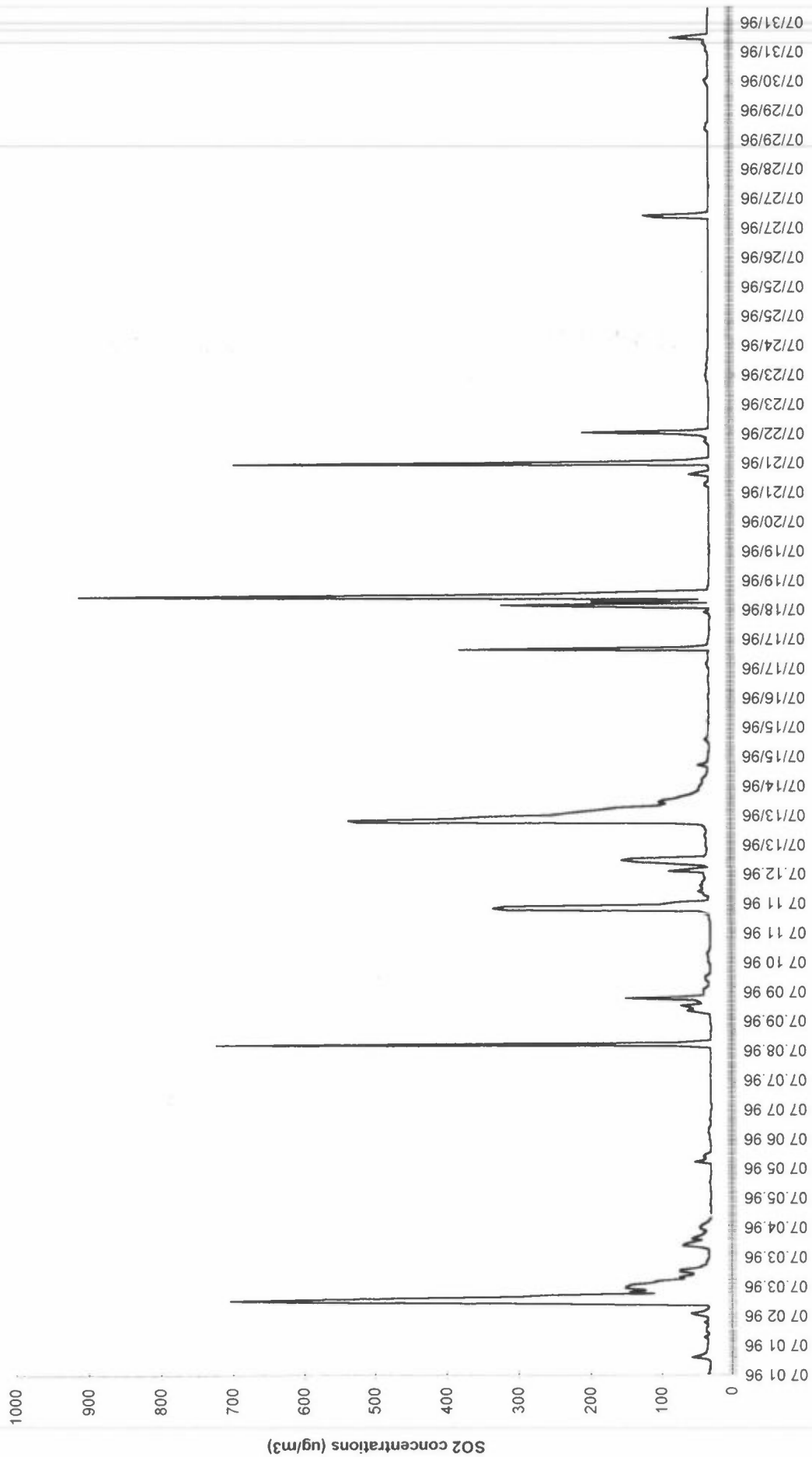

SO2 concentrations at Mmadinare in september 1996

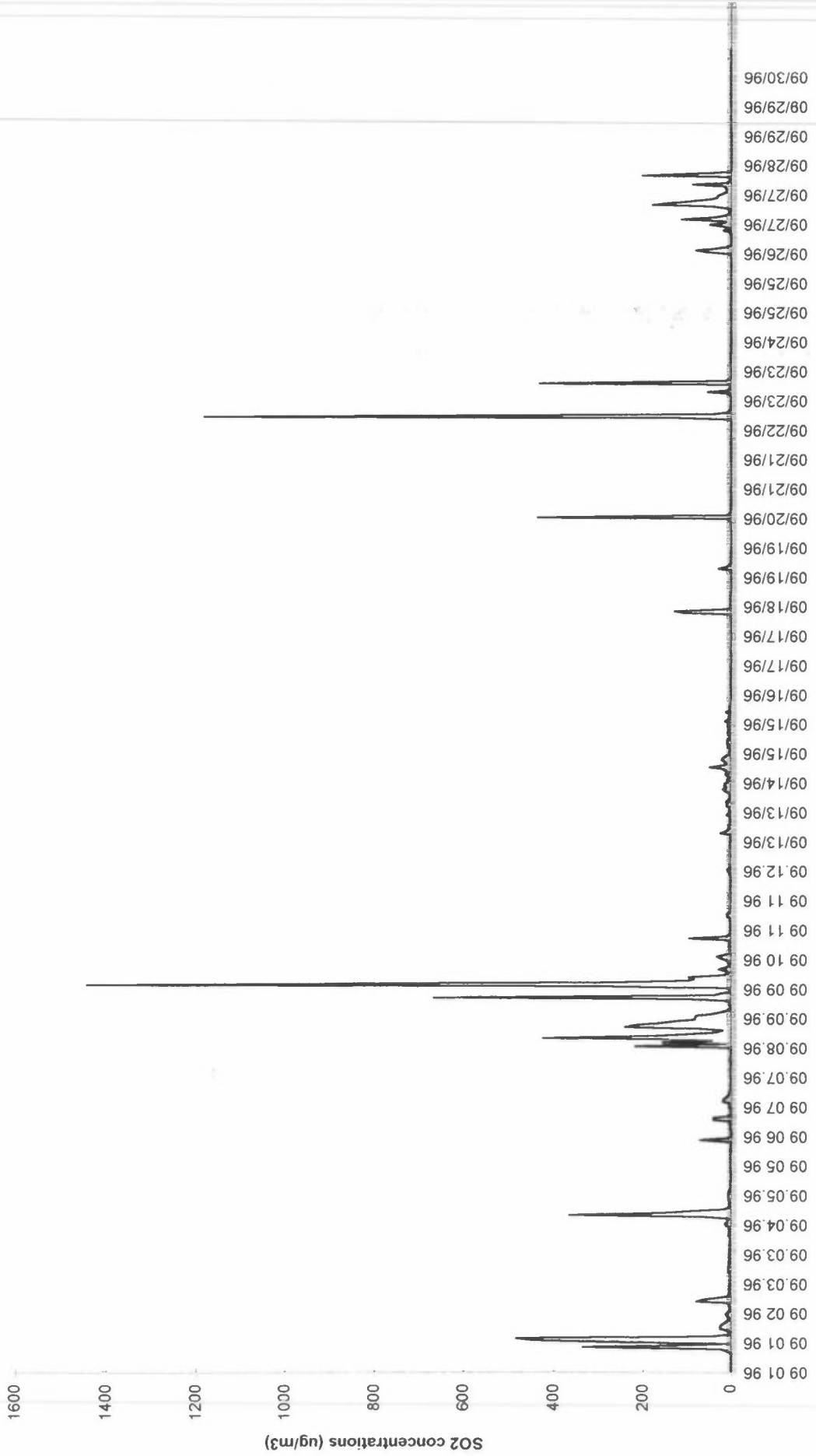

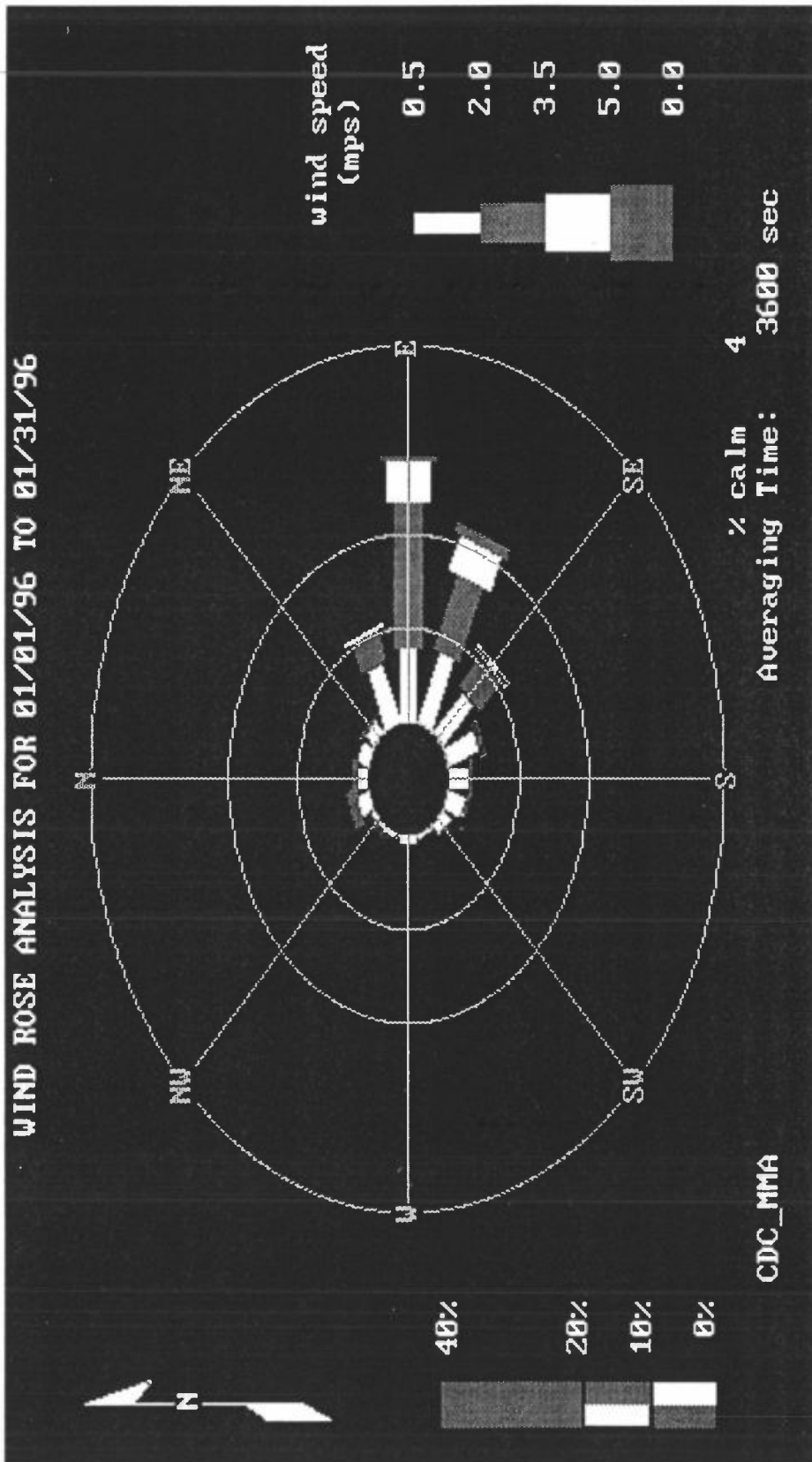

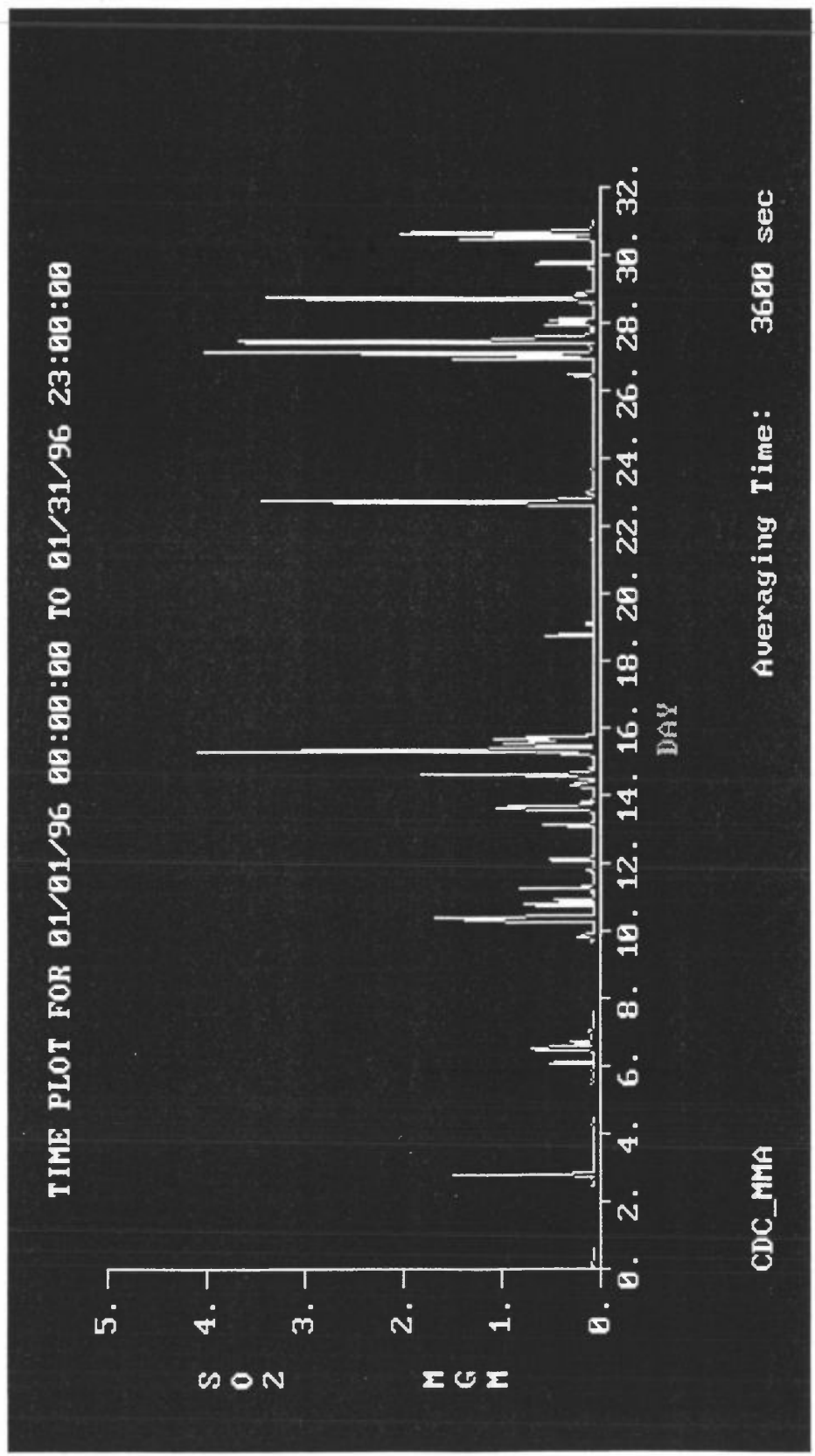

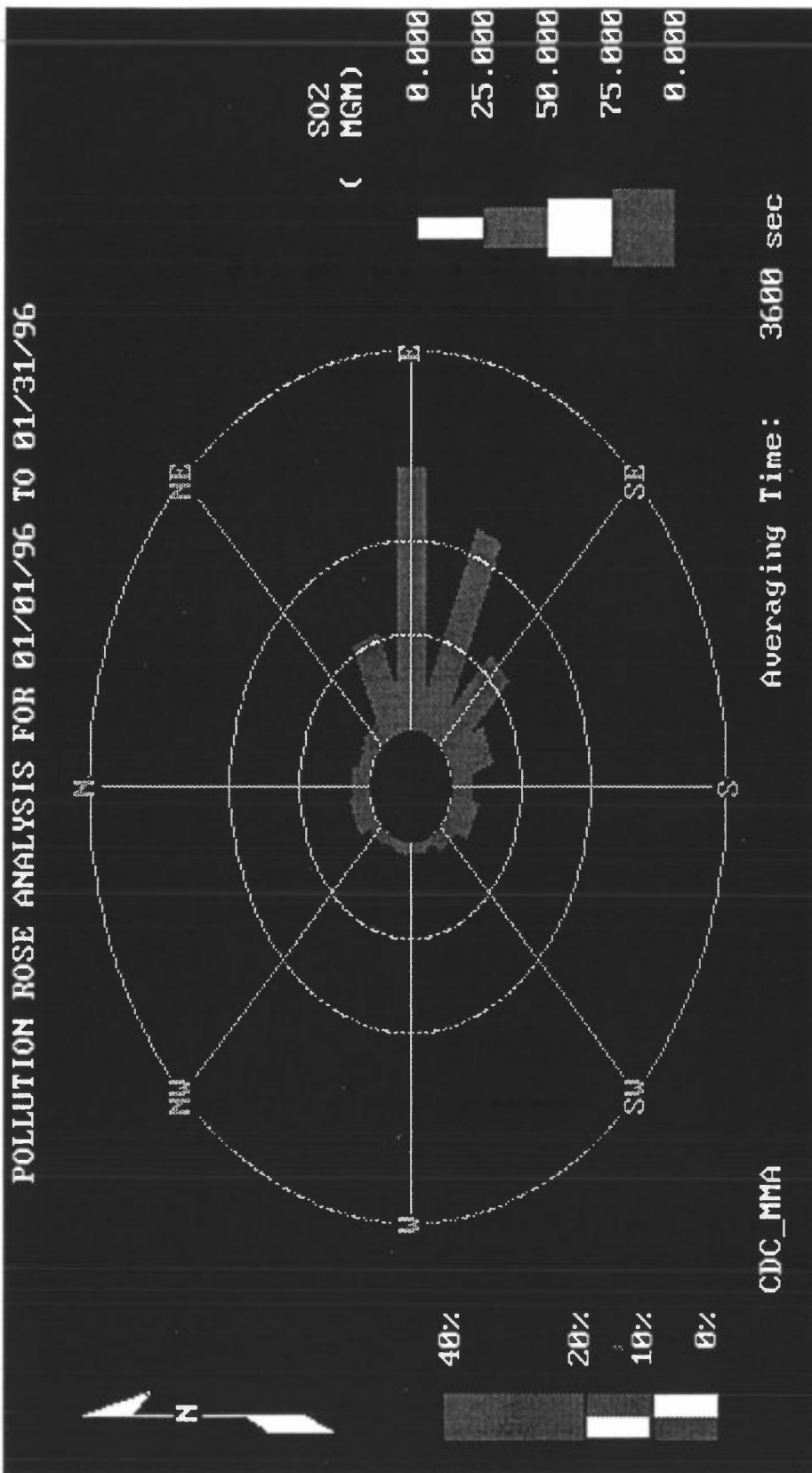

Appendix T

Example of forms from emission inventory

Example of forms from emission inventory

EMISSION INVENTORY

FORM A

Business or company names: Kgalagadi Soap Industries
 Plot Number: _____ Town/Village: Gaborone
 Postal Address: P.O. Box 1900 Gaborone
 Contact Person: _____
 Phone Number: 312791 Fax number: 312793

GENERAL PLANT DATA

Type of business/trade: Soap Making
 Geographical location and height of discharge point

x coordinate					y coordinate					Stack ht.			
km		m			km		m			m			
												2	3

Internal stack diameter (at the top) _____ 600 mm

Number of sources discharging through the stack _____ 1

NB Please complete a separate form for each source

Volume of the gas: _____ Nm³/h* or Velocity: _____ m/s

Flue gas temperature: 215 °C

Fuel characteristics

Type: coal Origin: Mosimpele

Amount consumed: 20 tonnes/week

Analysis: C 72.99 % H 3.96 % O 4.94 %

N 1.81 % S 1.00 % Ash 12 ^{13.5} %

CV 25.3 ^{25.2} % MJ/kg or MJ/m³

Other(specify) _____

Fuel usage (heating, power/steam-production etc.) _____

Producing Steam

Regular shutdowns: _____

Diurnal variation of fuel consumption (ie. weekly, monthly or yearly) _____

Emission control appliances (specify type and efficiency): _____

*Volume of the gas per hour at 0°C an 101.3 kPa (760 mm Hg)

Appendix U

Dust sampling at the Lobatse clay works

DUST SAMPLING AT THE LOBATSE CLAY

WORKS

1996

Prepared by: **Moore Moffat**
 Jacob Modise
 Lucas Ntsipe

1. Summary

The Department of Mines is currently conducting dust sampling in some industrial plants around the country, to assess personnel occupational exposure in those respective plants. This study considered Lobatse Clay Works dust Situation.

Dust sampling was done at the following plant's locations:

- The Clay Preparation
- The Extruder
- Unloading Zone
- Personnel Office
- Operations Manager's Office

Some samples were subjected to a semi-quantitative and qualitative analysis, while others were subjected to a gravimetric analysis only. The semi-quantitative analysis showed that the samples were composed of quartz as a major component, feldspar and mica as minor components. Correlation of the semi-quantitative and the qualitative results with the gravimetric results indicated that quartz is in excess of the 0.1 mg/m^3 respirable dust Threshold Limit Value, recommended by American Conference of Governmental Industrial Hygienist. The Threshold Limit Value was exceeded in all the sampling areas except sample no.2 (the personnel offices) (see tables 1-5).

Quartz levels in excess of the threshold Limit Value is believed to have detrimental effects on its subjects.

Two dust extraction equipment were not operational, however operation of this equipment could alleviate the dust problem in the plant. Respirator used to protect employees from dust exposure were observed to be inefficient, therefore more reliable respirators should be used.

It was realized that Lobatse Clay Works (L.C.W) has not been registered in accordance with the Atmospheric Pollution Prevention Act, however registration forms were issued to the management of L.C.W for completion and submission to the Air Pollution Control Officer. Conditions in the registration certificate should require L.C.W to setup a dust monitoring program in the plant result of which should be reported to the Air Pollution Control Officer.

2. Introduction

This report entails a week long observations and monitoring of dust at Lobatse Clay Works. The objectives of the study was to asses dust problems and possible solutions for L.C.W . The main sampling areas were within the plant at :

- The Clay Preparation
- The Extruder
- Unloading Zone
- Personnel Office
- Operations Manager's Office

Respirable dust samplers were used to collect the samples . An X-ray Diffraction Machine from the Department of Geological Survey was used to make a semi-quantitative and qualitative analysis of some of the samples . A gravimetric method was used to analyze other samples .

L.C.W. plant process the Woodhall Clay Deposits to make bricks , additional clay comes from South Africa . The South African and the Woodhall clays are mixed on a 2:3 ratio basis , depending on the required product (brick) , respectively . The South African clay was not used during the sampling period . The plant processes X tones of clay to produce 4 million bricks per month . The Woodhall Clay is composed of about 94% quartz , 2% feldspar , 2% mica and 2% of opaque minerals . However , information on the mineral composition of the South African clay is not available . The plant operates a three 8 hours shift per day

The presence of excessive quartz in respirable dust is known to have some adverse effects on its subjects .

3. Equipment and Sampling Procedures

Three respirable dust samplers were used to collect the samples . The sampler were calibrated using a Digital Optiflow Calibration Kit .

Prewighed filters were put into filter cassettes and connected to a cyclone and a pump . The setup is then attached to an operator during the rest of the sampling period , normally 8 hours . At the end of the sampling period the filter is reweighed to determine the amount of dust in a given amount of air .

An X-ray Diffraction Machine was used to do a semi-quantitative and qualitative analysis of some of the samples .

4. Results

The following equation were used to determine the dust concentrations:

$$V = Q * T / 1000$$

- where V, is the sample volume
- Q, is the flowrate of the pump
- and T is the elapsed sampling time

$$C = W / V$$

- where C, is the dust concentration
- and W is the weight of the sampled dust

(A) Gravimetric Analysis

Table 1

DAY 1 RESULTS			
SAMPLE NO.	1	2	3
SAMPLE LOCATION	EXTRUDER	PERSONNEL OFFICE	UNLOADING ZONE
DUST CONCENTRATION (mg/m ³)	0.2688	0.000	0.5606

Table 2

DAY 2 RESULTS			
SAMPLE NO.	4	5	6
SAMPLE LOCATION	CLAY PREPARATION	EXTRUDER	CLAY PREPARATION
DUST CONCENTRATION (mg/m ³)	4.3117	0.4545	9.0909

Table 3

DAY 3 RESULTS			
SAMPLE NO.	7	8	9
SAMPLE LOCATION	CLAY PREPARATION	CLAY PREPARATION	EXTRUDER
DUST CONCENTRATION (mg/m ³)	138.55	2148.52	15.87

Table 4

DAY 4 RESULTS			
SAMPLE NO.	10	11	12
SAMPLE LOCATION	CLAY PREPARATION	CLAY PREPARATION	CLAY PREPARATION
DUST CONCENTRATION (mg/m ³)	11,368.6	4733.1	691.3

Table 5

DAY 5 RESULTS			
SAMPLE NO.	13	14	15
SAMPLE LOCATION	O.M. OFFICE	M.M. OFFICE	PERSONNEL OFFICE
DUST CONCENTRATION (mg/m ³)	0.139	0.1533	0.1521

(B) X-Ray Diffraction

Table 6: X-Ray Diffraction(XRD) results of dust samples from Lobatse Clay Works

Sender No	Laboratory No.	Main Component	Secondary Component	Traces
M228-J21- 4	M/6296	Quartz		Feldspar
M228-J21-6	M/6297	”		”
M228-j21-10	M/6298	”	Chlorite,Mica.	”
M228-j21-11	M/6299	”	” ”	”
M228-j21-12	M/6300	”	” ”	”

Table 7: Threshold Limit Values(TLV) for Chemical Substances(1990-1991)

Substance	TWA(mg/m ³)
Quartz	0.1
Mica	3
Chlorite	-----
Feldspar	-----

Table 8: Quantitative mineral determination of 3 brick-earth samples from woodhall brick -earth deposit(From G.S report)

Component	Average
Quartz	94%
Feldspar	2%
Opaque minerals	2%
Mica	2%

5. Discussion of Results

A semi-quantitative analysis of the dust samples indicated that quartz is a major component of the samples with feldspar ,mica and opaque minerals occupying the rest . Since the dust samples were collected from L.C.W. which processes the Woodhall Clay , it is expected that the quantitative analysis of the dust should have marked resemblance of the premining Woodhall Clay Deposit (table 8) .

Correlation of the gravimetric results , semi-quantitative results and the fact quartz constitute a major part of the samples , it is evident that quartz levels are in excess of the 0.1 mg/m³ Threshold Limit Value in all the sampling locations except sample no.2 in the personnel the office .

However , the mineral composition of the South African clay is not known , therefore this may lead to misinterpretation of the general state of dust in the plant . A full quantitative analysis of the samples can resolve this problem .

6. Conclusions and Recommendations

Given the dust concentration in the respective sampling areas and Threshold Limit Values for quartz , L.C.W. may have a serious dust problem , which may result in dust related occupational diseases .

A full quantitative analysis of the samples will be required so that proper interpretation of the results can be achieved . The mineral component of the South African clay should be established for background information .

The respirators used by the operators in the plant were perceived to be inefficient , therefore reliable respirator should be used . Dust extraction equipment should be put back into operation to alleviate the dust problem .

Upon considering the L.C.W source registration application , the terms and conditions on the registration certificate should require L.C.W. to monitor dust and produce monthly report .

Appendix V

Emission data from the BCL smelter in Selebi-Phikwe

BCL Limited Energy Usage

- **Gomolemo Laurence Mosweunyane**
- **Environmental Engineer**
- **28th to 29th October 1996**
- **Boipuso Hall. Gaborone. Botswana**



Guiding Principles

- ✓ Company Environmental Policy states that; "BCL Management will aim to achieve the principles of sustainable consumption by conserving the use of water, energy and materials".
- ✓ Cost Saving; any saving and/or recovery of energy would reduce the costs and is an incentive for management to encourage sustainable energy usage.

Electricity Consumption (MWh)	1991	1992	1993	1994	1995	1996
Jan	29542	29983	30370	30679	30286	32008
Feb	26578	27938	26432	28144	31694	30673
Mar	29259	30885	30165	30900	31844	33513
Apr	28481	25446	28938	29787	30304	30724
May	29481	30550	30253	30666	26610	33174
Jun	28199	29779	29346	29647	17353	32811
Jul	29022	29985	30166	30079	26252	33125
Aug	29876	31635	30339	30782	32492	33514
Sep	28246	29994	29610	28327	31694	
Oct	28813	31566	31245	30465	32500	
Nov	29064	30539	28973	29420	33479	
Dec	29532	30504	29964	30941	33479	
Total	346093	358804	355801	359837	357987	259542

BCL Limited Electricity Consumption

Monthly Totals 1991 to date

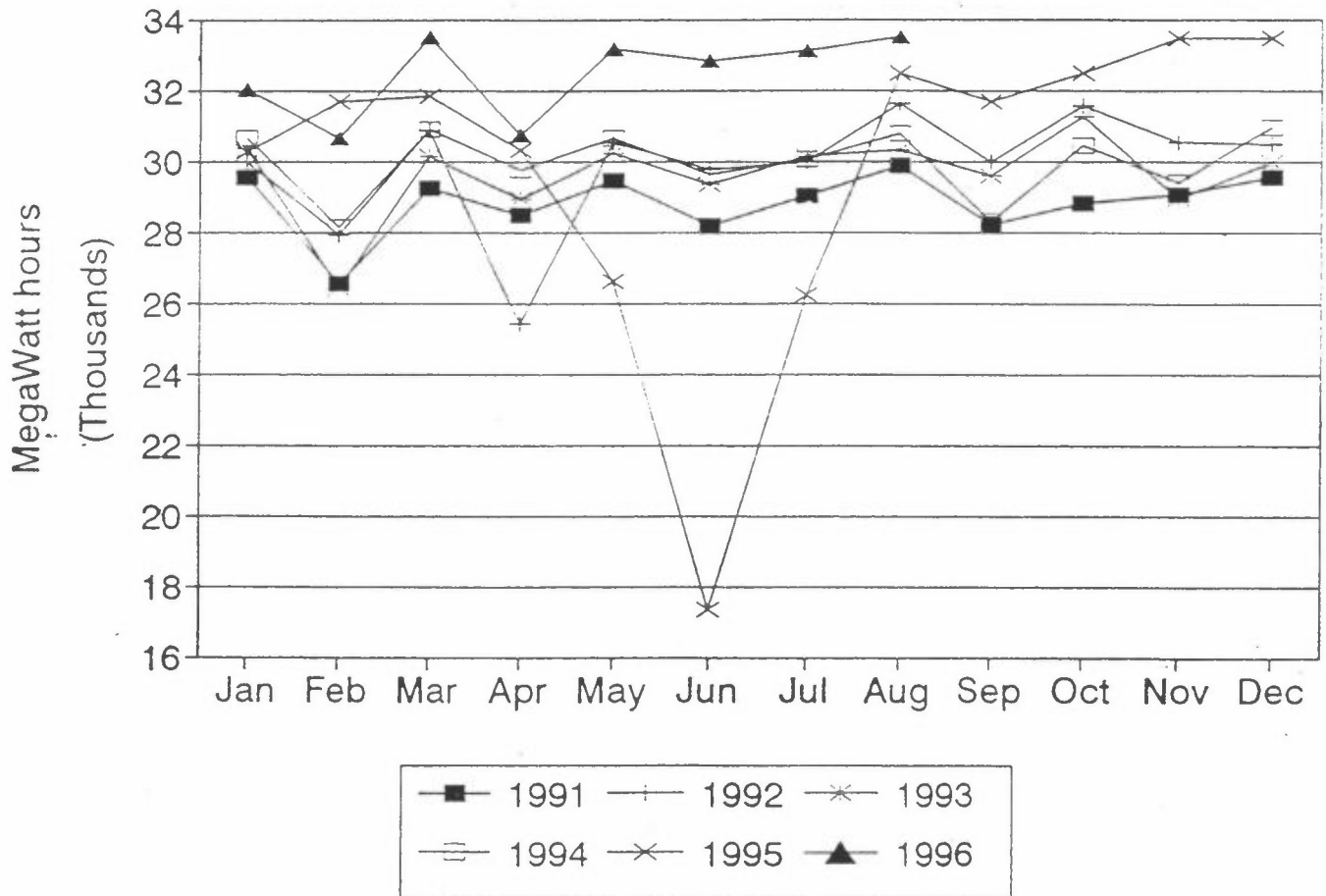

BCL Limited Monthly Coal Consumption for 1996

	C.Plant	D.Plant	F.Furnace	Converters	Loco's	Electric Furnace	Total	P59.53/t
Jan	92	4462	7458	468	365	638	13483	802642.99
Feb	83	4047	6798	434	217	416	11995	714062
Mar	93	4544	7646	485	232	487	13487	802881
Apr	77	3752	6428	476	232	325	11290	672094
May	93	4392	7812	516	256	444	13513	804429
Jun	90	4600	7279	465	366	403	13203	785975
Jul	45	2188	3758	475	369	202	7037	418913
Aug	93	4520	7755	453	246	426	13493	803238
Sep	90	4273	7617	446	251	397	13074	778295
							110575	6582530

Annual Averages (1991 - 1995)

	C.Plant	D.Plant	F.Furnace	Converters	c/v	E.Furnace	Total	Pula
1991	1006	52235	85860	5769	6775	5126	156771	8929262
1992	1070	53408	85355	6211	7281	5719	159044	9034451
1993	1071	55087	85707	6493	7564	4809	160731	9118032
1994	1029	50498	85173	6064	7093	4737	154594	8780735
1995	925	44273	73661	4717	5642	5911	135129	7708361

Annual/Monthly Consumption of Petrol and Diesel

Petrol

	1991	- 1992	1993	1994	1995	1996
Jan	18814	20212	17411	17535	18275	23044
Feb	18425	21016	18291	17619	19728	20885
Mar	17050	22632	19531	19483	22857	21089
Apr	19055	21636	18276	17320	22373	20852
May	19673	18987	18274	18814	28588	21380
Jun	18976	21159	18909	19501	33456	20654
Jul	19669	20905	18917	18406	25976	15800
Aug	21289	19213	19033	19106	20304	21941
Sep	17700	19562	17841	19658	17992	21762
Oct	19698	20497	18253	18597	20958	
Nov	22730	19007	18998	19635	20785	
Dec	20407	18297	18532	19030	22273	
	233486	243123	222266	224704	273565	187407

Diesel

	1991	1992	1993	1994	1995	1996
Jan	111666	99554	85941	103976	135010	124981
Feb	107534	98791	76435	119686	131803	114965
Mar	105015	95863	89064	117833	154482	112952
Apr	114979	82464	82787	126246	98512	124267
May	117203	101520	85139	126372	120367	143989
Jun	112092	103250	89002	123400	158464	141951
Jul	109530	101024	90045	132572	126690	125757
Aug	118456	97738	84125	147699	128165	155784
Sep	96917	96332	102480	138950	105432	150982
Oct	89050	94251	106738	117937	113574	
Nov	128255	92329	114252	131717	108023	
Dec	111412	91013	107252	139910	121258	
	1322109	1154129	1113260	1526298	1501780	1195628

BCL Limited Annual Consumption Petrol, Diesel(Litres) and Coal(Tonnes)

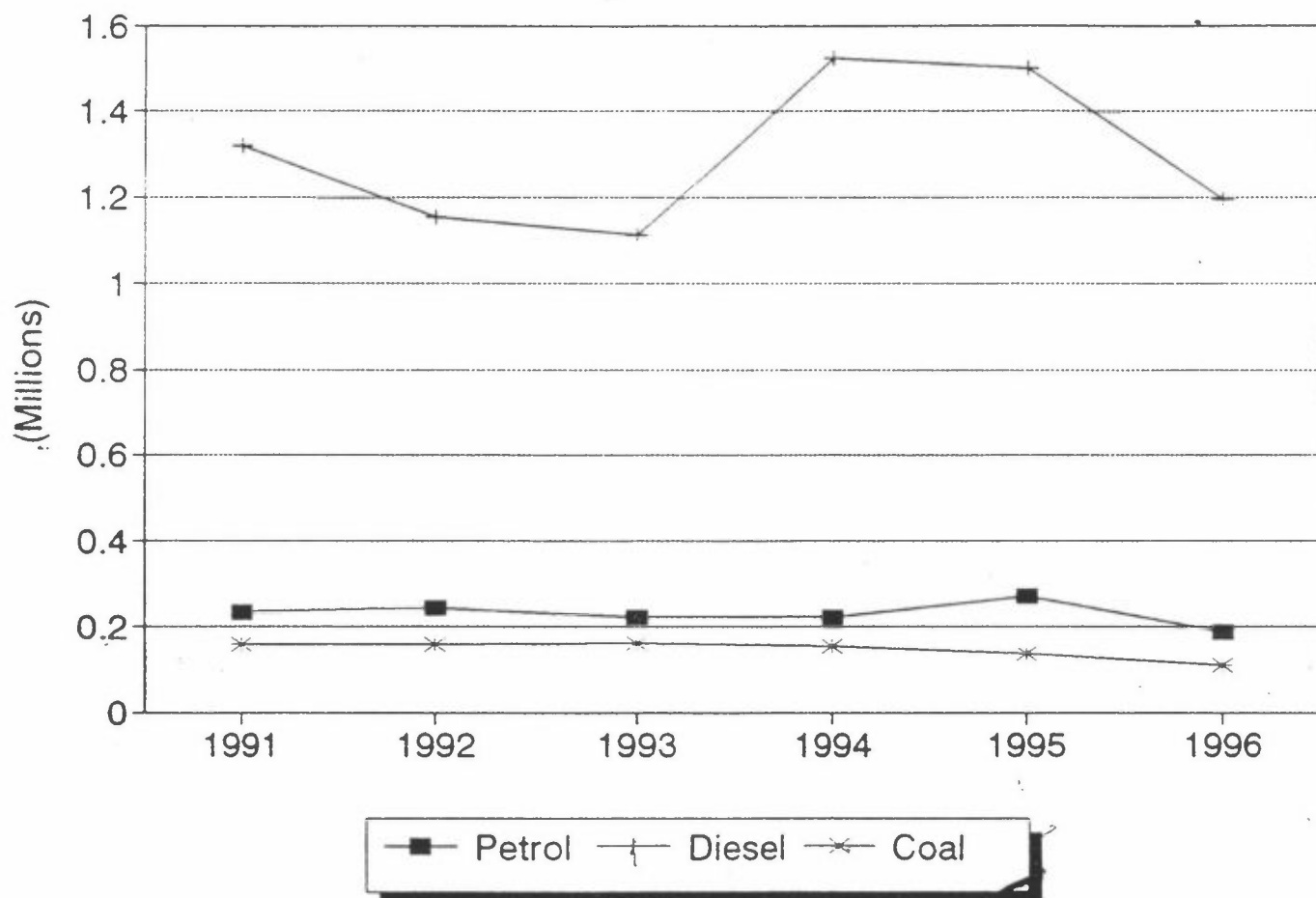



Energy Consumption and Costs

- ✓ Electricity: 350 000 MWh @ P4.5 m per month = P54m per annum.
- ✓ Coal: 150 000 tonnes @ P59.53 = P9 m
- ✓ Heavy Furnace Oil 150 000 Litres @ P0.99 = P1.782m
- ✓ Diesel: 120 000 Litres @ P1.074 = P128 880
- ✓ Petrol: 23 000 Litres @ P1.096 = P 25 000
- ✓ Total estimate = P65m per annum.



Energy Saving Measures

- ✓ An investigation is ongoing to supplement the Heavy Furnace Oil with Industrial Burning Oil. IBO is blended from waste oil. A proposal is awaited from Shell/Industrial Furnace Fuels to collect all waste oil from BCL and to supply IBO and a reduced cost.
- ✓ Education of the general workforce
- ✓ It is expected that in 1997 a new Oxygen Plant will be commissioned. It is expected that Coal consumption will reduce by about 40 000 tonnes. But electricity consumption will increase by about 26 700MWh.
- ✓ $26700 \text{ MWh} * 0.57\text{tonnes} = 15219\text{tonnes}$
 $40\ 000 - 15219 = 24781$ Coal tonnes may be saved.

Energy Recovery

- ✓ Process heat from the Boilers is used in Reactionary heaters and to generate ice to the underground working environment. The ice plant uses about 37% as steam of the total 100 tonnes per hour of water from boilers.

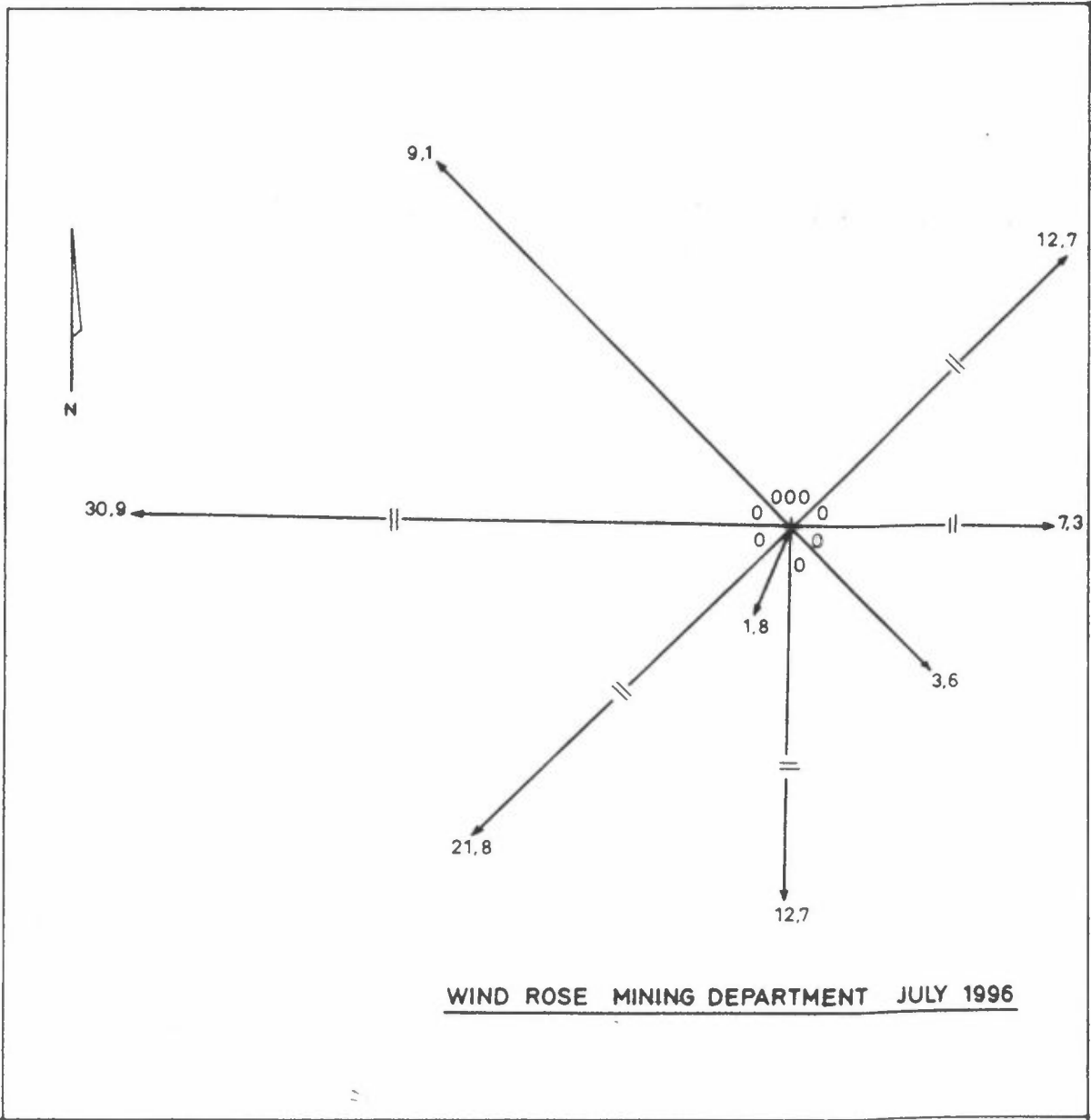

Appendix W

**Pictures of the BCL smelter
in Selebi-Phikwe**

Pictures of the BCL smelter in Selebi-Phikwe



9/11-96
6 PM

10/11-96 →



9/11-96 ↕



Appendix X

**Environmental Control Report September 1996
BCL Limited**

ENVIRONMENTAL
CONTROL REPORT
SEPTEMBER 1996

EXECUTIVE SUMMARY

Pursuant to the Registration Certificate 81-4 [Atmospheric Pollution (Prevention) Act] the monthly Environmental Control Report for September 1996 is hereby issued.

Air Pollution

Winds prevailed (34% of time) from the east at average 3.6m/s thereby fanning the stack emissions away from the residential areas.

Sulphur Dioxide concentrations in the residential areas of Selebi-Phikwe were well below the limits for both the daily and monthly averages of 300 and 160 $\mu\text{g}/\text{m}^3$ of air respectively. Average particulate in air were less than 1 $\mu\text{g}/\text{m}^3$.

Water Pollution

The quality of effluent discharged to the Mathathane/Letlhakane/Motloutse river system generally complied with the Department of Water Affairs Guidelines, except for Sulphates which continued to slightly exceeded the 0.60 g/l limit. This is due to the increased fissure water pumped from No.3 Shaft. Investigations are underway to find the best practicable option to reduce or eliminate this problem.

Raw and potable water consumption have remained fairly constant since 1990 when strict water conservation measures were introduced, this goes for effluent.

Results of the dry season Soil and Vegetation analysis have now been received and a report will soon be made.

There is nothing out of the ordinary to report on regarding other routine environmental activities such as ; the Control of Substances Hazardous to Health and, Industrial and Occupational Hygiene monitoring.



Gomolemo. L. Mosweunyane
ENVIRONMENTAL ENGINEER

SEPTEMBER 1996

DISTANCES FROM MAIN STACK OF BCL LIMITED AGL MONITORS

<u>MONITORING STATION</u>	<u>DISTANCE in Km</u>
1 SMELTER WEST	0.2
2 SMELTER EAST (NOT IN USE)	0.4
3 SLAG TAPPING FLOOR	0.08
4 WUC	1.1
5 RAILWAY STATION	4.0
6 GOVERNMENT HOSPITAL	4.0
7 LOW DENSITY AREA	4.7
8 BCL FAMILIES CLINIC	3.4
9 BOTSHABELO	3.8
10 BPC	0.2

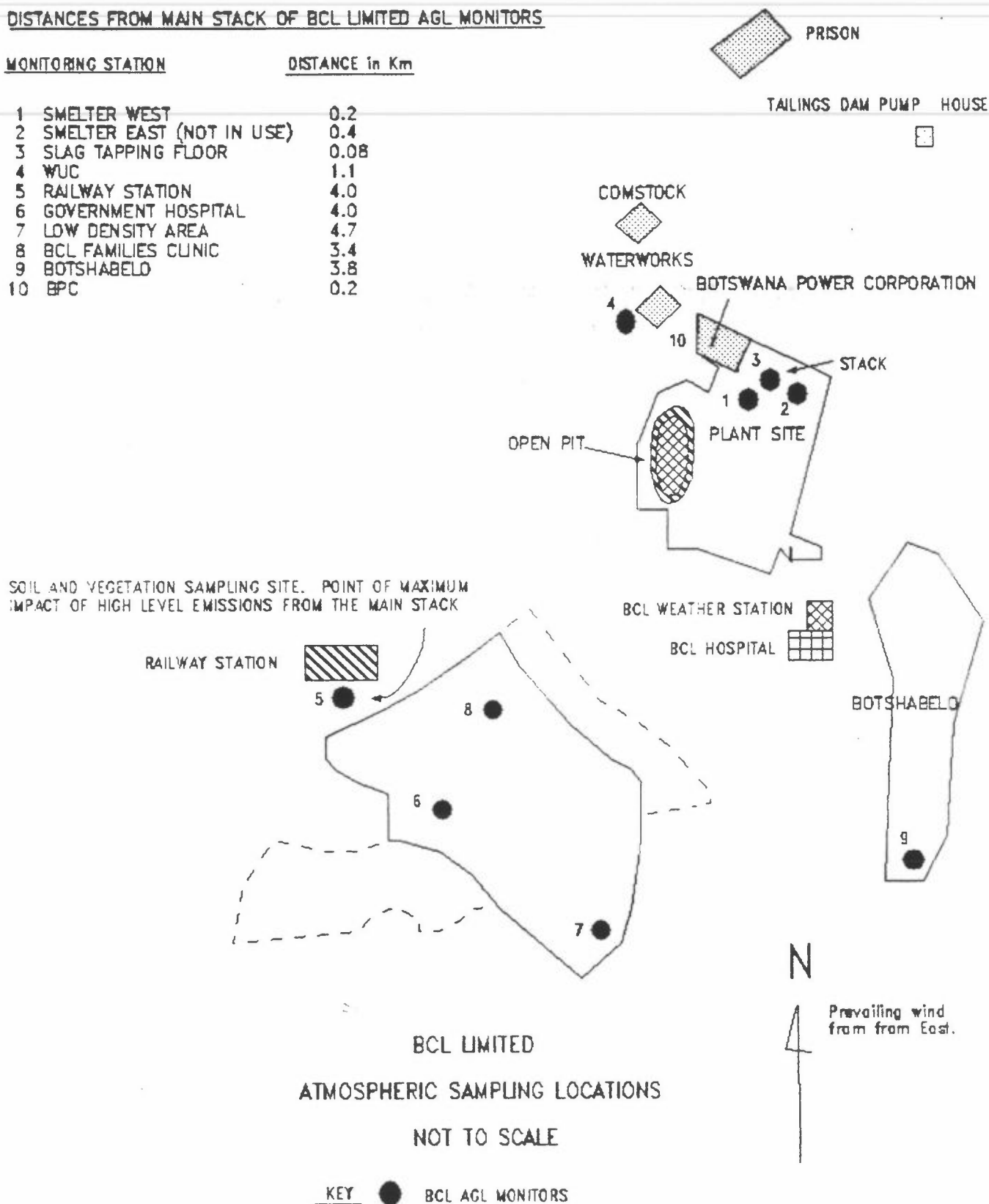

FIGURE 1

1.0 SULPHUR DIOXIDE SAMPLING

Listed below in Table 1.1 are yearly comparisons of sulphur dioxide levels for September 1980 to September 1996.

Table 1.2 overleaf shows yearly mean sulphur dioxide levels from 1976 to 1995 and monthly means for January to September 1996.

Table 1.3 overleaf shows daily sulphur dioxide estimates at AGL sampling locations in the Selebi Phikwe area and the BCL plant site for the month of September 1996.

Year	S T F	Smelter West	Low Density Area	Govern. Hospital	BCL Family Clinic	Botshab.	W U C	Railway Station	B P C
1980	42610	5160	40	40		60	60	90	
1981	48230	950	70	30		40	250	100	
1982	24440	700	100	50		30	210	230	
1983	10710	1310	190	120		60	240	200	
1984	25680	580	50	70	100	40	210	150	
1985	5100	1390	80	200	250	50	310	180	
1986		760	90	70	40		60	130	
1987	20180	570	20	10	50		50	80	
1988	16980	440	20	30	40	40	70	80	
1989	104030	1340	20	20	80	30	60	90	
1990	111870	2740	30	40	50	20	120	80	
1991	31110	2100	20	40	60	20	100	100	180
1992	25670	1900	20	40	60	20	100	100	140
1993	41490	2450	20	60	70	60	140	90	140
1994	26840	1880	10	40	40	20	100	40	80
1995	13779	1439	10	31	36	12	77	50	75
1996	4276	944	1	36	55	7	44	60	78
Mean	34562	1568	47	55	72	34	129	109	116

Data was not available in respect of the following sampling sites:

STF	:	1986
BCL Families Clinic	:	1980 to 1983
Botshabelo	:	1986 and 1987
BPC	:	1980 to 1990

Year/ Month	Smelter		Residential				Industrial		
	Slag Tapping Floor	Smelter West	Low Dens. Area	Gov. Hosp.	BCL Family Clinic	Botsb.	W U C	Railway Station	BPC
1976	*	1500	*	*	*	*	*	400	*
77	*	1900	80	70	*	*	*	140	*
78	*	1100	100	60	*	*	200	140	*
79	7430	1280	100	80	*	*	240	150	*
80	33960	3240	60	80	*	*	180	100	*
81	75210	4390	100	60	*	*	160	110	*
82	68100	1000	120	90	*	*	260	220	*
83	13600	1250	140	140	*	*	200	250	*
84	16250	830	60	100	160	*	170	150	*
85	13700	1450	150	170	270	*	320	220	*
86	6880	730	80	120	100	*	110	120	*
87	17890	530	10	30	20	50	100	90	*
88	26080	610	30	30	40	20	80	70	170
89	59250	1250	10	50	20	80	80	70	290
90	89560	1940	30	40	50	20	110	80	
91	27680	1830	20	40	50	20	120	80	180
92	28590	1970	20	40	50	20	100	80	130
93	33930	2050	10	40	40	30	110	70	120
94	26684	1808	13	26	36	18	97	48	111
95	18417	1346	8	27	38	15	76	47	80
J	7169	757	4	21	18	5	73	29	132
F	5386	356	2	24	8	2	36	7	32
M	4505	298	2	26	11	5	51	40	55
A	3239	830	2	23	20	12	66	58	60
M	1662	967	2	39	51	12	29	51	60
J	*	975	3	29	39	15	55	118	155
J	10232	795	7	44	43	24	41	71	136
A	5182	1108	3	23	22	17	63	66	86
S	4276	944	1	36	55	7	44	60	78
Max/Sep	8028	1758	17	188	249	34	113	138	214
Min/Sep	1745	318	0	0	0	0	0	0	20

* = AGL's out of order or monitoring was not done.

Table 1.3										
Daily Sulphur Dioxide Levels Recorded at AGL Sampling Locations, September 1996 (ug SO-2/m-3 air).										
Date	Smelter			Residential				Industrial		
	Slag Tapping Floor	Smelter West AGL2a	Smelter West AGL2b	Low Dens. Area	Gov. Hosp.	BCL Family Clinic	Botsb.	W U C	Rail Stat.	BPC
1	6384	601	608	0	30	12	6	113	62	101
2	2352	1105	1039	17	15	16	0	19	107	21
3	7630	1278	1327	0	6	15	0	62	63	136
4	7630	1278	1327	0	6	15	0	62	63	136
5	3094	614	625	0	0	63	0	34	39	214
6	1843	751	786	0	0	31	4	68	47	48
7	2405	442	485	0	15	23	0	27	37	51
8	2405	442	485	0	15	23	0	27	37	51
9	7285	1283	1405	0	188	204	6	0	80	130
10	5117	1306	1373	0	172	112	24	0	129	53
11	5117	1306	1373	0	172	112	24	0	129	53
12	1825	1306	1288	0	10	13	6	0	9	59
13	1825	1306	1288	0	10	13	6	0	9	59
14	2742	1323	1273	0	0	17	0	0	7	67
15	2742	1323	1273	0	0	17	0	0	7	67
16	8028	1724	1667	0	50	30	34	0	129	102
17	2246	605	629	0	52	44	31	75	44	60
18	2246	605	629	0	52	44	31	75	44	60
19	5840	1089	1085	0	0	0	0	41	10	50
20	5430	800	771	0	59	29	0	31	67	99
21	4749	1747	1758	0	0	3	2	56	69	104
22	4749	1447	1758	0	0	3	2	56	69	104
23	7320	680	595	0	0	38		20	138	24
24	3029	376	318	0	3	8		53	55	67
25	3029	376	318	0	3	8		53	55	67
26	1863	713	751	0	46	0		85	0	136
27	1745	905	880	0	42	0		57	15	20
28	5873	470	463	0	46	249		104	93	67
29	5873	470	463	0	46	249	0	104	93	67
30	5873	470	463	0	46	249	0	104	93	67
31										
Mean	4276	938	950	1	36	55	7	44	60	78
Max	8028	1747	1758	17	188	249	34	113	138	214
Min	1745	376	318	0	0	0	0	0	0	20

Shaded cells indicate that AGL was out of order.

2.0 ATMOSPHERIC DUST SAMPLING

Yearly comparisons between AGL atmospheric nickel and copper concentrations for the month of September are given below in table 2.1.

Weekly AGL Nickel and Copper Estimates for September 1996 are given overleaf in Table 2.2.

Table 2.1
Comparative Estimates of Nickel and Copper at BCL AGL Sampling Locations,
September 1980 to September 1996 (ug/m³ air).

Year		80	81	82	83	84	85	86	87	88	89	90	91	92	93	94	95	96	Mean
Smelter West	Ni	10	8	10	16	20	13	7	6	4	3	5	6	3	5	25	5	3	9
	Cu	21	15	16	26	39	17	11	9	5	4	4	7	5	6	36	4	3	14
Slag Tapping Floor	Ni	40	54	75	69	332	42			11	54	44	16	22	56	15		4	68
	Cu	95	142	140	128	472	45			18	98	72	24	40	69	19		7	98
Low Density Area	Ni	1	2	3	3	1	4	1	1	1	1	1	1	1	1	1	1	1	1
	Cu	1	1	1	10	2	1	3	1	1	2	1	1	1	1	1	1	1	1
Government Hospital	Ni	1	1	1	1	1	1	1	1	1	1	1	1	1	1	1	1	1	1
	Cu	1	1	2	3	2	2	3	*38	1	5	1	1	1	1	1	1	1	2
Botshabelo	Ni	1	1	1	1	1	1			1	1	1	1	1	1	1	1	1	1
	Cu	2	6	1	1	3	2			1	2	1	1	1	1			1	2
BCL Clinic	Ni					1	1	1	1	1	1	1	1	1	1	1	1	1	1
	Cu					2	2	3	1	1	2	1	1	1	1	1	2	1	2
WUC	Ni	1	3	2	1	1	1	3	1	1	1	1	1	1	1	1	1	1	1
	Cu	3	5	4	2	3	2	6	1	1	3	1	1	1	1	1	1	1	2
Railway Station	Ni	1	1	1	1	1	1	2	1	1	1	1	1	1	1	1	1	1	1
	Cu	1	2	3	4	1	4	1	1	2	1	1	1	1	1	1	1	1	1
BPC	Ni												1	1	1	1	1	1	1
	Cu												1	1	1	1	1	1	1

The shaded cells indicate less than 1 microgramme e 1

Blank spaces means that there was no data available during the year indicated.

The 1987 Government Hospital sample of 38 microgrammes of copper appears to be a contaminated laboratory sample. The result has been rejected and a value of 3 microgrammes has been assigned.

Table 2.2 Weekly Nickel and Copper Estimates at AGL Sampling Locations, September 1996 (ug/m-3 air).						
Weekly Period Sampler		Wk1	Wk2	Wk3	Wk4	Mean
Smelter West 1	Ni	3	2	2	3	3
	Cu	3	2	3	4	3
Smelter West 2	Ni	3	2	2	3	3
	Cu	3	3	2	4	3
Slag Tapping Floor	Ni	4	7	2	4	4
	Cu	7	13	4	4	7
Low Density Area	Ni	1	1	1	1	1
	Cu	1	1	1	1	1
Government Hospital	Ni	1	1	1	1	1
	Cu	1	1	1	1	1
Botshabelo	Ni	1	1	1	1	1
	Cu	1	1	1	1	1
BCL Family Clinic	Ni	1	1	1	1	1
	Cu	1	1	1	1	1
Water Utilities Corporation	Ni	1	1	1	1	1
	Cu	1	1	1	1	1
Railway Station	Ni	1	1	1	1	1
	Cu	1	1	1	1	1
BPC	Ni	1	1	1	1	1
	Cu	1	1	1	1	1
NOTE:						
Shaded cells means "less than 1".						
Blank spaces indicate that the AGL's were out of order.						

3.0 WATER SAMPLING

Tables relating to water sampling are given overleaf.

The table below lists maximum allowable discharge limits, set by the Department of Water Affairs, with World Health Organisation limits also listed for comparison. Note that nickel has not been listed by the DWA and BCL has, as a guide, denoted 1 ppm for this metal.

Property (mg/l or as specified)	Maximum allowable discharge or as specified:		
	WHO	Perennial streams	Ephemeral streams
Temperature	-	35	35
pH	6.5 to 8.5	6.5 to 9.0	5.5 to 9.0
Dissolved oxygen	-	75	75
Biological oxygen demand	-	20	30
Chlorine oxygen demand	-	30	75
Free & saline ammonia (as N)	-	1	10
Nitrate (as N)	10	2	-
Total phosphorus (as P)	-	1.5	-
Colour (TCU)	15	30	50
Total coliform (n/100ml)	10	5000	20000
Faecal coliform (n/100ml)	0	100	500
Arsenic	0.05	0.1	0.5
Boron	-	0.5	1
Zinc	5	5	5
Copper	1	1	1
Phenols	0.001	0.005	0.01
Lead	0.05	0.05	0.05
Cyanide	0.1	0.1	0.1
Chromium	0.05	0.05	0.5
Cadmium	0.005	0.005	0.05
Mercury	0.001	0.001	0.02
Selenium	0.01	0.01	0.05
Iron	0.3	1	1
Manganese	0.1	0.1	0.5
NICKEL (LIMIT SET BY BCL)			1
Sodium	200	400	600
Sulphate	400	400	600
Chloride	600	600	1000
Fluoride	1.5	1.5	2.5
Total dissolved solids	1000	1000	2000
Oil & scum		0	0

Water Sampling Sites

- #3 Shaft Machine Water Dam
- # 1 Shaft Machine Water Dam
- Main Plant Effluent Drain
- Slag Cooling Pond V-Notch
- Tailings Dam
- Clear Water Dam
- Tailings Dam Seepage Sump

- 8 Mathathane River
- 9 Letlhakane River
- 10 Motloutse River 3Km upstream Letlhakane
- 11 Motloutse 1Km Downstream Letlhakane
- 12 Motloutse 5Km Downstream Letlhakane
- 13 Tobane Village
- 14 Selebi Mine Clear Water Sump
- 15 Selebi North

13 Situated at Tobane 20Km from Site 11 →

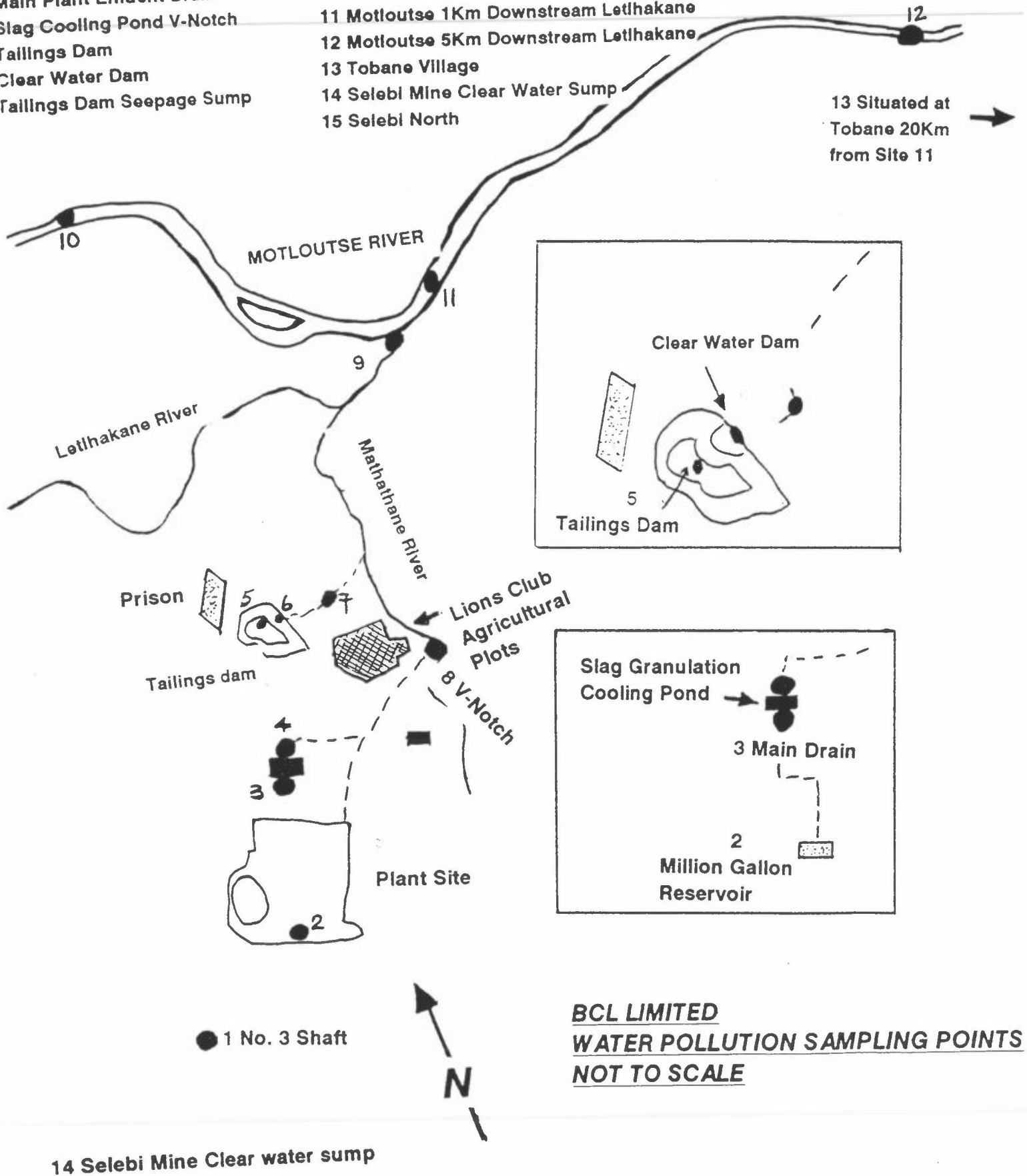

BCL LIMITED
WATER POLLUTION SAMPLING POINTS
NOT TO SCALE

14 Selebi Mine Clear water sump

Table 3-1a Weekly Effluent Analyses, September 1996.

No	Sample Source	Date	pH	ppm FSS	ppm TDS	ppm TH	ppm CaH	g/l SO-4	ppm MAIK	ppm Clrlds	ppm Oil	ppm Xanth.	ppm Cu	ppm Ni	ppm Fe	ppm Mn	ppm Co	ppm Pb	ppm Cd	ppm Hg	ppm Al
1	No 3 Shaft	03/09/96	7.9	108	3450	290	208	0.30	150	0	0	0.01	0.16	0.40	0.05	0.16	0.01	0.01	0.01	0.01	0.01
	Surface	10/09/96	8.0	16	1200	480	380	0.37	35	0	0	0.01	0.41	0.01	0.17	0.01	0.01	0.01	0.01	0.01	0.01
	Dam	17/09/96	7.8	36	210	80	40	0.01	130	0	0	0.01	0.01	0.26	0.01	0.19	0.01	0.01	0.01	0.01	0.01
2	No 1 Shaft	24/09/96	6.1	56	2970	1180	950	2.29	52	0	0	0.01	3.86	0.04	0.85	0.05	0.01	0.01	0.01	0.01	0.01
	Mine	03/09/96	7.3	8	3500	1590	1050	1.65	68	0	0.4	0.01	4.49	0.04	1.03	0.31	0.01	0.01	0.01	0.01	0.01
	Water	10/09/96	6.8	12	4060	1900	1180	1.91	12	0	0.5	0.01	6.19	0.18	1.88	0.34	0.01	0.01	0.01	0.01	0.01
3	Reservoir	17/09/96	5.2	20	3630	1750	1340	1.88	60	0	0.5	0.01	9.36	4.69	1.61	0.33	0.01	0.01	0.01	0.01	0.01
	Main	24/09/96	3.8	24	3950	1700	1230	1.82	8	0	0.5	0.01	8.00	20.85	1.94	0.09	0.01	0.01	0.01	0.01	0.01
	Plant	03/09/96	7.1	36	1090	508	290	0.49	110	0	0.02	0.02	2.42	0.44	0.31	0.18	0.01	0.01	0.01	0.01	0.01
4	Effluent	10/09/96	7.8	48	530	340	240	0.27	35	0	0	0.01	1.76	0.01	0.28	0.43	0.01	0.01	0.01	0.01	0.01
	Drain	17/09/96	6.1	41	1310	660	420	0.60	60	0	0	0.03	4.17	0.01	0.55	0.32	0.01	0.01	0.01	0.01	0.01
	V-Notch	24/09/96	6.4	44	1540	660	430	0.79	44	0	0	3.87	46.37	0.03	0.75	0.46	0.01	0.01	0.01	0.01	0.01
5	Failings	03/09/96	7.0	0	1250	580	370	0.64	52	0	0	0.01	3.90	0.48	0.34	0.21	0.01	0.01	0.01	0.01	0.01
	Dam	10/09/96	7.7	16	1230	600	480	0.58	17	0	0	0.01	3.38	0.01	0.32	0.37	0.01	0.01	0.01	0.01	0.01
	Failings	17/09/96	6.1	4	1040	500	270	0.62	52	0	0	0.02	2.64	0.01	0.24	0.25	0.01	0.01	0.01	0.01	0.01
6	Clear	24/09/96	6.0	12	760	610	430	0.75	28	0	0	0.01	4.90	0.07	0.51	0.01	0.01	0.01	0.01	0.01	0.01
	Water	03/09/96	5.2	80	4430	2190	1870	2.51	36	0	0	0.01	0.47	3.02	0.51	0.30	0.01	0.01	0.01	0.01	0.01
	Dam	10/09/96	5.7	88	4390	2520	1950	2.57	17	0	0	0.05	0.50	0.44	0.58	0.48	0.01	0.01	0.01	0.01	0.01
7	Clear	17/09/96	5.5	776	4900	2400	1940	2.64	80	0	0	0.03	2.77	28.50	2.66	0.26	0.01	0.01	0.01	0.01	0.01
	Water	24/09/96	5.6	100	4410	2120	1830	2.62	30	0	0	0.01	0.31	4.66	1.03	0.99	0.01	0.01	0.01	0.01	0.01
	Dam	03/09/96	2.5	36	8620	3020	1480	4.61	0	0	0.02	0.44	9.39	658.20	16.57	0.84	0.01	0.01	0.01	0.01	0.01
8	Failings	10/09/96	2.5	52	9390	3430	2400	4.21	0	0	0.02	0.35	9.24	398.80	12.22	0.40	0.01	0.01	0.01	0.01	0.01
	Water	17/09/96	2.5	16.1	8380	3090	1460	4.55	0	0	0.01	0.31	10.24	544.90	18.27	0.65	0.01	0.01	0.01	0.01	0.01
	Dam	24/09/96	2.1	52	7640	2860	1670	4.58	0	0	0.02	0.01	8.96	603.80	10.10	0.01	0.01	0.01	0.01	0.01	0.01
9	Failings	03/09/96	2.6	112	12190	3284	1390	5.12	0	0	0.02	0.21	10.49	955.00	19.67	0.98	0.01	0.01	0.01	0.01	0.01
	Water	10/09/96	2.7	136	13630	4000	3040	4.38	0	0	0.02	0.10	10.66	556.10	18.24	0.70	0.01	0.01	0.01	0.01	0.01
	Sump	17/09/96	2.7	120	12400	3260	1680	5.15	0	0	0.02	0.09	14.24	620.30	25.04	0.74	0.01	0.01	0.01	0.01	0.01
10	Sump	24/09/96	2.4	84	12700	3440	15	4.90	0	0	0.02	0.09	15.31	616.60	12.23	0.01	0.01	0.01	0.01	0.01	0.01
	0.01 means less than 0.01 ppm																				

Oil & xanthate are not analysed at sites 1, 3, 4 and 5. Chlorides are not analysed at sites 3 to 7.

Table 3 1b Weekly Effluent Analyses, September 1996

No	Sample Source	Date	pH	TSS	TDS	TH	CaH	SO-4	MAiK	Oil	Xanth	Cu	Ni	Fe	Mn	Co	Pb	Cd	Hg	AI
8	Mathathane	03.09.96	7.2	20	1600	780	410	1.01	42	1	0.2	0.01	3.24	0.3	0.56	0.19	0.01	0.01	0.01	0.01
	River	10.09.96	6.9	20	1660	790	550	0.91	13	1	0.2	0.01	2.70	0.24	0.55	0.24	0.01	0.01	0.01	0.01
		17.09.96	6.8	4	1430	670	350	0.84	68	1	0.2	0.02	2.16	0.45	0.49	0.08	0.01	0.01	0.01	0.01
		24.09.96	7.0	16	1550	650	450	0.86	44	1	0.2	0.01	2.87	0.21	0.60	0.01	0.01	0.01	0.01	0.01
9	Lethakane	03.09.96	8.0	8	1640	790	410	0.75	98	1	0.2	0.01	0.93	0.48	0.07	0.21	0.01	0.01	0.01	0.01
	River	10.09.96	7.9	24	1680	820	560	0.75	40	1	0.2	0.01	0.81	0.04	0.16	0.34	0.01	0.01	0.01	0.01
		17.09.96	8.4	40	1210	560	300	0.57	130	1	0.2	0.01	0.18	0.01	0.03	0.04	0.01	0.01	0.01	0.01
		24.09.96	7.7	36	1350	550	380	0.67	122	1	0.2	0.01	0.16	0.01	0.02	0.01	0.01	0.01	0.01	0.01
10	Motloutse	03.09.96	7.5	168	220	140	90	0.04	182	1	0.2	0.01	0.01	0.51	0.45	0.01	0.01	0.01	0.01	0.01
	River 3km	10.09.96	7.6	16	160	120	70	0.01	66	1	0.2	0.01	0.01	0.01	0.24	0.52	0.01	0.01	0.01	0.01
	Upstream	17.09.96	7.1	24	200	110	70	0.02	116	1	0.2	0.01	0.01	0.15	0.13	0.02	0.01	0.01	0.01	0.01
	Lethakane	24.09.96	7.6	24	240	100	80	0.05	134	1	0.2	0.02	0.01	0.018	0.01	0.01	0.01	0.01	0.01	0.01
11	Confluence	03.09.96	9.6	24	1680	780	490	0.73	70	1	0.2	0.01	0.03	0.49	0.08	0.15	0.01	0.01	0.01	0.01
	Motloutse/	10.09.96	9.7	20	1810	820	540	0.81	40	1	0.2	0.01	0.08	0.33	0.05	0.14	0.01	0.01	0.01	0.01
	Lethakane	17.09.96	8.9	20	1270	540	340	0.61	100	1	0.2	0.02	0.03	0.01	0.01	0.01	0.01	0.01	0.01	0.01
	Rivers	24.09.96	8.1	24	1310	550	390	0.65	122	1	0.0	0.01	0.26	0.01	0.01	0.01	0.01	0.01	0.01	0.01
12	Motloutse	03.09.96	9.5	128	1570	750	430	0.75	82	1	0.2	0.01	0.01	0.64	0.01	0.18	0.01	0.01	0.01	0.01
	5 km	10.09.96	9.1	12	1560	840	660	0.85	42	1	0.2	0.01	0.05	0.01	0.03	0.10	0.01	0.01	0.01	0.01
	Downstream	17.09.96	9.4	16	1290	570	360	0.63	98	1	0.2	0.01	0.01	0.01	0.01	0.01	0.01	0.01	0.01	0.01
	Lethakane	24.09.96	8.5	52	1550	670	450	0.81	96	1	0.0	0.01	0.12	0.01	0.01	0.01	0.01	0.01	0.01	0.01
13	Motloutse	03.09.96	7.4	20	210	130	90	0.13	110	1	0.2	0.01	0.01	0.46	0.01	0.12	0.01	0.01	0.01	0.01
	River	10.09.96	6.9	32	390	120	70	0.07	26	1	0.2	0.01	0.01	0.10	0.13	0.16	0.01	0.01	0.01	0.01
	at Tobane	17.09.96	7.8	4	190	110	80	0.03	112	1	0.2	0.02	0.01	0.01	0.16	0.02	0.01	0.01	0.01	0.01
	Village	24.09.96	7.8	88	250	110	80	0.08	88	1	0.2	0.01	0.01	0.01	0.25	0.41	0.01	0.01	0.01	0.01
14	Selebi	03.09.96	7.0	52	4630	1740	1230	1.44	52			0.01	26.72	1	0.79	2.61				
	Mine	10.09.96	6.6	64	4440	1770	1280	1.55	24			0.04	27.34	0.05	0.89	1.16				
	Clearwater	17.09.96	6.5	64	4660	1890	1440	1.54	80			0.02	48.93	0.08	0.81	0.92				
	Sump	24.09.96	6.4	68	4070	1750	1270	1.51	48			0.01	59.93	0.05	0.71	0.99				
15	Selebi	03.09.96	3.7	32	6600	3050	1310	3.59	0			0.09	78.58	2.81	4.29	0.72				
	North Mine	10.09.96	4.4	72	6710	3260	1440	3.48	18			0.09	60.41	5.46	3.79	2.30				
		17.09.96	5.5	28	6740	3440	1580	3.60	75			0.03	55.24	6.80	3.41	1.48				
		24.09.96	6.8	52	7080	3320	1390	4.42	56			0.01	47.08	0.06	3.01	0.01				

The shaded figures denote "less than"

Table 3.1c Summary of Weekly Effluent Analyses, September 1996.

Site No.	Sample Source	pH	TSS ppm	TDS ppm	TH ppm	CaH ppm	SO-4 g/l	MAI/Clrds. ppm	Oil ppm	Xant ppm	Cu ppm	Ni ppm	Fe ppm	Mn ppm	Co ppm	Pb ppm	Cd ppm	Hg ppm	Al ppm
1	No.3 Shaft	7.5	54	1958	508	395	0.74	87	0	0	0.01	1.11	0.18	0.27	0.10	0.01	0.01	0.00	0.01
2	No.1 Shaft	5.8	16	3785	1735	1200	1.82	37	0	0.5	0.01	7.01	6.42	1.62	0.27	0.01	0.01	0.01	0.01
3	Main Drain	7.0	43	1118	542	345	0.54	62			0.98	13.68	0.12	0.47	0.35	0.01	0.01	0.01	0.01
4	V-Notch	6.8	8	1070	573	388	0.65	37			0.01	3.71	0.14	0.35	0.21	0.01	0.01	0.01	0.01
5	Tailings Dam	5.5	261	4533	2308	1898	2.59	41			0.03	1.01	9.16	1.20	0.51	0.01	0.01	0.01	0.01
6	Clear Water Dam	2.4	146	8508	3100	1753	4.49	0		0.0	0.28	9.46	551.43	14.29	0.48	0.01	0.01	0.01	0.01
7	Seepage Water	2.6	118	12728	3496	1531	4.89	0		0.0	0.12	12.68	687.00	18.80	0.61	0.01	0.01	0.01	0.01
8	Mathathane River	7.0	15	1560	723	440	0.91	42	1.0	0.2	0.01	2.74	0.30	0.55	0.13	0.01	0.01	0.01	0.01
9	Lethakane River	8.0	27	1470	680	413	0.69	98		0.2	0.01	0.52	0.14	0.07	0.15	0.01	0.01	0.01	0.01
10	3 km Upstream	7.1	30	205	118	78	0.03	125			0.01	0.29	0.14	0.17	0.10	0.01	0.01	0.01	0.01
11	Motloutse/Let.	9.1	109	1518	673	440	0.70	83	1.0	0.0	0.01	0.10	0.21	0.04	0.08	0.01	0.01	0.01	0.01
12	Motloutse 5km	9.1	52	1493	708	475	0.76	80	1.0	0.0	0.01	0.05	0.17	0.02	0.08	0.01	0.01	0.01	0.01
13	Tobane	7.5	276	260	118	80	0.08	84	1.0	0.1	0.01	0.01	0.15	0.14	0.18	0.01	0.01	0.01	0.01
14	Selebi Mine	6.6	62	4450	1788	1305	1.51	51			0.02	40.73	0.30	0.80	1.42				
15	Selebi North	5.1	46	6783	3268	1430	3.75	37			0.06	60.33	3.78	3.63	1.13				

Site	Date	Nickel	Copper	Sulphate
10	25.08.9625.	14.8	8.8	< 1
11		29.1	4.1	< 1
12		16.9	0.68	< 1
13		18.1	11	< 1
10	04.09.96	8.4	5.7	< 1
11		29.8	6	< 1
12		13	5.9	< 1
13		10.8	6.3	< 1
10	11.09.96	16.8	7.1	< 1
11		28.4	3.4	< 1
12		17.4	5	< 1
13		16.9	9	< 1
10	24.09.96	24.1	15.9	< 1
11		124.1	7.8	< 1
12		49.5	6.2	< 1
13		11.3	4.3	< 1

Year/ Month	Site 10			Site 11			Site 12			Site 13			Avg 11/12/13		
	Ni	Cu	SO	Ni	Cu	SO	Ni	Cu	SO	Ni	Cu	SO	Ni	Cu	SO4
90	18	11	22	33	18	116	32	16	70	19	11	32	28	15	73
91	10	7	0	41	26	483	29	16	241	16	10	44	29	17	256
92	11	8	0	27	18	19	22	14	0	13	9	0	21	14	6
93	8	6	0	31	22	56	24	15	0	13	9	0	23	16	19
94	8	6	0	27	22	0	21	16	0	12	9	0	20	16	0
95	9	5	1	21	16	0	18	14	0	12	9	0	16	12	0
Jan	7	3	1	18	7	1	22	8	1	22	13	1	17	8	1
Feb	8	12	1	22	16	1	17	9	1	8	8	1	14	11	1
Mar	15	11	1	31	8	1	27	10	1	17	9	1	22	10	1
Apr	11	4	0	31	5	0	30	6	0	13	4	0	21	5	0
May	25	10	1	34	9	1	40	12	1	17	8	1	29	10	1
June	10	4	1	42	8	1	26	5	1	11	4	1	22	5	1
July	11	8	0	20	16	0	21	16	0	20	16	0	18	14	0
August	14	9	1	53	20	1	36	11	1	15	6	1	30	12	1
Sept.	16	9	1	53	21	1	24	4	1	39	8	1	33	11	1

Table 3.4 Raw Water Consumption and Discharges of Effluent, September '96 (Tonnes per hour)							
Date	Raw Water	Settling Ponds	Lions Club	Million Gallon	Date	Raw Water	Lion's Club
88	786	410			Sept. 1		
89	641	369	328		2	369	200
90	489	286	258		3	353	210
91	456	273	249		4	265	144
92	324	169	141		5	224	90
93	219	41	104		6	378	143
94	270	29	91	23	7		
95	342	76	117	31	8		
Jan96	291	78	170	11	9	399	200
Feb	300	278	346	30	10		
Mar	357	130	140	32	11		
Apr	338	171	164	46	12		
May	426	130	169	30	13		
Jun	426		192		14		
Jul	361		300		15		
Aug	358		174		16	359	160
Sep	347		191		17	307	140
Oct					18	376	180
Nov					19	364	220
Dec					20	355	150
					21		
					22		
					23	367	180
					24	335	160
					25	446	280
					26	311	280
					27	348	320
					28		
					29		
					30		
					Mean	347	191
					Max	446	320
					Min	224	90

4.0 METEOROLOGICAL DATA

Laboratory Barometric Pressure readings and descriptions of the Smelter main stack plume are given in Table 4.1 below.

Mining Department Meteorological data is given in Tables 4.2 and 4.3 overleaf.

Date	Barometric Pressures	Barometric Pressures	Stack Plume Characteristics at:		
	Noon (mm Hg)		07h00	12h00	18h00
1			Looping	Looping	Coning
2	692	923	Looping	Looping	Coning
3	688	917	Looping	Looping	Looping
4	690	920	Looping	Coning	Coning
5	692	923	Looping	Looping	Fanning
6	688	917	Coning	Looping	Coning
7	686		Coning	Looping	Fanning
8					
9	686		Coning	Looping	Coning
10	688	917	Looping	Looping	Looping
11	688	917	Looping	Looping	Looping
12	683	911	Looping	Fumigating	Looping
13	690	920	Looping	Looping	Fumigating
14	688		Coning	Coning	Looping
15					
16	688	917	Coning	Looping	
17	687	916	Looping	Looping	Coning
18	688	917	Coning	Looping	Coning
19	690	920	Coning	Coning	Coning
20	695	927	Coning	Coning	Looping
21	695	927	Coning	Coning	Coning
22					
23	690	920	Looping	Looping	Coning
24	688	917	Coning	Looping	Coning
25	685	913	Looping	Looping	Coning
26	687	916	Coning	Looping	Coning
27	692	923	Looping	Looping	Coning
28	690	920	Coning	Looping	Coning
29					
30					

Table 4.2

**Mining Department Meteorological Observations, 08H00/12H00/16H00,
September 1996**

Date	08h00						12h00			16h00		
	DB	WB	MAX	MIN	RH	Knots	DB	WB	Knots	DB	WB	Knots
1												
2			32.0	13.0			27.0	17.5	05			
3	19.0	14.0	34.0	17.0	56	05	18.8	18.5	05	32.1	20.7	Calm
4	18.0	15.2			74	10	24.8	16.9	08	27.0	18.2	05
5	18.0	14.4	29.0	14.5	67		28.5	21.7	Calm			
6			36.0	15.5						34.8	27.4	05
7	20.4	11.5			29	Calm						
8									05			
9			39.0	16.0			35.7	21.5		36.2	18.2	Calm
10	21.2	13.4	37.5	18.0	37	05	33.2	18.6	05	35.2	19.2	05
11	23.4	16.2	37.0	17.0	45	05	32.6	19.8	05	34.8	18.5	05
12	22.4	13.7	38.0	20.0	34	Calm	35.0	17.5	15	35.4	17.9	12
13	21.6	12.3	32.0	14.0	28	Calm	27.0	14.0	Calm	30.2	14.7	05
14	19.0	10.4			28	Calm	28.5	15.5	Calm			
15			29.0	15.0								
16	18.2	14.3	31.0	15.5	84	15	26.6	19.5	08	29.0	20.5	05
17	21.2	16.5	35.6	21.0	60	Calm						
18	21.4	13.0			84	15	23.6	13.2	20	22.2	11.8	10
19			16.0	15.0			18.0	13.6	05			
20	14.0	12.0	25.0	14.6	79	10	14.6	12.8	20	16.1	14.1	10
21	14.4	13.7			87	05						
22			31.0	20.0								
23	18.3	14.2	27.0	19.5	63	10	22.2	17.7	10	24.6	18.8	10
24	19.5	11.8	32.0	17.0	33	05	28.4	20.1	05	30.7	19.4	05
25	23.4	15.8	33.0	19.0	43	04						
26	24.2	16.4	30.0	18.0	42	04	29.6	24.0	04	35.0	19.0	05
27	22.6	15.2	22.0	18.0	43	05	25.6	18.5	15	33.0	20.5	05
28	22.0	17.0			59	10						
29												
30			34.5	15								

Table 4.3
Wind Directions (% of Time), WEATHER STATION,
August 1996

Wind d'rn	N	NNE	NE	ENE	E	ESE	SE	SSE	Sum
Percent	1.0	1.0	2.0	10.0	34.0	15.0	7.0	6.0	76.0
Wind d'rn	S	SSW	SW	WSW	W	WNW	NW	NNW	Sum
Percent	6.0	3.0	3.0	3.0	3.0	3.0	2.0	1.0	24.0
Total	100								

WIND ROSE - BCL WEATHER STATION
SEPTEMBER 1996

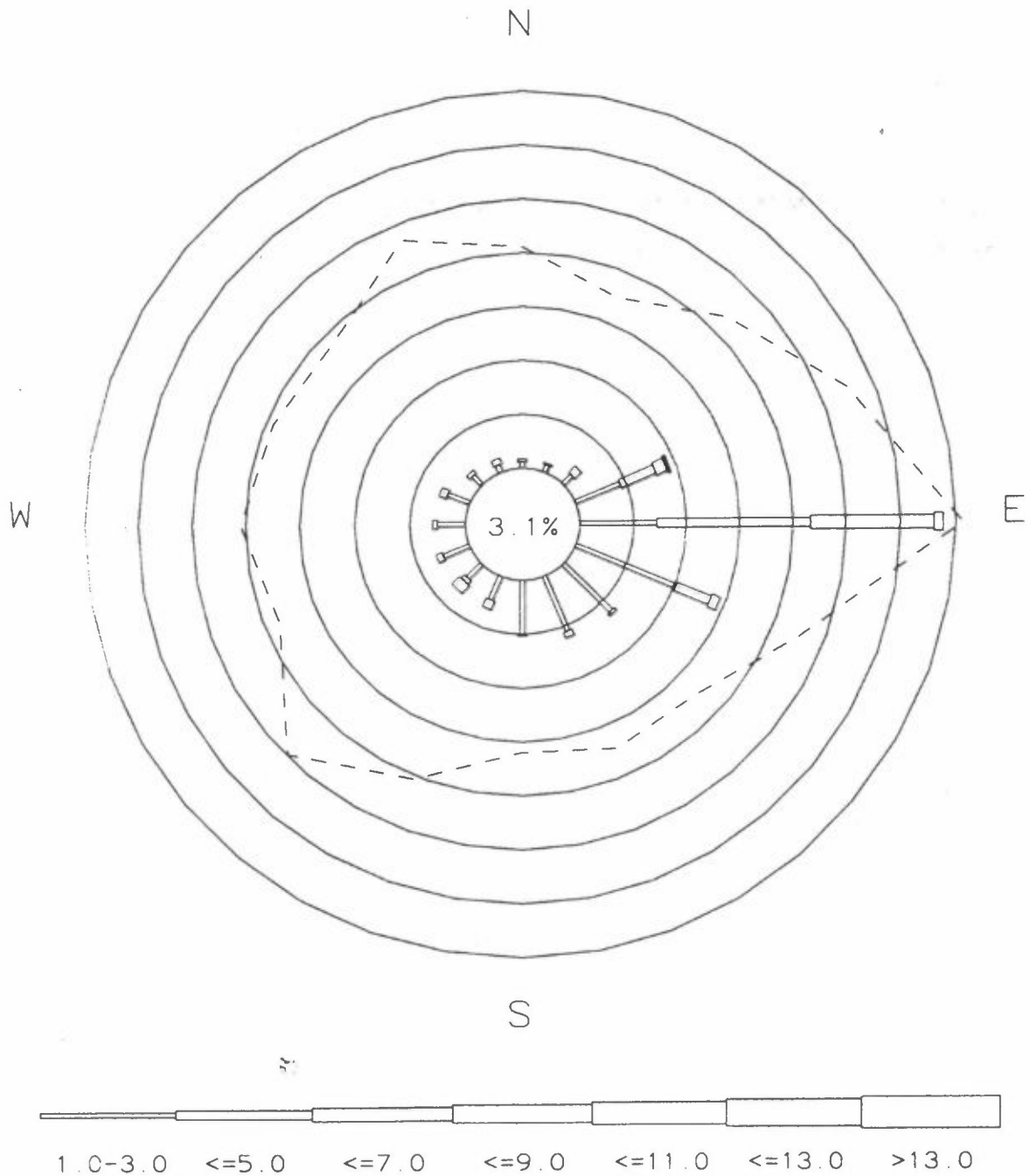

Arcs represent 5% frequency intervals
 Dashed polygon = average values
 Arcs represent 0.6 m/s
 Frequency below minimum shown in inner circle

5.0 PRODUCTION DATA

Production figures for High Grade Matte, Dried Concentrate and Slag are given in table 5.1 below:

Table 5.1 Production of High Grade Matte, Dried Concentrate and Slag; monthly averages from 1992 to September 1996 (tonnes).			
	High Grade Matte	Dried Concentrate	Slag
1992	3952	64769	
1993	4164	66614	67888
1994	4291	60736	64346
1995	4405	60586	65565
January 1996	4392	67345	74053
February	3800	59179	63960
March	5253	68035	78942
April	3967	56833	61632
May	5875	70474	79673
June	5497	70864	80565
July	5142	68721	78887
August	4938	69658	79340
September	4358	74653	64361

Appendix Y

**Reports from the Meteorological Office in
Gaborone**

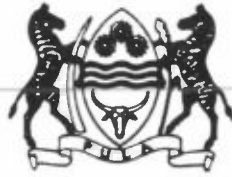

REPUBLIC OF BOTSWANA

DEPARTMENT OF METEOROLOGICAL SERVICES
MINISTRY OF WORKS AND COMMUNICATIONS

Climatological Summaries for Botswana

Issued By

Director of Meteorological Services
P.O. Box 10, 100
Gaborone
Botswana

Price: P1,00

Gaborone
August, 1984

INTRODUCTION

This publication contains basic climatological data for eight synoptic stations in Botswana namely:- Gaborone, Mahalapye, Francistown, Maun, Shakawe, Gantsi, Tshane and Tsabong. The total number of years of record for each element shown in the tables is given at the bottom of each column. The hour to which observations refer is given in local time. The following points may be noted with regard to the various elements.

1. TEMPERATURE: - The mean monthly maximum is the mean of the highest recorded each day. The mean monthly minimum is the mean of the lowest recorded each day. The extreme maximum is the highest ever recorded during the month and likewise the extreme minimum is the lowest ever recorded during the month. The mean monthly temperature is normally taken from the corrected thermograph readings, but as the tabulations of the daily thermographs are not yet completed, the mean monthly temperatures may be derived from the formula:
$$\frac{\text{MAX TEMP} + \text{MIN TEMP}}{2}$$
which is a good approximation for stations in Botswana and generally gives the mean temperature correct to within half a degree celcius.
2. RELATIVE HUMIDITY: - The mean monthly relative humidity at the specified hours is the mean of the daily values at these hours as derived from the readings of the dry and wet-bulb thermometers at the hours.
3. PRECIPITATION: - The first column gives the mean monthly rainfall (mm) during the period of record. The annual mean is the mean of the rainfall recorded in each hydrological year from July to June. The second column gives the maximum rainfall recorded in each month and the third column gives the minimum rainfall recorded in each month during the period in question; the annual figure in these columns indicates the amount of the highest and lowest rainfall recorded during the hydrological years July to June during the period investigated. The fourth column gives the maximum rainfall recorded in 24 hours (beginning with 0800 L.T. and ending with 0800 L.T. the next day) during each month.

The columns five to eight give the mean monthly number of days of rain (a day counted as from 0800 L.T. to 0800 L.T. next day) with 0.1mm or more, 1.0mm or more, 10.0mm or more and 20.0mm or more of rainfall respectively. 'X' indicates a value less than 0.1 but greater than 0.0; annual figures are the totals of the mean monthly values. The percentage variability of rainfall ($\frac{\text{Standard Deviation}}{\text{Mean}} \times 100$) has

Mean

been given only for the main rainy season months of November, December, January, February and March, and for the year as a whole (year taken as from July to June).

4. SUNSHINE: - Mean monthly hours of bright sunshine per day as computed from the records of Campbell - Stokes sunshine recorders in use at the stations, are shown. The annual figure is the mean of the monthly values.
5. EVAPORATION: - Mean monthly values in mm as obtained from the readings of the Class A Evaporation Pans installed at the stations are given. The annual figure is the total of the monthly values.
6. POTENTIAL EVAPOTRANSPIRATION (P.E.T.): - Mean monthly values in mm, as obtained from Penman's formula (1948) for the estimation of potential evapotranspiration from a vegetative cover, have been calculated. The co-efficients a and b used in Angström formula for the estimation of the total radiation from the data of sunshine have been given the values of 0.25 and 0.45, respectively, as recommended by FAO for dry tropical zones, on the basis of field tests. The annual figure is the total of the mean monthly values.
7. PRESSURE: - Mean monthly station level pressures in mb at 0800 L.T., 1400 L.T. and 20 00 L.T. as obtained from the daily readings of mercury barometers (Kew Pattern) in use at the stations are shown. The annual figures are the mean of the mean monthly values.
8. SOIL TEMPERATURE: - Mean monthly values at depths of 10cm, 20cm, and 60cm below ground at 0800, 1400 and 20 00 L.T. have been derived from the daily readings of soil mercury thermometers. The annual figures are the mean of the mean monthly values.

9. WIND: - Mean monthly wind speed has been given in KPH and has been derived from the total daily (0800 L.T. to 0800 L.T. next day) run of a Casella make cup anemometer (height 2m) installed at all stations after deducing the wind speed at the standard height of 10m by use of the following empirical formula

$$V_2 = V_1 \left(\frac{h_2}{h_1} \right)^{0.28}, \quad \text{where } V_1 \text{ and } V_2 \text{ are wind speeds at}$$

heights h_1 and h_2 . The wind direction rose shown in the last column indicates the percentage frequency of wind direction in the eight points of the compass for the year as whole. The percentage frequency of calms (speeds less than 1 knot or 2KPH) is shown in the circle.

10. ELEVATION: - The elevation of the station is given in metres. It is the datum level to which barometer pressure reports at the station refer.

11. Rainfall Charts

The available rainfall data till June 1980 have been used in the preparation of these charts. As the period for different stations is not uniform, the charts may be considered as approximate.

GABORONE

Latitude: 24°40'S; Longitude: 25°55'E; Elevation: 1000m

Month	TEMPERATURE (C°)				RELATIVE HUMIDITY (%)		PRECIPITATION (mm)								Percentage variability of rainfall	Sunshine hrs/day	Evap (mm) Open Tank 'Class A'	P.E.T. (mm) (Penman)
	Mean		Extreme		0800LT	1400LT	Mean	Max	Min	Max 24hr	No of days							
	Max	Min	Max	Min							>0.1	>1.0	>10.0	>20.0				
July	22.3	3.6	29.0	-6.5	67	26	3.5	74.2	0	49.1	0.6	0.3	0.1	x	-	9.7	125	48
August	25.5	6.5	33.1	-3.5	57	24	4.6	34.1	0	23.4	0.8	0.6	0.2	x	-	9.9	177	80
September	29.1	11.9	37.4	-0.6	48	23	14.9	111.3	0	64.0	2.1	1.6	0.6	0.2	-	9.6	247	122
October	30.7	15.5	40.6	2.8	52	29	42.8	142.4	1.8	71.9	6.2	4.7	1.6	0.6	-	9.3	283	155
November	31.2	17.5	39.7	8.5	58	34	64.2	167.8	1.9	96.5	8.3	6.4	2.3	0.8	60	8.8	285	156
December	32.1	18.4	43.9	8.5	61	37	91.6	218.5	0.8	110.0	9.7	7.9	3.1	1.3	62	8.6	302	166
January	32.6	19.7	42.5	10.4	68	41	97.4	324.1	10.4	95.8	10.2	8.4	3.0	1.4	63	8.5	278	161
February	31.2	19.0	39.7	10.9	70	42	84.4	334.4	5.3	192.0	8.9	6.9	2.4	1.4	77	8.5	220	132
March	31.1	18.0	39.7	8.0	71	42	72.7	303.6	5.3	169.9	7.4	5.8	2.1	1.0	77	8.1	223	124
April	27.2	13.1	35.6	-2.2	75	41	43.7	266.8	0	74.2	5.8	4.4	1.4	0.6	-	8.3	167	85
May	24.6	7.6	33.9	-2.2	73	33	13.7	82.3	0	47.0	2.6	2.1	0.4	0.1	-	9.1	140	63
June	22.2	4.0	30.2	-5.0	72	28	4.6	43.8	0	30.7	0.8	0.5	0.1	x	-	8.5	104	44
Annual	28.3	12.9	43.9	-6.5	64	33	538.1	925.3	292.8	192.0	63.4	49.6	17.3	7.4	29	8.9	2,551	1,336
Record (Years)	(1958-80)	(1948-80)	(1962-79)				(1922-80)				(1926-80)			(1922-80)	(1958-80)	(1956-75)	(1958-75)	

GABORONE (Contd.)

Month	Mean Station Level Pressure (mb)			SOIL TEMPERATURES (C°)									Mean Wind Speed (km/hr)	Wind Direction Rose (Annual) (% Frequencies)
	0800	1400	2000	0800			1400			2000				
				10cm	20cm	60cm	10cm	20cm	60cm	10cm	20cm	60cm		
July	910.1	908.1	907.9	11.3	13.8	17.5	18.0	15.7	16.8	17.7	17.8	16.9	5.0	
August	908.4	906.1	906.1	14.0	16.5	19.0	21.0	18.6	18.7	21.5	21.1	18.9	6.4	
September	906.7	903.9	904.2	18.8	21.2	22.9	26.3	23.2	23.2	25.6	26.0	23.4	7.8	
October	904.7	902.0	901.8	22.0	24.4	26.4	30.5	27.5	26.2	29.3	29.5	26.3	9.1	
November	903.7	901.1	900.7	24.5	26.7	28.5	32.5	30.1	28.0	30.9	31.9	28.5	8.2	
December	902.4	900.2	899.5	25.2	27.6	29.5	33.1	31.0	29.2	31.5	33.9	29.5	7.2	
January	902.2	900.5	899.7	26.1	28.6	30.7	33.2	31.6	30.3	32.5	30.4	30.4	6.9	
February	902.3	900.9	900.1	25.5	27.3	30.4	33.1	30.7	29.9	31.6	32.8	30.1	5.9	
March	904.6	902.6	901.6	24.2	26.4	29.1	31.7	29.3	28.4	30.8	31.5	29.1	5.0	
April	905.7	903.7	903.7	19.9	22.3	25.5	26.8	24.6	25.0	26.0	26.5	25.3	4.8	
May	907.6	905.6	906.0	15.3	17.8	21.8	22.4	20.3	21.0	21.6	22.3	21.5	5.1	
June	909.1	907.9	908.1	12.2	14.4	17.9	18.1	16.1	16.0	18.1	18.4	17.8	4.8	
Annual	905.6	903.6	903.3	19.9	22.3	24.9	27.2	24.9	24.4	26.4	26.8	24.8	6.4	
Record (Years)	(1963-1979)						(1958-1979)				(1958-80)			(1968-73)

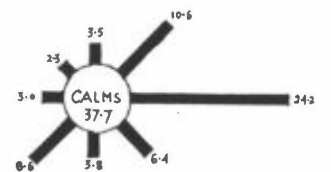

(0500+0800+1100+1400+1700+2000 hrs)

MAHALAPYE

Latitude: 23°05'S; Longitude: 26°46'E; Elevation: 1006m

Month	TEMPERATURE (C°)				RELATIVE HUMIDITY (%)			PRECIPITATION (mm)					Percentage variability of rainfall	Sunshine hrs/day	Evap (mm) Open Tank 'Class A'	P.E.T. (mm) (Penman)		
	Mean		Extreme		0800LT	1400LT	Mean	Max	Min	Max 24hr	No of days							
	Max	Min	Max	Min							>0.1	>1.0					>10.0	>20.0
July	22.3	3.9	29.8	- 4.0	54	33	2.4	63.6	0	19.1	0.5	0.3	x	x	-	9.7	117	48
August	25.1	7.1	34.1	- 6.0	55	31	2.7	48.1	0	22.6	0.5	0.4	x	x	-	9.1	152	76
September	29.2	12.6	37.6	1.7	50	30	8.0	61.0	0	24.7	1.4	1.1	0.3	x	-	8.8	207	113
October	29.8	15.6	39.3	6.2	52	38	29.8	105.4	0	63.0	4.3	3.2	0.9	0.4	-	8.4	271	137
November	30.4	18.0	38.6	8.6	60	47	66.0	171.5	0	74.6	7.6	6.2	2.2	1.1	65	7.6	246	138
December	30.6	19.0	37.9	11.6	60	44	81.2	255.0	6.0	116.8	8.4	7.2	2.7	1.3	73	8.6	252	153
January	30.9	19.1	40.5	12.5	58	47	91.7	287.7	5.3	93.4	9.8	8.3	3.0	1.4	75	6.8	252	142
February	30.2	19.2	36.6	13.5	64	54	78.8	373.4	2.0	176.0	8.2	6.8	2.6	1.1	87	7.1	208	120
March	28.6	16.6	36.5	9.8	68	54	64.1	257.2*	0.6	130.1	6.7	5.5	2.0	1.0	81	7.8	210	112
April	26.5	13.2	34.6	4.5	64	44	24.6	125.0	0	121.9	3.2	2.5	0.8	0.3	-	8.6	157	83
May	24.4	8.1	33.0	1.0	62	35	10.6	100.5	0	28.2	1.9	1.5	0.4	x	-	8.7	133	61
June	22.1	4.9	28.9	- 5.4	64	42	3.2	49.8	0	36.8	0.5	0.4	0.1	x	-	8.7	102	44
Annual	27.5	13.1	40.5	- 6.0	59	42	462.7	891.3	143.9	176.0	53.0	43.4	15.0	6.6	35	8.3	2,307	1,227
Record (Years)	(1961-80)	(1961-80)	(1959-79)				(1912-1980)				(1912-1980)				(1912-80)	(1975-80)	(1959-69)	(1975-80)

*1984

MAHALAPYE (Contd.)

Month	Mean Station Level Pressure (mb)			SOIL TEMPERATURES (C°)									Mean Wind Speed (km/h)	Wind Direction Rose (Annual) (% Frequencies)	
	0800	1400	2000	0800			1400			2000					
				10cm	20cm	60cm	10cm	20cm	60cm	10cm	20cm	60cm			
July	912.0	910.0	909.9	11.9	14.3	18.0	19.9	16.7	17.9	18.8	18.7	17.7	3.5		
August	908.7	906.2	906.7	15.8	17.5	19.8	22.9	19.6	19.8	22.5	21.7	19.9	4.6		
September	907.5	904.6	905.6	21.0	22.8	23.5	28.3	24.9	23.4	26.4	26.6	23.6	5.9		
October	905.2	902.6	903.1	23.5	25.0	26.8	31.9	28.7	26.8	30.4	30.6	26.7	6.9		
November	905.2	902.9	902.9	25.0	26.6	28.1	32.5	29.9	27.9	30.1	31.1	28.1	6.2		
December	903.6	901.4	901.4	26.5	28.7	30.2	34.7	32.4	29.7	32.2	34.4	29.7	5.6		
January	903.0	901.0	901.6	27.8	28.7	30.2	33.8	31.4	30.1	32.1	30.0	30.2	5.3		
February	903.3	901.5	901.3	25.4	27.4	28.9	32.4	30.3	28.5	29.9	31.8	28.5	4.6		
March	905.4	903.5	903.4	24.0	26.1	27.9	31.5	29.1	27.8	29.2	30.4	27.5	4.3		
April	907.1	904.9	905.4	20.7	23.4	25.7	28.2	25.9	25.6	25.5	28.0	25.6	3.8		
May	907.8	905.7	906.5	15.9	19.2	22.5	23.7	21.7	22.3	21.2	22.9	22.0	3.4		
June	910.6	909.6	909.5	13.0	15.6	19.1	19.7	19.0	18.9	16.2	20.3	18.3	3.8		
Annual	906.6	904.5	904.8	20.9	22.9	25.1	28.3	25.8	24.9	26.2	27.2	24.8	4.8		
Record (Years)		(1977-1979)					(1968-1980)						(1959-80)		(1965-69)

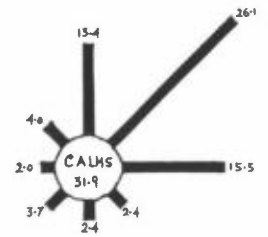

(0800+1400+2000 hrs)

FRANCISTOWN

Latitude: 21°13'S; Longitude: 27°30'E; Elevation: 1000m

Month	TEMPERATURE (C°)				RELATIVE HUMIDITY (%)		PRECIPITATION (mm)								Percentage variability of rainfall	Sunshine hrs/day	Evap (mm) Open Tank 'Class A'	P.E.T. (mm) (Penman)
	Mean		Extreme		0800LT	1400LT	No of days											
	Max	Min	Max	Min			Mean	Max	Min	Max 24hr	≥ 0.1	≥ 1.0	≥ 10.0	≥ 20.0				
July	23.1	4.8	30.6	- 5.0	70	29	0.5	11.4	0	11.4	0.2	0.1	x	0	-	9.6	186	70
August	25.1	7.7	35.5	- 4.2	60	26	1.2	14.3	0	10.5	0.2	0.2	x	0	-	9.9	236	104
September	29.8	12.3	37.0	1.5	51	27	6.5	69.4	0	39.4	1.0	0.6	0.1	x	-	9.6	290	151
October	31.5	16.2	40.2	4.0	56	32	27.0	125.8	0	60.2	3.6	2.6	1.0	0.2	-	9.0	344	181
November	31.0	16.9	41.1	4.1	59	41	56.4	164.0	0	66.6	6.9	5.8	2.0	0.7	70	8.1	305	168
December	30.3	18.5	39.5	8.8	68	44	94.6	252.3	2.8	104.2	8.8	7.8	3.3	1.3	67	7.4	304	158
January	30.7	19.0	40.6	10.6	69	48	105.7	364.4	0	115.8	8.8	7.8	3.1	1.7	82	8.0	272	158
February	29.5	16.2	38.4	10.5	74	50	85.6	271.9	0	87.8	7.5	6.5	2.6	1.3	80	8.2	256	132
March	29.3	16.9	38.8	4.0	72	46	61.6	246.8	0	116.8	6.2	4.8	1.9	1.0	101	8.2	261	134
April	27.7	13.7	35.6	4.0	74	41	23.3	75.4	0	60.5	3.0	2.1	0.7	0.3	-	8.5	222	102
May	25.6	8.5	34.0	- 1.0	72	32	7.4	75.9	0	43.0	1.3	1.0	0.2	x	-	9.4	221	82
June	23.0	5.3	31.1	- 4.5	67	34	2.9	36.0	0	27.9	0.5	0.2	x	x	-	8.9	176	62
Annual	28.1	13.2	41.1	- 5.0	66	38	472.6	897.9	114.1	116.8	48.0	39.5	14.9	6.5	39	8.7	3,073	1,502
Record (Years)	(1959-80)		(1959-80)		(1960-79)		(1921-1980)				(1921-1980)				(1921-80)	(1958-80)	(1958-73)	(1960-79)

FRANCISTOWN (Contd.)

Month	Mean Station Level Pressure (mb)			SOIL TEMPERATURES (C°)									Mean Wind Speed (km/hr)	Wind Direction Rose (Annual) (% Frequencies)
	0800	1400	2000	0800			1400			2000				
				10cm	20cm	60cm	10cm	20cm	60cm	10cm	20cm	60cm		
July	910.0	908.1	908.3	13.5	16.9	19.8	21.6	18.5	19.7	20.0	19.1	19.6	8.6	
August	908.3	906.1	906.7	17.1	19.4	21.2	23.8	20.3	21.2	23.3	22.2	21.2	10.2	
September	906.6	903.7	904.6	21.2	23.0	23.9	28.2	24.4	24.2	27.3	26.0	24.2	12.8	
October	904.7	901.7	902.7	24.3	26.6	26.9	32.7	27.8	27.1	31.1	29.7	27.7	14.4	
November	903.9	901.0	901.8	24.6	26.9	28.3	34.3	28.8	28.2	30.9	30.2	28.3	12.6	
December	902.7	900.1	900.6	25.5	27.3	28.6	32.5	28.9	28.8	30.5	30.4	28.8	11.4	
January	901.8	899.9	898.7	27.0	27.8	29.7	33.0	29.6	29.4	32.3	31.2	29.6	10.9	
February	902.0	900.2	900.2	25.7	27.0	28.6	30.9	29.0	28.7	30.3	29.8	28.6	10.7	
March	904.4	902.2	902.4	23.2	26.3	28.2	31.3	28.0	30.3	29.9	29.5	27.2	10.7	
April	905.6	903.6	904.4	22.3	24.5	26.3	28.0	25.4	26.6	26.8	28.2	26.6	9.1	
May	907.7	905.4	906.6	18.9	21.1	23.5	24.4	21.5	23.7	23.8	23.3	23.4	7.8	
June	909.6	907.4	908.4	15.1	18.2	20.6	20.7	18.5	20.7	20.0	20.0	20.7	7.8	
Annual	905.6	903.3	903.8	21.5	23.8	25.5	28.5	25.1	25.7	27.2	26.6	25.5	10.6	
Record (Years)	(1960-1979)			(1958-1979)									(1956-80)	(1969-1978)

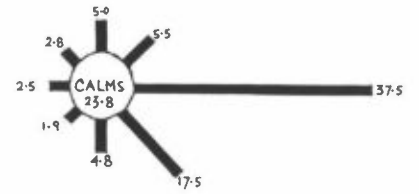

(0800+1400+2000 hrs)

Month	TEMPERATURE (C°)				RELATIVE HUMIDITY (%)		PRECIPITATION (mm)								Percentage variability of rainfall	Sunshine hrs/day	Evap (mm) Open Tank 'Class A'	P.E.T. (mm) (Penman)
	Mean		Extreme		0800LT	1400LT	No of days											
	Max	Min	Max	Min			Mean	Max	Min	Max 24hr	>0.1	>1.0	>10.0	>20.0				
July	25.1	6.9	31.3	-3.6	62	25	0.1	5.8	0	3.5	x	x	x	0	-	9.8	163	86
August	28.3	9.8	35.2	3.5	52	20	0.8	27.6	0	18.0	0.2	0.2	x	0	-	10.3	218	119
September	32.2	14.6	38.6	3.9	40	19	2.5	29.2	0	25.8	0.6	0.3	x	x	-	10.1	263	167
October	34.1	18.6	41.4	9.0	44	23	15.7	99.7	0	54.6	3.2	2.4	0.4	0.2	-	9.5	307	200
November	33.0	19.4	41.7	9.4	57	32	49.1	169.6	0.8	54.4	7.1	5.3	1.6	0.5	75	8.6	256	176
December	32.1	19.4	40.6	8.4	69	42	79.2	264.0	13.0	71.1	9.8	7.8	2.8	1.2	64	8.3	235	169
January	31.6	19.5	40.0	9.2	76	48	113.7	395.9	17.9	101.8	11.7	9.6	3.6	1.8	62	8.0	236	158
February	31.4	18.9	37.2	10.6	78	48	106.1	365.7	11.2	139.5	11.1	9.1	3.4	1.5	78	8.1	209	136
March	31.3	17.8	39.5	6.2	75	42	76.2	273.8	0	120.4	8.1	6.6	2.4	1.0	91	8.5	212	142
April	29.9	15.0	35.0	4.4	70	36	26.5	120.4	0	46.8	3.9	3.1	0.8	0.3	-	9.1	199	114
May	27.5	9.6	33.0	-1.1	64	27	6.1	64.3	0	23.9	1.0	0.8	x	x	-	10.0	189	95
June	25.0	6.9	30.6	-5.8	64	27	0.9	17.1	0	15.5	0.2	0.2	x	0	-	9.5	158	76
Annual	30.1	14.7	41.7	-5.8	63	32	476.8	1183.9	193.0	139.5	56.9	45.4	15.0	6.5	38	9.2	2,665	1,638
Record (Years)	(1959-80)	(1941-80)	(1964-79)				(1921-80)				(1926-80)				(1921-80)	(1959-80)	(1958-76)	(1967-80)

MAUN (Contd.)

Month	Mean Station Level Pressure (mb)			SOIL TEMPERATURES (C°)									Mean Wind Speed (km/hr)	Wind Direction Rose (Annual) (% Frequencies)	
	0800	1400	2000	0800			1400			2000					
				10cm	20cm	60cm	10cm	20cm	60cm	10cm	20cm	60cm			
July	917.7	917.0	916.7	13.4	17.4	19.6	22.7	19.0	19.7	20.7	19.9	19.5	9.6		
August	916.1	915.1	914.2	16.7	19.8	21.7	25.9	21.7	21.3	23.7	23.0	21.4	10.4		
September	914.2	912.4	912.0	20.9	23.7	24.7	30.9	25.7	24.7	28.4	27.3	24.7	12.3		
October	912.7	910.7	910.4	25.0	27.4	27.7	34.6	29.9	28.3	31.5	30.9	28.3	13.8		
November	912.4	910.8	909.6	25.4	27.7	28.6	36.0	30.9	29.1	33.3	31.7	29.2	12.1		
December	911.4	910.0	909.0	25.7	26.5	28.8	34.1	30.5	26.9	31.2	30.6	29.2	10.7		
January	910.6	909.6	908.5	25.4	27.3	28.7	34.6	31.1	29.3	30.6	31.5	29.7	9.4		
February	910.4	910.1	908.6	24.7	26.2	28.2	32.9	29.7	28.3	29.4	30.1	28.5	9.0		
March	912.4	911.9	910.1	23.8	25.8	28.0	32.5	29.3	28.2	29.7	30.4	28.1	9.4		
April	914.0	913.3	912.5	21.7	23.5	26.2	30.6	27.2	26.6	27.5	27.9	26.8	8.9		
May	915.6	914.8	914.7	17.3	19.7	23.1	26.1	22.9	24.0	23.9	24.4	23.8	8.6		
June	917.5	916.8	916.6	14.1	17.6	20.5	22.3	19.2	20.2	20.2	20.3	20.1	9.1	(0500+0800+1100+1400+1700+2000 hrs)	
Annual	913.8	912.7	911.9	21.2	23.6	25.5	30.3	26.4	25.7	27.5	27.4	25.8	10.3		
Record (Years)	(1966-1979)			(1966-1979)			(1966-1979)				(1967-80)			(1966-79)	

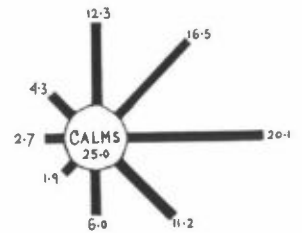

Month	TEMPERATURE (C°)				RELATIVE HUMIDITY (%)		PRECIPITATION					No of days				Percentage variability of rainfall	Sunshine hrs/Day	Evap (mm) Open Tank	P. E. T. (mm)
	Mean		Extreme		0800LT	1400LT	Mean	Max	Min	Max 24hr	0.1	1.0	10.0	20.0					
	Max	Min	Max	Min															
July	24.8	6.0	31.9	- 6.1	68	25	0	0	0	0	x	0	0	0	-	9.7	161	61	
August	28.6	8.6	34.7	- 5.5	59	21	0.1	2.3	0	2.3	x	x	0	0	-	10.1	190	92	
September	32.3	12.5	38.0	2.0	51	22	3.3	44.1	0	26.0	0.7	0.4	0.1	x	-	10.3	241	122	
October	34.3	17.1	39.5	2.0	51	28	13.4	66.5	0	41.5	2.5	1.8	0.4	0.1	-	9.0	277	151	
November	32.8	18.4	39.6	10.0	64	36	53.2	291.5	0	100.5	7.0	6.4	2.3	1.1	95	6.0	262	144	
December	31.4	19.0	39.1	11.4	74	46	99.1	235.8	20.1	58.5	10.7	10.0	4.9	2.7	53	7.6	262	146	
January	30.4	19.3	39.2	10.6	80	55	135.1	368.9	25.7	75.0	11.7	10.9	5.4	2.8	63	7.1	229	136	
February	30.4	19.2	36.6	11.3	82	53	129.6	292.1	12.4	65.0	10.0	9.4	4.3	2.3	65	7.3	211	120	
March	30.2	18.5	36.4	8.8	75	50	71.9	185.7	0	57.6	7.9	7.1	3.1	1.6	80	8.0	223	124	
April	29.4	16.0	36.0	7.0	74	41	24.9	134.3	0	56.3	2.8	2.6	0.9	0.2	-	8.8	192	100	
May	27.4	10.8	32.6	0.4	65	30	2.5	17.8	0	15.5	0.6	0.5	x	0	-	9.8	178	79	
June	25.0	6.5	30.6	- 7.5	71	28	0.4	11.3	0	8.3	0.1	x	0	0	-	9.3	146	57	
Annual	29.8	14.3	39.6	- 7.5	69	36	533.5	1091.4	234.9	100.5	54.0	49.1	21.4	10.8	36	8.8	2,572	1,332	
Record (Years)	(1959-80)	(1959-80)	(1965-79)				(1932-80)				(1932-80)			(1930-80)		(1965-80)	(1961-69)	(1965-79)	

SHAKAWÉ (Contd.)

Month	Mean Station Level Pressure (mb)			SOIL TEMPERATURES (C°)									Mean Wind Speed (km/hr)	Wind Direction Rose (Annual) (% Frequencies)
	0800	1400	2000	0800			1400			2000				
				10cm	20cm	60cm	10cm	20cm	60cm	10cm	20cm	60cm		
July	907.9	906.2	905.8	14.7	20.0	21.4	24.4	20.8	22.0	23.5	22.8	22.3	3.5	<p>(0800+1400+2000 hrs)</p>
August	905.9	904.0	904.3	18.3	21.3	23.3	27.9	22.3	23.9	26.9	25.3	24.0	5.0	
September	904.1	901.9	902.0	24.3	25.9	26.2	31.0	29.3	26.6	24.0	30.9	26.9	5.3	
October	902.4	899.6	898.8	24.5	28.5	28.8	34.5	32.3	29.7	32.9	33.3	29.7	5.7	
November	902.1	900.0	900.2	25.8	28.2	29.9	30.6	32.6	30.4	31.6	33.3	30.9	5.0	
December	901.0	899.1	898.7	25.3	27.3	28.6	29.0	32.9	30.9	30.4	33.8	30.2	5.4	
January	900.3	898.6	898.6	24.9	29.3	28.8	32.3	29.8	29.5	29.6	31.8	30.4	5.3	
February	900.3	898.6	898.9	25.2	26.6	28.9	32.2	30.4	29.9	30.5	31.7	30.5	5.1	
March	902.3	900.6	900.6	25.9	25.5	29.1	33.6	29.5	29.7	32.0	30.3	29.5	5.1	
April	903.8	902.1	902.3	24.2	23.4	28.1	31.7	27.3	28.8	30.5	29.0	29.4	4.3	
May	905.9	904.1	904.4	20.0	21.6	25.4	27.9	23.2	25.7	22.8	24.4	26.1	3.8	
June	907.5	905.9	906.5	16.3	18.8	22.5	24.2	20.8	23.0	23.3	23.7	23.3	3.7	
Annual	903.6	901.7	901.8	22.5	24.7	26.8	29.9	27.6	27.5	28.2	29.2	27.8	4.8	
Record (Years)	(1965-1979)			(1965-1980)									(1960-80)	(1964-69)

GANTSI

Latitude: 21°42'S; Longitude: 21°39'E; Elevation: 1100m

Month	TEMPERATURE (C°)				RELATIVE HUMIDITY (%)			PRECIPITATION (mm)							Percentage variability of rainfall	Sunshine hrs/day	Evap (mm) Open Tank 'Class A'	P.E.T. (mm) (Penman)
	Mean		Extreme		0800LT	1400LT	Mean	No of days										
	Max	Min	Max	Min				>0.1	>1.0	>10.0	>20.0							
July	24.0	4.1	29.8	- 8.5	63	29	0.5	11.7	0	9.1	0.2	0.1	0	0	-	9.9	189	72
August	26.8	7.0	34.5	- 5.4	54	26	0.5	6.7	0	6.3	0.3	x	0	0	-	10.4	249	102
September	30.8	11.5	37.2	- 1.1	45	25	2.8	41.2	0	29.0	1.0	0.5	x	x	-	9.9	302	145
October	33.2	15.8	40.6	3.5	48	27	20.3	110.4	0.6	82.4	3.9	2.7	0.6	0.2	-	9.4	354	186
November	32.8	17.8	41.3	5.0	55	32	47.3	115.2	0	56.1	7.3	5.7	1.7	0.5	61	8.5	331	179
December	32.9	12.5	40.0	6.2	63	37	66.1	146.0	6.3	81.0	9.1	6.9	2.2	0.9	60	9.4	326	187
January	31.6	19.0	40.3	6.5	72	47	100.5	388.4	11.4	231.0	10.5	8.5	3.1	1.3	79	8.1	303	162
February	31.3	18.3	39.6	5.5	75	46	84.4	226.8	8.1	124.2	9.3	7.6	2.6	1.2	65	7.9	263	136
March	30.9	16.8	38.8	3.5	74	43	70.2	274.4	2.6	108.0	7.5	6.1	2.4	1.1	87	8.4	274	140
April	28.7	14.0	36.4	0.3	74	40	35.7	159.2	0	52.1	4.6	3.7	1.3	0.4	-	8.5	207	101
May	26.2	8.2	34.5	- 2.2	69	33	8.7	97.1	0	52.8	1.7	1.3	0.2	x	-	9.7	194	80
June	23.3	4.7	29.8	- 8.1	70	35	0.8	11.4	0	11.4	0.4	0.1	x	0	-	8.9	170	60
Annual	29.4	13.0	41.3	- 8.5	64	35	437.7	926.1	122.2	231.0	55.8	43.2	14.1	5.6	37	9.1	3,162	1,550
Record (Years)	(1959-80)	(1959-80)	(1965-79)	(1965-79)	(1922-80)	(1922-80)	(1922-80)	(1922-80)	(1922-80)	(1922-80)	(1922-80)	(1922-80)	(1922-80)	(1922-80)	(1922-80)	(1965-80)	(1961-76)	(1965-79)

GANTSI (Contd.)

Month	Mean Station Level Pressure (mb)			SOIL TEMPERATURES (C°)									Mean Wind Speed (km/hr)	Wind Direction Rose (Annual) (% Frequencies)				
	0800	1400	2000	0800			1400			2000								
				10cm	20cm	60cm	10cm	20cm	60cm	10cm	20cm	60cm						
July	898.6	896.8	897.1	12.4	15.3	18.2	19.8	16.9	18.0	19.3	18.9	18.2	9.0					
August	896.7	894.7	894.8	14.3	17.8	19.7	22.7	19.3	19.6	22.8	21.4	19.9	9.6					
September	894.9	892.4	892.5	19.3	21.5	22.8	26.7	23.0	22.7	27.0	25.3	22.9	11.2					
October	893.2	890.5	890.7	22.7	25.7	25.9	31.4	27.4	25.9	30.6	29.4	26.0	12.6					
November	892.2	889.7	889.6	24.0	26.2	27.5	33.1	29.6	27.3	30.8	30.7	27.7	12.5					
December	891.4	889.1	889.5	24.9	27.5	28.1	33.2	30.1	28.2	31.1	31.6	28.6	11.2					
January	891.1	889.1	888.6	24.4	26.9	28.4	31.9	29.8	27.9	30.3	31.4	29.7	10.4					
February	891.1	889.3	888.8	23.2	25.7	27.7	30.5	28.7	27.5	29.8	30.2	28.0	9.8					
March	892.9	891.0	891.2	22.9	24.8	27.2	29.8	27.6	27.0	29.6	29.4	27.5	9.4					
April	894.3	892.6	892.8	19.6	22.5	25.0	28.0	25.4	24.8	26.0	27.1	25.2	7.5					
May	896.3	894.5	895.0	16.4	18.9	21.9	24.1	21.2	21.8	22.3	23.0	22.1	7.5					
June	898.2	896.4	897.0	13.1	15.6	19.2	20.2	17.3	19.0	19.2	18.8	19.0	7.8					
Annual	894.2	892.2	892.3	19.8	22.4	24.3	27.6	24.7	24.1	26.6	26.4	24.6	9.9					
Record (Years)	(1964-1980)	(1964-1980)	(1964-1980)	(1965-1980)	(1965-1980)	(1965-1980)	(1965-1980)	(1965-1980)	(1965-1980)	(1965-1980)	(1965-1980)	(1965-1980)	(1965-1980)	(1965-1980)	(1965-1980)	(1965-1969)	(1965-1969)	(1965-1969)

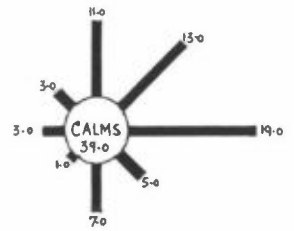

(0800+1400+2000 hrs)

TSHANE

Latitude: 24°01'S; Longitude: 21°53'E; Elevation: 1100m

Month	TEMPERATURE (C°)				RELATIVE HUMIDITY (%)		PRECIPITATION (mm)								Percentage variability of Rainfall	Sunshine hrs/day	Evap (mm) Open Tank 'Class A'	P. E. T. (mm) (Penman)
	Mean		Extreme		0800LT	1400LT	Mean	Max	Min	Max 24hr	No of days							
	Max	Min	Max	Min							>0.1	>1.0	>10.0	>20.0				
July	22.2	3.5	31.9	- 5.0	66	32	1.1	24.8	0	13.3	0.2	0.2	x	0	-	9.8	186	60
August	25.2	6.0	32.6	- 8.0	58	30	0.5	6.7	0	4.5	0.2	0.2	0	0	-	9.9	220	93
September	29.4	11.2	37.8	- 3.9	49	26	2.8	20.8	0	9.4	1.2	0.7	x	0	-	9.6	294	137
October	31.6	14.2	39.9	4.9	51	28	16.0	67.1	0	29.4	3.3	2.3	0.6	0.1	-	9.9	325	175
November	33.0	16.9	39.4	7.0	53	31	30.4	137.8	5.2	42.8	5.8	4.6	1.0	0.1	92	10.2	321	194
December	33.7	18.3	40.8	6.0	57	32	33.8	94.6	3.1	37.9	6.1	4.7	1.2	0.4	73	9.6	369	203
January	33.3	19.3	41.0	10.5	65	42	86.0	239.0	11.3	110.0	8.1	7.2	2.8	1.2	82	8.9	378	182
February	32.0	18.6	38.7	11.0	72	43	72.3	221.2	3.5	149.6	8.3	6.1	2.1	1.0	87	8.1	303	144
March	30.6	17.1	38.9	5.7	71	42	68.5	207.8	0.3	105.0	6.7	5.2	1.9	1.0	94	9.3	287	135
April	27.6	13.0	34.5	3.6	74	43	34.8	98.7	1.1	54.7	5.3	3.8	1.0	0.6	-	8.4	253	97
May	24.5	7.0	34.5	- 0.5	70	35	7.4	31.2	0	21.0	2.0	1.2	0.1	x	-	9.7	225	72
June	21.6	3.9	29.5	- 6.4	70	35	3.6	25.4	0	25.0	0.5	0.4	x	x	-	9.5	187	51
Annual	28.7	12.4	41.0	- 8.0	63	35	357.2	756.7	145.2	149.6	47.7	36.6	10.7	4.4	47	9.4	3,348	1,543
Record (Years)	(1959-80)	(1959-80)	(1965-79)				(1958-1980)				(1958-1980)				(1958-80)	(1965-80)	(1961-74)	(1965-80)

TSHANE (Contd.)

Month	Mean Station Level Pressure (mb)			SOIL TEMPERATURES (C°)									Mean Wind Speed (km/hr)	Wind Direction Rose (Annual) (% Frequencies)
	0800	1400	2000	0800			1400			2000				
				10cm	20cm	60cm	10cm	20cm	60cm	10cm	20cm	60cm		
July	897.5	896.0	896.2	11.8	13.2	17.4	17.5	17.4	17.3	16.4	16.4	17.2	8.3	
August	895.4	893.7	893.7	14.2	15.7	18.8	21.4	19.7	18.6	18.7	19.1	18.8	9.8	
September	894.5	892.2	892.5	17.8	19.1	21.8	26.1	24.5	21.7	23.4	22.1	21.6	11.2	
October	892.1	889.8	889.8	22.3	23.1	25.2	31.1	29.8	25.2	29.2	28.0	25.3	12.0	
November	891.2	888.9	888.7	25.0	25.9	29.8	33.7	31.8	28.1	31.7	30.7	27.9	12.3	
December	889.9	888.0	887.4	26.9	27.3	29.8	35.0	32.7	29.5	33.1	31.6	29.4	12.2	
January	889.7	888.0	887.3	27.4	27.7	30.4	35.4	33.2	30.2	34.1	32.0	30.2	11.8	
February	890.1	888.6	887.9	26.9	26.6	29.4	33.8	31.8	29.4	32.9	32.2	29.4	10.4	
March	892.1	890.5	890.0	24.5	25.3	28.1	32.9	31.2	28.4	31.3	30.3	28.5	9.9	
April	893.5	891.7	891.7	20.2	21.0	25.5	28.3	27.2	25.5	26.0	25.6	25.5	8.5	
May	895.4	893.7	894.0	15.4	16.1	21.7	22.8	22.2	21.6	21.7	20.9	21.7	7.8	
June	896.8	895.4	895.8	12.1	13.2	18.4	19.4	18.2	18.3	17.7	17.3	18.5	7.8	
Annual	893.2	891.4	891.3	20.4	21.2	24.7	28.1	26.6	24.5	26.4	25.5	24.5	10.2	
Record (Years)		(1960-1980)				(1960-1980)						(1959-80)		(1979-83)

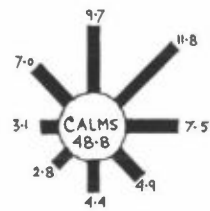

(0800+1400+2000 hrs)

TSABONG

Latitude: 26°03'S; Longitude: 22°27'E; Elevation: 1000m

Month	TEMPERATURE (C°)				RELATIVE HUMIDITY (%)		PRECIPITATION (mm)								Percentage variability of Rainfall	Sunshine hrs/day	Evap (mm) Open Tank 'Class A'	P.E.T. (mm) (Penman)
	Mean		Extreme		0800LT	1400LT	Mean	Max	Min	Max 24hr	No of days							
	Max	Min	Max	Min							>0.1	≥1.0	≥10.0	≥20.0				
July	22.0	1.3	28.9	-10.6	72	27	1.4	17.8	0	8.4	0.5	0.3	0	0	-	8.8	113	50
August	24.3	3.5	32.6	-15.2	61	24	2.2	18.0	0	10.7	0.6	0.7	x	0	-	9.9	166	81
September	28.8	8.1	38.5	-6.7	46	19	6.9	39.0	0	60.0	0.7	0.6	0.3	0.1	-	9.9	221	123
October	31.2	12.3	39.6	-1.1	48	23	14.5	60.8	0	34.4	2.3	1.9	0.5	0.2	-	10.5	281	163
November	33.4	15.9	42.6	1.8	47	23	25.1	130.7	0	34.5	3.9	2.9	0.9	0.3	110	10.8	288	184
December	34.5	17.7	41.1	6.1	49	25	34.8	140.3	0	74.7	5.1	3.8	1.1	0.5	93	10.7	355	210
January	34.4	19.0	42.1	6.7	58	32	52.9	301.3	0.7	213.4	6.1	4.6	1.4	0.4	108	9.4	320	193
February	33.2	17.9	41.3	7.5	65	36	55.3	147.3	2.3	108.5	6.4	5.2	1.7	0.7	61	9.3	257	152
March	31.4	16.4	39.3	-4.2	71	36	56.1	193.5	0	92.5	6.4	4.9	1.5	0.6	83	9.0	249	133
April	27.7	11.9	35.2	-4.2	78	34	34.3	102.0	0	59.2	4.7	3.7	1.1	0.4	-	8.9	183	87
May	24.0	5.8	37.5	-6.7	74	31	13.5	91.3	0	38.8	2.2	1.9	0.4	x	-	8.8	147	57
June	21.5	2.3	30.0	-8.9	75	30	7.9	53.6	0	38.1	1.0	0.7	0.3	x	-	8.5	112	41
Annual	28.9	11.0	42.6	-15.2	62	28	304.9	706.0	134.0	213.4	39.9	31.2	9.2	3.2	44	9.5	2,692	1,474
Record (Years)	(1959-80)	(1959-80)	(1964-79)	(1934-1980)	(1934-1980)	(1934-1980)	(1934-80)	(1965-80)	(1960-73)	(1965-80)								

TSABONG (Contd.)

Month	Mean Station Level Pressure (mb)			SOIL TEMPERATURE (C°)									Mean Wind Speed (km/hr)	Wind Direction Rose (Annual) (% Frequencies)
	0800	1400	2000	0800			1400			2000				
				10cm	20cm	60cm	10cm	20cm	60cm	10cm	20cm	60cm		
July	910.1	908.3	908.6	6.5	11.2	14.2	11.4	12.0	14.1	11.8	13.9	14.0	6.2	<p>(0800+1400+2000 hrs)</p>
August	908.9	906.7	906.8	8.3	13.2	15.6	14.3	14.0	15.4	14.4	15.9	15.4	8.3	
September	906.2	904.1	904.2	13.2	18.0	19.2	19.8	19.1	19.1	20.1	20.7	19.1	9.1	
October	904.5	902.0	902.1	17.1	22.3	23.1	24.8	23.6	22.8	23.9	25.4	22.8	10.4	
November	902.9	900.1	900.2	19.9	24.5	26.1	29.0	27.0	26.0	25.7	28.5	26.1	9.3	
December	901.5	899.6	898.7	24.3	26.5	28.2	30.1	28.3	27.9	30.2	30.6	28.0	10.2	
January	901.4	899.7	898.7	22.8	27.4	29.0	30.1	28.9	28.9	30.3	30.6	28.8	9.6	
February	901.6	900.1	899.3	21.0	26.8	28.7	28.9	28.1	28.5	28.1	30.7	28.5	7.8	
March	903.8	902.7	901.7	20.2	24.8	27.1	27.0	26.1	26.6	26.4	27.9	26.8	6.9	
April	905.4	903.8	903.9	15.0	20.5	23.7	20.2	21.1	22.9	20.8	23.7	23.3	5.4	
May	907.4	905.7	906.2	9.9	14.4	19.3	15.5	16.1	18.2	15.3	18.4	18.7	4.8	
June	909.4	907.8	908.1	6.6	11.7	15.5	12.1	12.6	15.1	11.7	14.6	15.1	5.3	
Annual	905.3	903.4	903.2	15.4	20.1	22.5	21.9	21.4	22.1	21.6	23.4	22.2	7.8	
Record (Years)	(1959-1980)	(1959-1980)	(1959-1980)	(1959-1980)	(1959-1980)	(1959-1980)	(1959-1980)	(1959-1980)	(1959-1980)	(1959-1980)	(1959-1980)	(1959-1980)	(1969-78)	

MAP NO.1
Mean Annual Rainfall (mm)
and
Percentage Variability

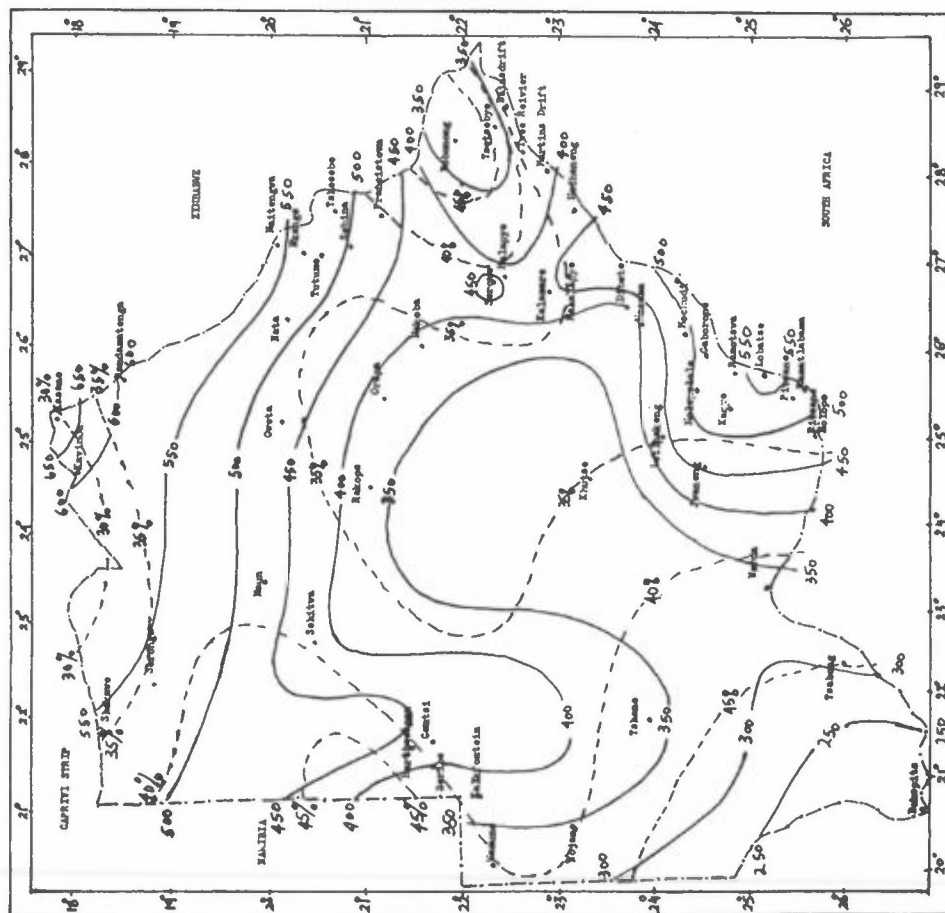

MAP NO.2
Mean Annual Rainfall (mm)

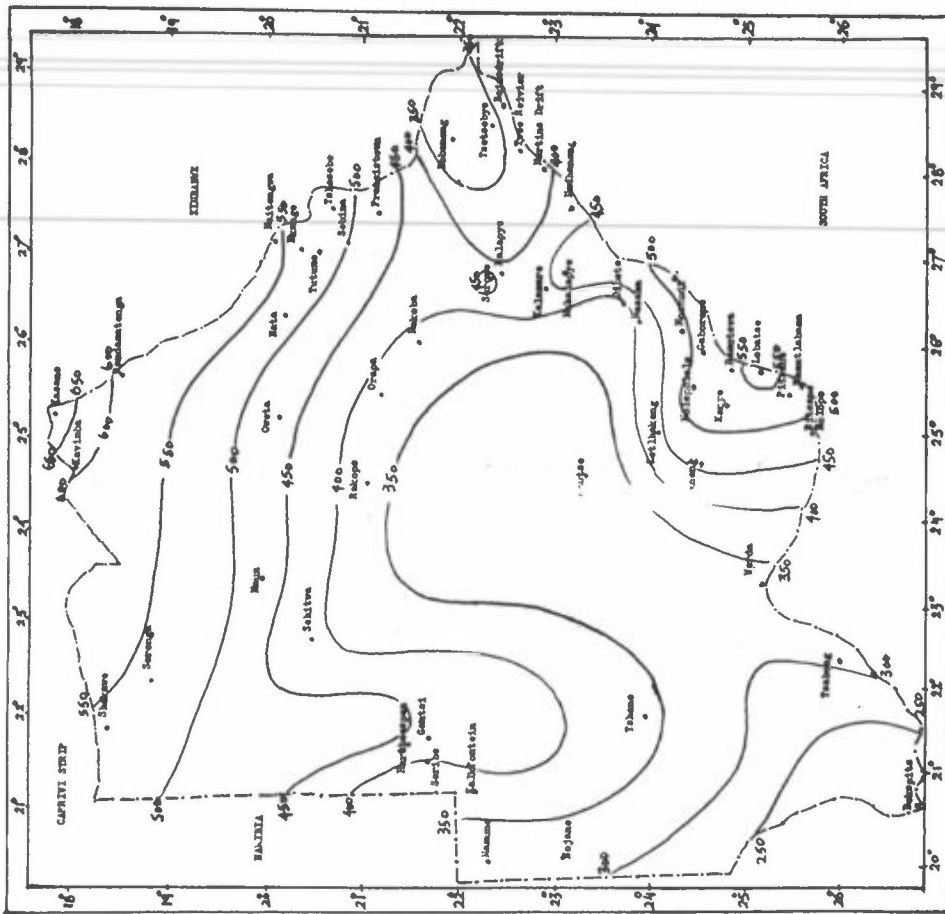

MAP NO.3
Coefficient of Variation of Mean Annual Rainfall (%)

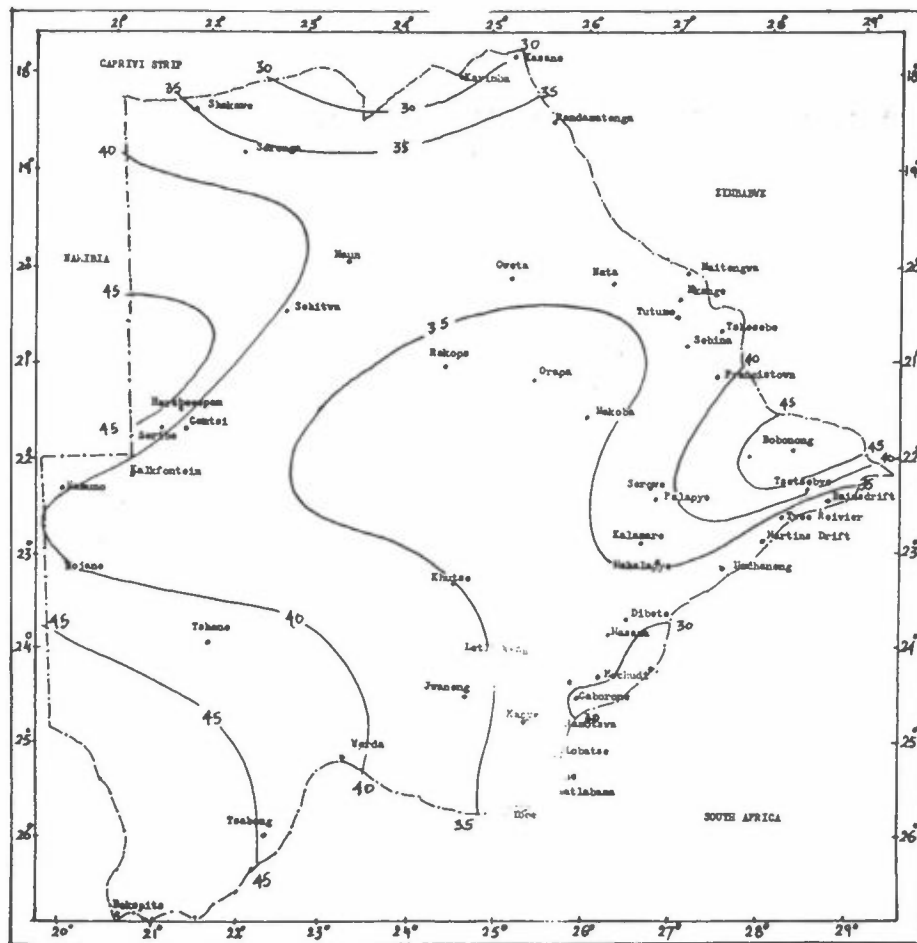

Department of Meteorological Services 1984

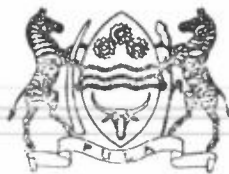

REPUBLIC OF BOTSWANA

DEPARTMENT OF METEOROLOGICAL SERVICES
MINISTRY OF WORKS AND COMMUNICATIONS

CLIMATE OF BOTSWANA
PART I : CLIMATIC CONTROLS

BY

Y.P.R. BHALOTRA

ISSUED BY THE DIRECTOR, BOTSWANA METEOROLOGICAL SERVICES, GABORONE

PRICE-P3.00

DEC. 1984

Sunshine and Solar Radiation

&

Evaporation1. Sunshine

The duration of bright sunshine is recorded at all the nine synoptic stations in Botswana, which are equipped with the Cambell-Stokes sunshine recorders. The mean monthly hours of bright sunshine recorded at the stations are shown in Table 1. Kasane was established in 1982 and as such the means for this station are based only on three years data. The lower figures, in brackets, indicate bright sunshine duration as percentage of the day-length. The day-length has been defined as the time during which the centre of the sun is above the horizon. The values of day-length used are those calculated by Andringa and Idzenga (June, 1985) according to the formula of Sayigh (1978). The day-length so defined is taken as an approximate measure of the maximum possible hours of bright sunshine though this may be an over-estimate (by 10-20 minutes for the above stations which are at an elevation of about 1000m a.s.l.), as bright sunshine occurs only when irradiance reaches values of 100 to 200 WM^2 (WMO, 1983).

Table 1Mean Monthly Hours of Bright Sunshine

<u>Station</u>	<u>July</u>	<u>Aug</u>	<u>Sept</u>	<u>Oct</u>	<u>Nov</u>	<u>Dec</u>	<u>Jan</u>	<u>Feb</u>	<u>Mar</u>	<u>Apr</u>	<u>May</u>	<u>June</u>	<u>Annual</u>
Gaborone (1962-85)	9.4 (89)	9.9 (88)	9.7 (82)	9.2 (73)	8.7 (66)	9.2 (68)	8.6 (65)	8.7 (68)	8.1 (67)	8.3 (73)	9.2 (85)	8.8 (84)	9.0 (75)
Mahalapye (1975-85)	9.1 (85)	9.2 (82)	8.6 (72)	8.7 (69)	8.0 (61)	8.3 (62)	7.9 (60)	8.0 (63)	7.9 (65)	8.5 (74)	8.9 (82)	8.6 (84)	8.5 (71)
Kasane (1982-85)	9.1 (83)	9.9 (87)	10.0 (84)	7.8 (63)	7.6 (59)	6.2 (47)	6.8 (52)	8.0 (63)	6.7 (55)	8.5 (73)	9.0 (81)	8.8 (81)	8.2 (68)
Francistown (1961-85)	9.6 (89)	9.9 (88)	9.6 (81)	8.9 (71)	8.0 (62)	7.5 (56)	8.0 (61)	8.3 (65)	8.3 (69)	8.4 (73)	9.4 (85)	9.0 (84)	8.7 (73)
Maun (1967-85)	9.8 (90)	10.2 (90)	10.0 (84)	8.8 (70)	8.1 (62)	8.3 (63)	7.8 (60)	7.5 (60)	8.3 (69)	8.9 (77)	9.7 (87)	9.6 (89)	8.9 (74)
Shakawe (1967-85)	9.0 (82)	10.0 (88)	10.1 (85)	8.4 (68)	7.2 (56)	7.5 (57)	7.1 (55)	7.6 (60)	8.1 (67)	8.9 (77)	9.3 (84)	9.4 (86)	8.6 (72)
Ghanzi (1965-85)	10.0 (93)	10.4 (92)	10.0 (84)	9.5 (76)	8.7 (67)	9.2 (69)	8.2 (62)	8.3 (65)	8.3 (69)	8.7 (76)	9.8 (89)	9.2 (86)	9.2 (77)
Tshane (1965-85)	9.8 (92)	9.9 (88)	9.7 (82)	9.8 (78)	10.0 (76)	9.6 (71)	9.1 (68)	8.5 (66)	8.9 (74)	8.5 (75)	9.7 (90)	9.1 (87)	9.4 (78)
Tsabong (1959-85)	9.0 (86)	10.1 (91)	9.9 (83)	10.4 (83)	10.5 (79)	10.6 (78)	9.8 (73)	9.8 (76)	9.0 (74)	9.3 (82)	8.8 (82)	8.8 (85)	9.7 (81)

As one would expect in these latitudes, a high percentage of the possible sunshine duration occurs over Botswana - the annual average is minimum over the north and northeast

Mahalapye (1975-85)	16.2	18.8	21.1	23.6	23.9	24.7	23.9	23.3	21.3	19.2	16.8	15.0	20.7
Francistown (1961-85)	17.4	20.1	22.8	24.0	23.8	23.3	24.1	23.8	22.2	19.5	19.0	16.1	21.3
Kasane (1982-85)	17.7	20.9	23.9	22.5	23.0	21.1	22.0	23.4	20.1	20.2	18.4	16.8	20.8
Maun (1967-85)	17.9	20.7	23.5	23.9	23.9	24.5	23.7	22.6	22.2	20.4	19.8	17.0	21.7
Shakawe (1967-85)	17.6	21.0	24.0	23.4	22.4	23.1	22.5	22.8	22.2	20.7	18.8	17.4	21.3
Ghanzi (1965-85)	17.4	20.4	23.2	24.9	24.9	26.1	24.4	23.8	22.1	19.7	18.2	15.9	21.8
Tshane (1965-85)	16.5	19.3	22.4	25.1	26.9	26.7	25.8	24.0	22.6	19.0	17.4	15.3	21.8
Tsabong (1959-85)	15.1	18.9	22.2	25.9	27.6	28.4	27.0	25.8	22.4	20.5	15.8	14.3	22.0
Sebele (1976-82)	15.0	17.3	20.2	22.6	23.7	25.5	21.4	21.8	19.4	17.8	15.8	14.5	19.6

It may be noted that the average annual values of global irradiance vary from $21 \text{ MJm}^{-2} \text{ day}^{-1}$ to $22 \text{ MJm}^{-2} \text{ day}^{-1}$ (or $5.8 \text{ KWh m}^{-2} \text{ day}^{-1}$ to $6 \text{ KWh m}^{-2} \text{ day}^{-1}$ or $500 \text{ cal cm}^{-2} \text{ day}^{-1}$ to $525 \text{ cal cm}^{-2} \text{ day}^{-1}$), being higher in the west and southwest compared to rest of the country. The values are, generally, highest in December ($23-27 \text{ MJm}^{-2} \text{ day}^{-1}$) and lowest in June ($14-17 \text{ MJm}^{-2} \text{ day}^{-1}$).

The diminishing stock of fossil fuels and the harmful environmental effects of their increasing consumption has stimulated a growing interest in the use of Solar radiation as an alternative source of energy. This has resulted in increasing demand for values of Solar radiation from agriculturists and from people engaged in house designs and those using solar energy in panels for water heaters and photovoltaic cells.

Note: Considering that 1982 to 1985 were drought years with higher than normal duration of bright sunshine hours at Gaborone, the calculated average daily values of total solar radiation for Gaborone and the actual values recorded at the Agricultural Research Station, Sebele, are nearly similar.

(of the order of 70%) and is maximum over the drier west and south-west (of the order of 80%); during the dry winter months, May and September, it ranges from 80% to over 90% and during the rainy summer months it varies from 50% to 70%, the higher values occurring in the west and southwest.

2. Solar Radiation

In Botswana there is only one station, Sebele near Gaborone, maintained by the Department of Agricultural Research where regular measurements of solar radiation are being taken for the past ten years. The Department of Meteorological Services has only recently (1985-86) established three Radiation stations at Gaborone, Maun and Ghanzi. As mentioned under para 1, the Department regularly measures bright sunshine duration at nine synoptic stations in the country. The relation between the duration of bright sunshine and the received total solar radiation (global irradiance) on a horizontal surface is given by the Angström formula:

$$R = R_0 \left(a + b \frac{N}{N_0} \right), \text{ where}$$

R = monthly averaged total solar radiation on a horizontal surface ($\text{MJm}^{-2} \text{ day}^{-1}$),

R_0 = monthly average of extra-terrestrial (on top of atmosphere) Solar radiation on a horizontal surface ($\text{MJm}^{-2} \text{ day}^{-1}$),

N = duration of bright sunshine (in hours rounded off to tenth of an hour)

N_0 = day-length (in hours rounded off to tenth of an hour)

and a and b are empirically determined constants. For Botswana, the suggested values (FAO, 1984) are $a = 0.28$ and $b = 0.49$.

The calculated average daily values of total Solar radiation at the nine synoptic stations, are given in Table 2. The actual values recorded at the Agricultural Research Station, Sebele (which are comparable to those calculated for Gaborone) are also shown in the table.

Table 2

Calculated Average Daily Total Solar Radiation
on Horizontal Surface
(in $\text{MJm}^{-2} \text{ day}^{-1}$)

<u>Station</u>	<u>July</u>	<u>Aug</u>	<u>Sept</u>	<u>Oct</u>	<u>Nov</u>	<u>Dec</u>	<u>Jan</u>	<u>Feb</u>	<u>Mar</u>	<u>Apr</u>	<u>May</u>	<u>June</u>	<u>Annual</u>
Gaborone (1962-85)	16.0	19.1	22.1	24.2	24.9	26.2	25.1	24.3	21.2	18.5	16.5	14.6	21.1

Fig.5 (a)

GABORONE (1968-73)

(0500 + 0800 + 1100 + 1400 + 1700 + 2000 L.T.)

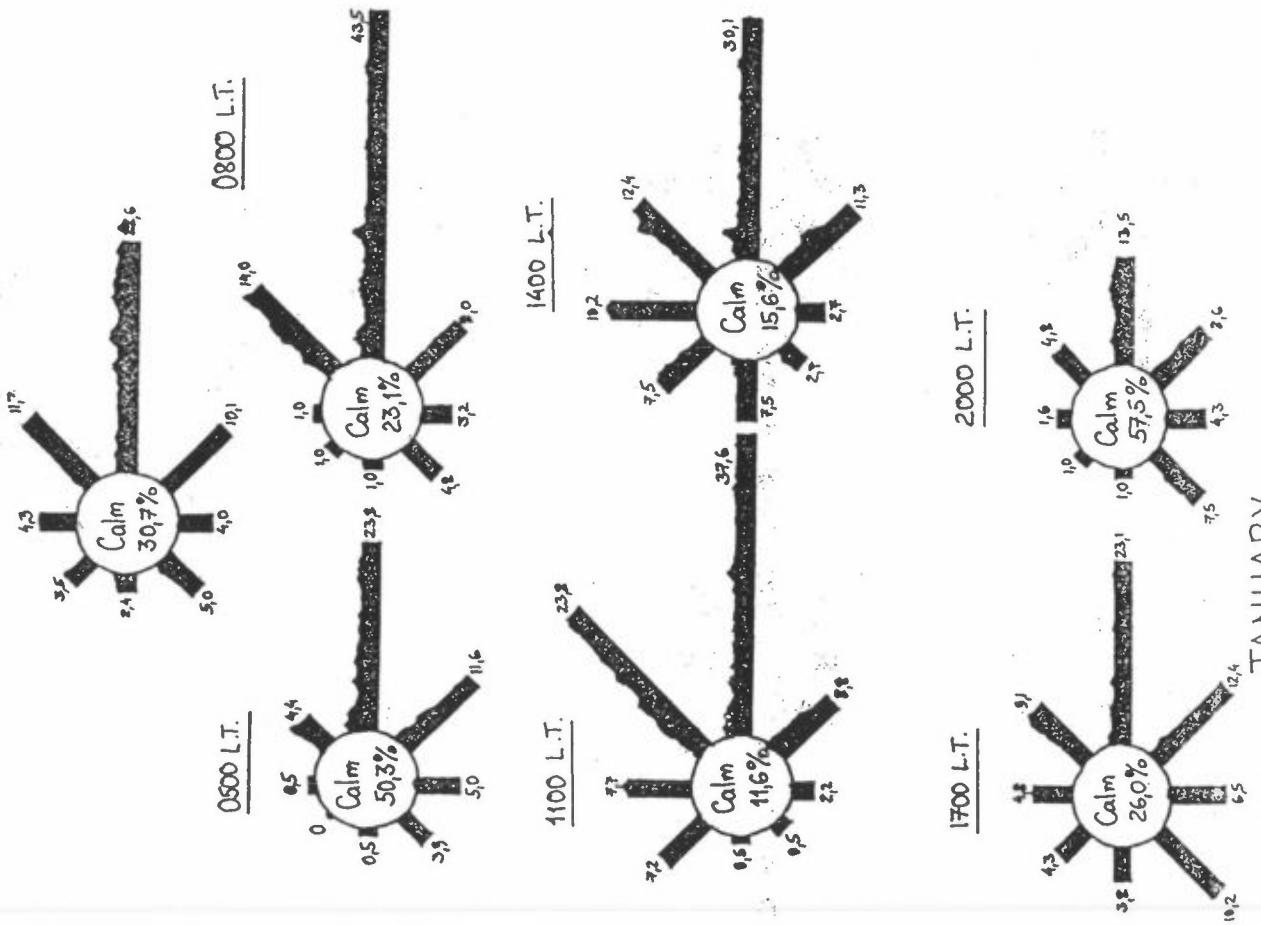

JANUARY

GABORONE (1968-73)

(0500 + 0800 + 1100 + 1400 + 1700 + 2000 L.T.)

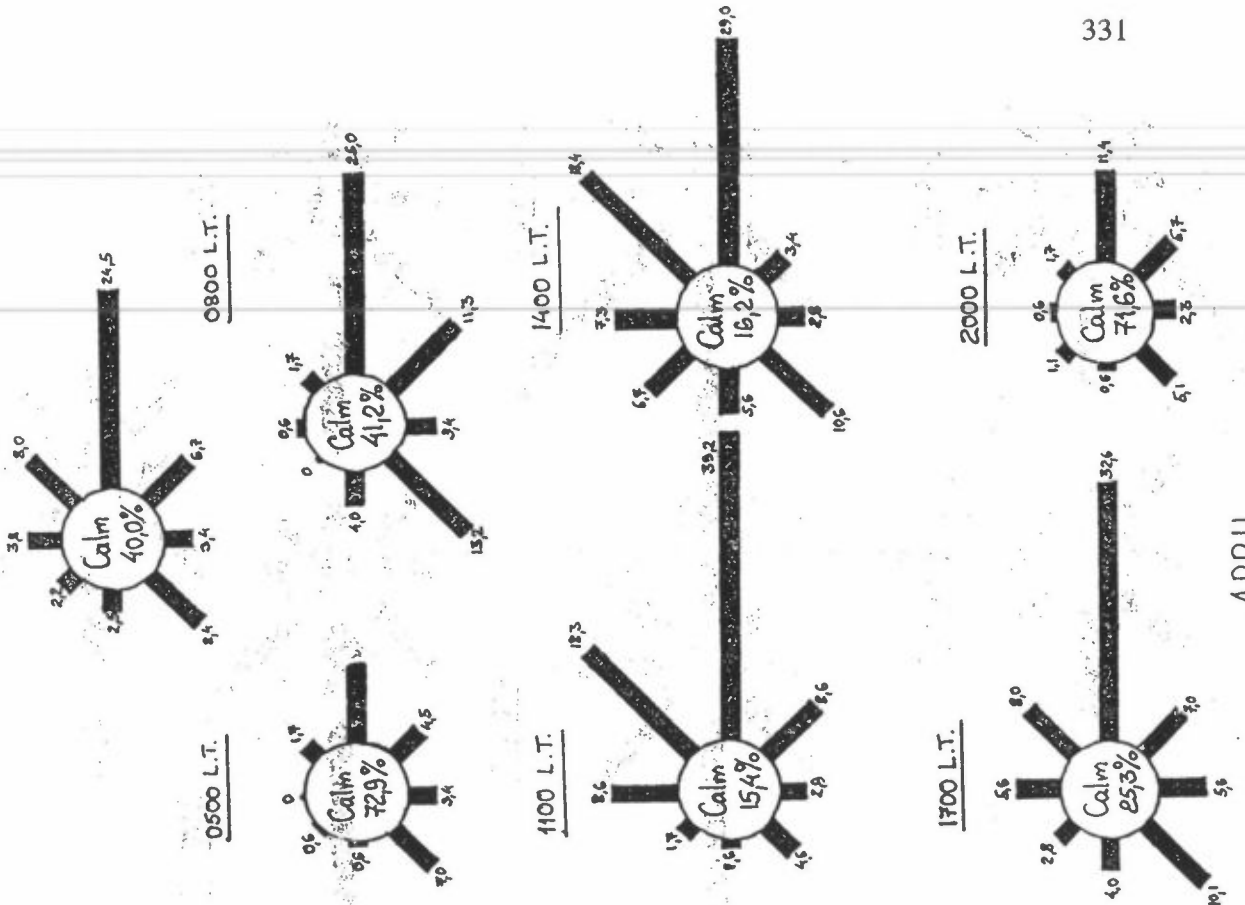

APRIL

Fig. 5 (c)

GABORONE (1968-73)

(0500 + 0800 + 1100 + 1400 + 1700 + 2000 L.T.)

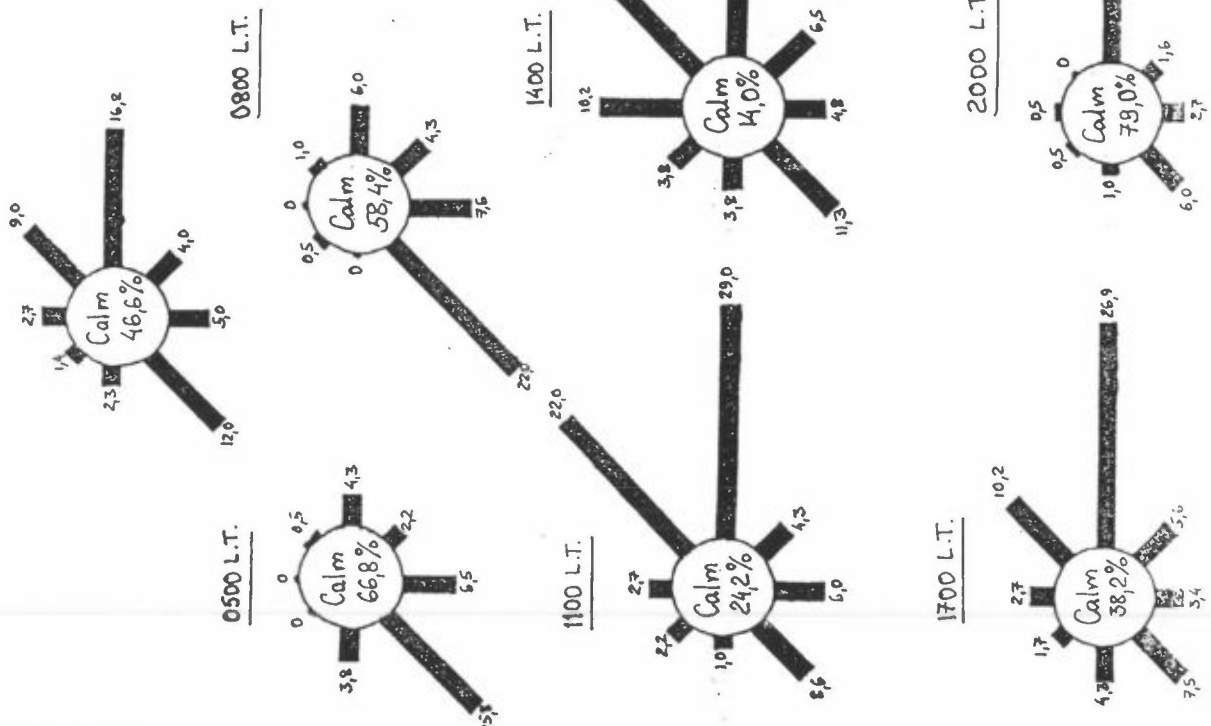

JULY

Fig. 5 (d)

GABORONE (1968-73)

(0500 + 0800 + 1100 + 1400 + 1700 + 2000 L.T.)

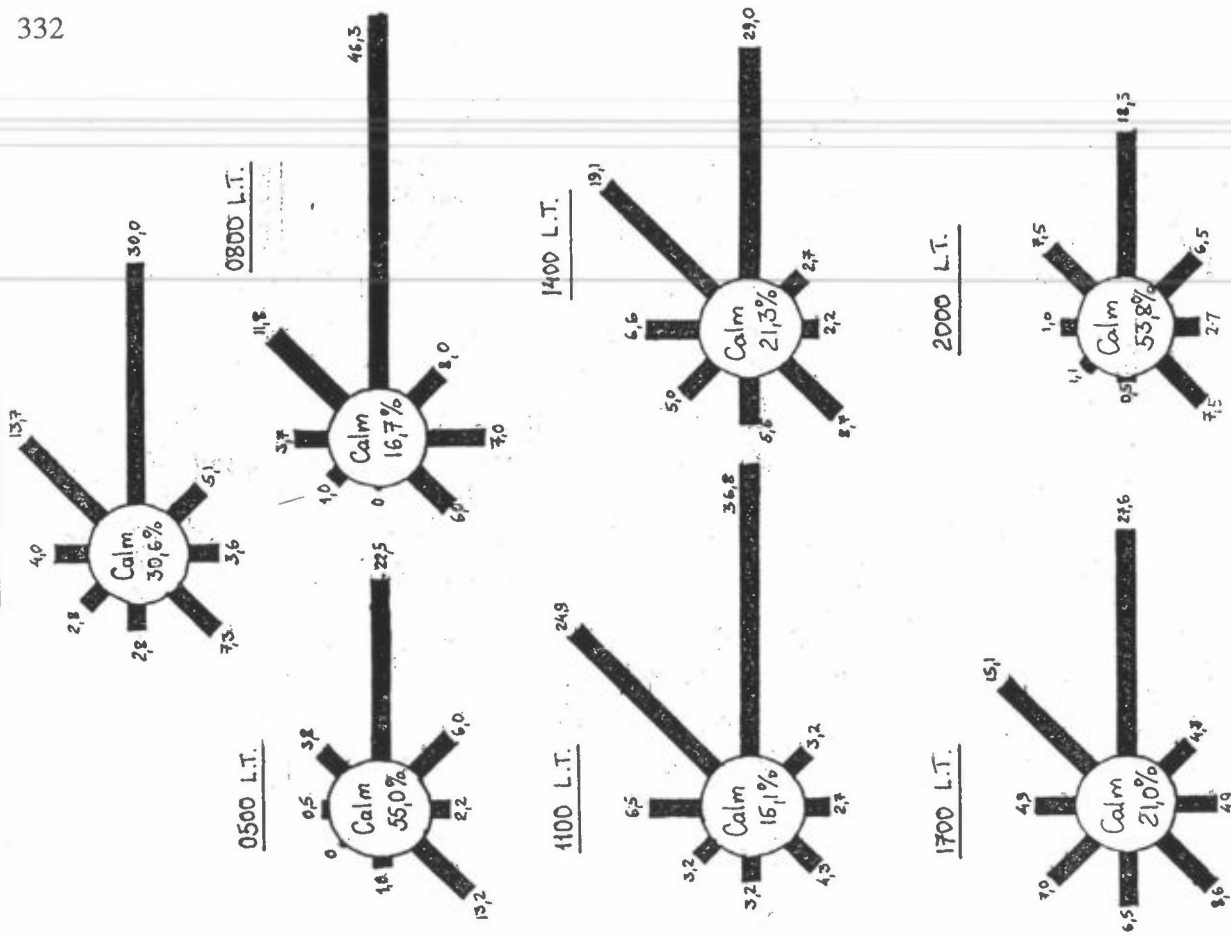

OCTOBER

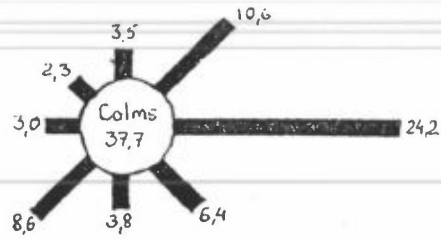

GABORONE (1968-73)

0500 + 0800 + 1100 + 1400 + 1700 + 2000 hours

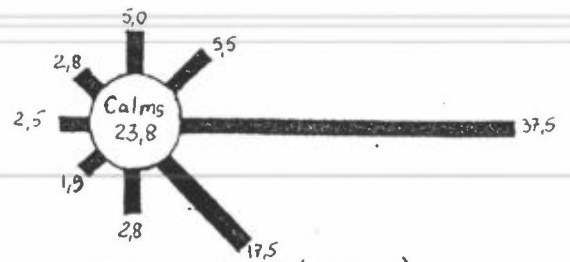

FRANCISTOWN (1969-78)

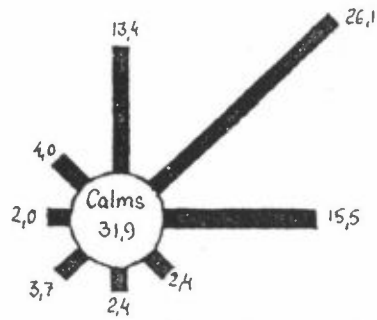

MAHALAPYE (1965-69)

0800 + 1400 + 2000 hours

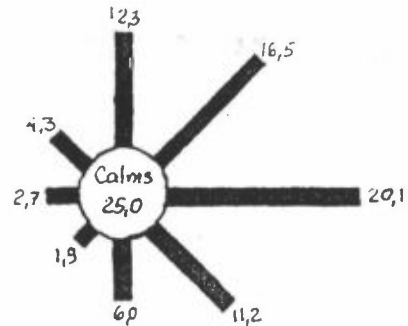

MAUN (1969-78)

0500 + 0800 + 1100 + 1400 + 1700 + 2000 hours

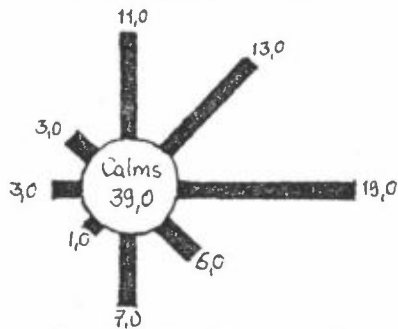

GHANZI (1965-69)

0800 + 1400 + 2000 hours

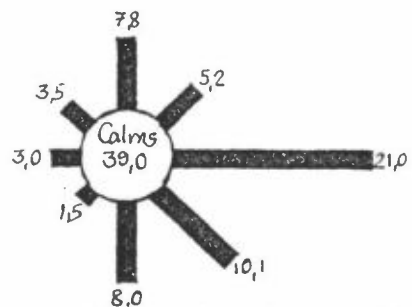

SHAKAWE (1964-69)

0800 + 1400 + 2000 hours

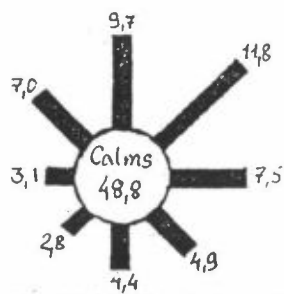

TSHANE (1979-83)

0800 + 1400 + 2000 hours

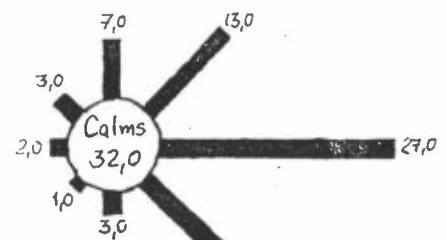

KASANE (1982-86)

0800 + 1100 + 1400 + 1700 hours

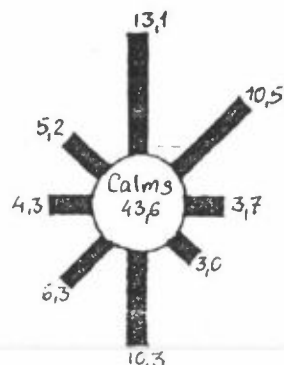

TSABONG (1969-78)

0300 + 1400 + 2000 hours

Appendix Z
Annual Report 1993
Air Pollution Control Dept. of Mines



REPUBLIC OF BOTSWANA

DEPARTMENT OF MINES

AIR POLLUTION CONTROL

Annual Report

1995

1. SUMMARY

During 1995 the Department of Mines continued with air pollution surveillance and abatement programs pursuant to the Atmospheric (Pollution) Act. The Department's air pollution monitoring stations, deployed throughout the country, are designed to measure sulphur dioxide and/or total suspended particulates.

Ambient air quality monitoring activities continued to be concentrated in the Selebi-Phikwe area where government air pollution sampling instruments, supported by a BCL Limited air pollution monitoring programme, measure the effects of emissions from the copper/nickel smelter and the BPC coal-fired power station. All eight air pollution monitoring stations in the residential areas of Selebi-Phikwe recorded annual mean sulphur dioxide concentrations within the government guideline of $80 \mu\text{g}/\text{m}^3$ as shown below:

GRB Hospital (Mines Station):	$40 \mu\text{g}/\text{m}^3$
GRB Hospital (BCL Station) :	$30 \mu\text{g}/\text{m}^3$
BCL Family Clinic :	$17 \mu\text{g}/\text{m}^3$
Botshabelo Township :	$20 \mu\text{g}/\text{m}^3$
Low Density Area :	$10 \mu\text{g}/\text{m}^3$
Township West :	$50 \mu\text{g}/\text{m}^3$
Selebi-Phikwe Sec. School :	$50 \mu\text{g}/\text{m}^3$
Orlando (Meriting) :	$50 \mu\text{g}/\text{m}^3$

The Water Utilities Corporation and the Railway Track monitoring stations, which are non-residential areas, recorded sulphur dioxide levels of $80 \mu\text{g}/\text{m}^3$ and $90 \mu\text{g}/\text{m}^3$ respectively.

At the smelter, the slag tap floor, the smelter west (a) and (b) monitoring sites recorded sulphur dioxide concentrations of 19650 $\mu\text{g}/\text{m}^3$, 1340 $\mu\text{g}/\text{m}^3$ and 1360 $\mu\text{g}/\text{m}^3$ respectively. The levels at the slag tap floor station exceed the threshold limit value of 15 000 $\mu\text{g}/\text{m}^3$ recommended by the American Conference of Governmental and Industrial Hygienists (ACGIH) for occupational environment, whereas those of the smelter west stations were within this limit.

The average sulphur dioxide concentrations of 20 $\mu\text{g}/\text{m}^3$ and 30 $\mu\text{g}/\text{m}^3$ recorded at Gaborone, 20 $\mu\text{g}/\text{m}^3$ at Lobatse, 20 $\mu\text{g}/\text{m}^3$ at Palapye and 30 $\mu\text{g}/\text{m}^3$ at Francistown were within the government air quality objectives for residential areas.

The BPC Morupule Power station sulphur dioxide emissions, as determined from source testing, averaged 1400 kg/hr during 1995. This is within the 2636 kg/hr maximum emission rate permitted by their registration certificate.

Concentrations of copper, cadmium, manganese, and lead in the natural waterways of the Motloutse and Letlhakane river system around the BCL mining area are within acceptable levels as compared to the World Health Organisation (WHO) recommended standards for drinking water.

The air pollution monitoring network was expanded to cover Mmadinare and Tonota. These new stations, equipped with state-of-the-art air pollution monitoring equipment, were commissioned in July 1995. Data collected so far is not enough to enable the Department of Mines to make any conclusion.

The Department of Mines continued with the study to address the emissions of greenhouse gases and global warming in collaboration with the Department of Meteorological Services. A report on Inventory of Sources and Sinks of Greenhouse Gases in Botswana is due to be released in early 1996. This project is part of

Botswana's response to the United Nations Framework Convention on Climate Change.

2. ADMINISTRATION

2.1. Legislation

The Atmospheric Pollution (Prevention) Act empowers the Government of Botswana, through the Department of Mines, to monitor and regulate the emissions of atmospheric contaminants from industrial processes in the declared controlled areas. Under the act, industrial processes releasing air borne contaminants are required to apply for Air Pollution Registration Certificates (APRC). The application describes the process for which the permit is sought, gives the quantity and quality of the raw materials input, and the types and quantities of pollutants to be produced by the process, and pollution reduction facilities to be used to mitigate emission problems.

On granting the APRC, the Air Pollution Control Officer specifies in the certificate, maximum permissible emission rates that each industrial process may release into the atmosphere. Each process is treated individually and given its own emission limits taking into account the nature of the process and the toxicity of the pollutant being generated. Inspectors conduct regular inspections of all industrial processes to ensure compliance with these emission or discharge standards.

In 1995 the Air Pollution Control Division of the Department of Mines conducted fourteen industrial process inspections, four stack testing work, and ten dust sampling and analysis at some quarries in the country. Most of the facilities were in compliance with the requirements of the Atmospheric Pollution (Prevention) Act except for minor operational problems which the companies were instructed to correct.

In addition to industrial process inspection the Department of Mines has introduced an environmental auditing programme. This is basically a systematic evaluation of a company and its facilities to determine whether or not environmental performance complies with the company's environmental management strategy, and whether or not the strategy is implemented effectively and the strategy is adequate to fulfill the company's environmental policy. Because of the shortage of skilled manpower environmental auditing is limited to plants that are considered as potential polluters and to those in which industrial process inspections have revealed serious pollution problems.

An environmental auditing of Soda Ash Botswana (Pty) Ltd. (SAB) was carried out by the division during the year. The objectives of the exercise were:

to undertake a comprehensive inspection of SAB plant in order to determine the company's environmental performance;

to assess material/chemical handling practices at all SAB facilities in order to determine if there were any potential danger of environmental pollution as well as identifying any pollution prevention opportunities;

to conduct a general survey of the surroundings in order to determine if there were any indicators of environmental degradation that might be attributable to SAB operations; and

to compare the company's environmental performance with its environmental policy.

It was concluded that SAB needed to improve its environmental compliance. Administrative order was issued to the company regarding the over loaded sewerage ponds which were spilling effluent onto the surrounding environment. However, the company went into liquidation shortly after this order was given. The problem will be taken up with the new company that has taken over the plant.

The BCL Limited completed the repairs of eleven compensators which were causing low level emissions of sulphur dioxide instead of discharge through the main smelter stack. This was also the result of statutory instructions that were issued to the company in the previous year.

2.2. Staff

The Air Pollution Control Division continued to experience shortage of industrial process inspectors during the year. Mr. M. Moje who joined the Division in June 1994 as Assistant Environmental Engineer went on one year secondment to Botswana Ash (Pty) Ltd with effect from November 1995. Mr. T. Tshukudu (a Chemical Engineering graduate) and Miss C.K. Lenyatso (a B.Sc. graduate with Chemistry major) joined the Division in June and August 1995 respectively. This has brought the staff of the Division up to ten, comprising of five professionals and five technical officers. Mr. A. Mukuwa, Technical Officer Instruments was transferred to Selebi-Phikwe as a result of the establishment of air quality monitoring stations at Mmadinare and Tonota.

Two Technical Officer positions remained vacant during the year. It is very difficult to acquire suitably qualified personnel from the pollution related or environmental fields at this level. It is hoped that the situation will improve for the better in the next year as some of the undergraduate chemical and environmental engineers complete their studies.

2.3. Facilities

The Department of Mines continued to operate two laboratories, one in Gaborone and the other in Selebi Phikwe. The Gaborone Environmental Laboratory is now

equipped to measure trace metal concentrations in water samples using atomic absorption Spectra photometer. An additional instrument, UV/Visible Spectrophotometer, was purchased for the laboratory in 1995, this will enable the determination of non-metal pollutants from the mining industry. Other ancillary equipment which will enable inspectors to make pollution sport checks were also procured during 1995.

A total of twenty one stations including Tonota and Mmadinare were used to monitor air pollution levels in the country. Ten of these stations were operated by the Department of Mines. Each monitoring station is equipped to measure one or both of the following air quality parameters; sulphur dioxide (SO₂) concentrations and total suspended particulate (TSP).

2.3.1. New Developments

In July 1995 two air quality monitoring stations were commissioned, one at Mmadinare and the other at Tonota. The Mmadinare station is equipped to measure sulphur dioxide, carbon monoxide, inhalable dust and meteorological parameters such as wind direction, wind speed and ambient temperature. The Tonota station is equipped with SO₂ analyser and meteorological instrument. These stations have been established to determine long-range transport of pollutants from their sources.

Unlike the old stations Mmadinare and Tonota produce real time data with up to the minute pollution concentration shown on a visual display unit of the data acquisition system. The data from each station is transferred to the base station manually in a diskette. The base station consists of a computer with appropriate software for data analysis and reporting (Figure 1).

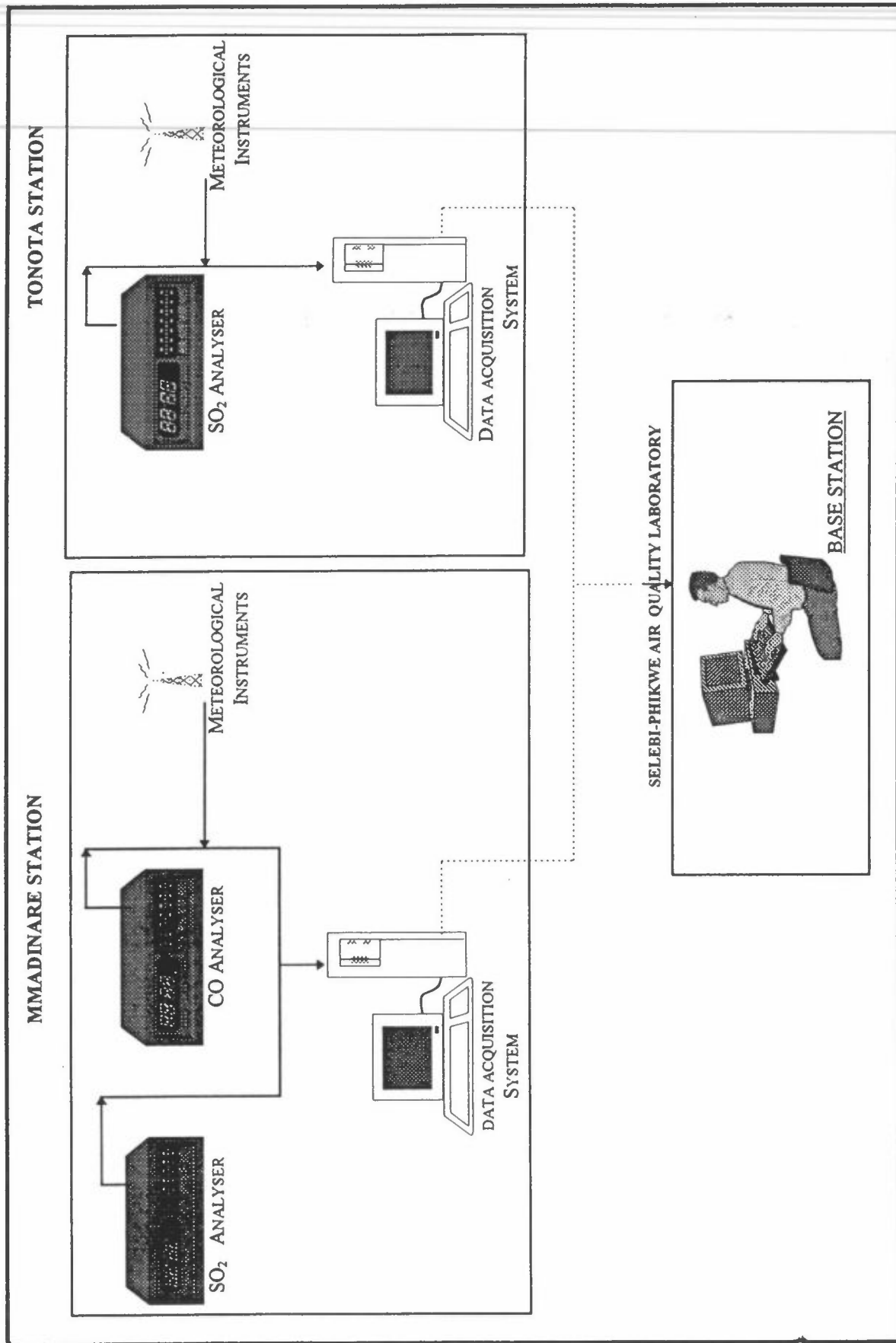

At Serowe equipment housing was erected in 1995. The delivery of the instruments and the commissioning of the station is expected in March, 1996.

Pollutants monitored will be SO₂, NO_x, and CO. Wind speed and direction, and ambient temperature will also be measured at the site.

3. GABORONE CONTROLLED AREA

3.1. Sources of Air Pollution

Sources of air pollution in Gaborone are Botswana Breweries, Kgalagadi Breweries, Kgalagadi Soap Industries, Textile Industries and small scale chemical and other industries. The larger sources burn coal to produce steam and/or hot water, thus generating mainly sulphur dioxide and particulate matter, while small scale industries produce a variety of pollutants. Construction of a pipes factory in Phakalane industrial estate started in 1992 and the potential emissions from this source would be styrene, an aromatic hydrocarbon.

The non-industrial sources include government institutions where coal and/or gas are used as energy sources, traffic and fugitive dust emissions from untared roads. Open burning of refuse creates a visible air pollution problem especially in winter when temperature inversions are prominent.

3.2. Ambient Air Quality in Gaborone

The 1995 sulphur dioxide average concentrations of 20 µg/m³ and 30 µg/m³ recorded at the Gaborone main mall and the Old Naledi respectively, are well within the government guideline of 80 µg/m³. However, other pollutants which might be of more significance in terms of public health and welfare are not yet monitored by the

department. Plans are underway to start measuring atmospheric concentrations of CO, HCs, NO_x, O₃ and VOCs in the city and other locations where the presence of these air contaminants is suspected.

The “Mines Lab” station located in the main mall will be upgraded and split into two stations. One of these stations (Gaborone Central or G1) will be located within the premises of the Civic Centre and the other (Gaborone West or G2) at the Fire Department in Gaborone West. The Old Naledi Station (or G2) will be upgraded to use continuous analysers for SO₂ and NO_x. These new developments will enable the monitoring of non-industrial air pollution such as traffic exhaust emissions.

The ambient air quality in Gaborone was found to be good with respect to SO₂ during the year.

3.3. Wind Patterns

Winds in Gaborone prevail from the north east through east directions; thus blowing pollution to the west and south-westerly direction.

3.4. Guidelines for Future Developments in Gaborone

For years, the locations of the two industrial sites in the west and south western regions of Gaborone have been quite suitably sited. In these regard, emissions were being carried away from most of the residential areas by the prevailing winds.

With the recent developments in the Gaborone West, air pollution discharges from the industrial sites may be carried by the prevailing winds to these residential areas. Any new industries locating in the existing industrial sites should be equipped with

appropriate abatement facilities if the process involves a discharge of potential air contaminants.

4. SELEBI-PHIKWE CONTROLLED AREA

4.1. Sources of Air Pollution

The BCL Limited copper/nickel smelter and the Botswana Power Corporation power station are the major sources of air pollution in Selebi-Phikwe. Emission data from the sources is based on estimates derived from process material balances and equipment design specifications since no source emission testing data has been carried out.

Smelter waste gases from the furnaces and the converters are carried by ducts to the main smelter stack where they are discharged at high elevation to ensure dispersion and dilution before reaching ground level. In 1994 eleven compensators were found to be leaking and therefore contributing to high concentrations of SO₂ in the smelter and the surrounding areas. The BCL Limited was issued with an administrative order to take correction action. The company was required to submit to, the Air Pollution Control Officer, a plan of action and thereafter submit progress report every three months until the project was complete. They complied with all the instructions and the work was completed in June 1995.

4.2. Meteorological Observations

The 1995 meteorological observations by BCL Limited indicate that the winds prevailed from the north-east 39% of the time. The smelter stack plume characteristics show predominantly coning in the early morning and late afternoon. The looping plume was observed more than 60 percent of the time in the early mornings from September through December in 1995.

4.3. Ambient Air Quality in Residential Areas

The monthly average concentrations of sulphur dioxide in residential areas of Selebi-Phikwe for 1995 are shown in table 5 and figure 2. All the pollution monitoring stations recorded monthly averages within the government guideline of $160 \mu\text{g}/\text{m}^3$ in July 1995. The 1995 ambient sulphur dioxide concentrations in the residential areas of Selebi-Phikwe are given below:-

GRB Hospital (Mines Station):	$40 \mu\text{g}/\text{m}^3$
GRB Hospital (BCL Station) :	$30 \mu\text{g}/\text{m}^3$
BCL Family Clinic	: $40 \mu\text{g}/\text{m}^3$
Botshabelo Township	: $17 \mu\text{g}/\text{m}^3$
Low Density Area	: $10 \mu\text{g}/\text{m}^3$
Township West	: $40 \mu\text{g}/\text{m}^3$
Selebi-Phikwe Sec. School	: $50 \mu\text{g}/\text{m}^3$
Orlando (Meriting)	: $50 \mu\text{g}/\text{m}^3$

These levels are well below the government guideline of $80 \mu\text{g}/\text{m}^3$ for sulphur dioxide. The yearly average sulphur dioxide concentration in the residential areas during the monitoring period from 1979 to 1995 are shown in table 6.

4.4. Other Areas

The monthly average sulphur dioxide concentration for 1995 in non-residential areas are also given in table 5. Values in excess of thousands of micrograms per cubic metre of air are not uncommon in the vicinity of the smelter area. This is due to low level emissions from the furnaces, converters, matte and/or slag tap holes that ducting through to the smelter stack.

Figure 2
Freq. distribution of SO2 in S/Phikwe

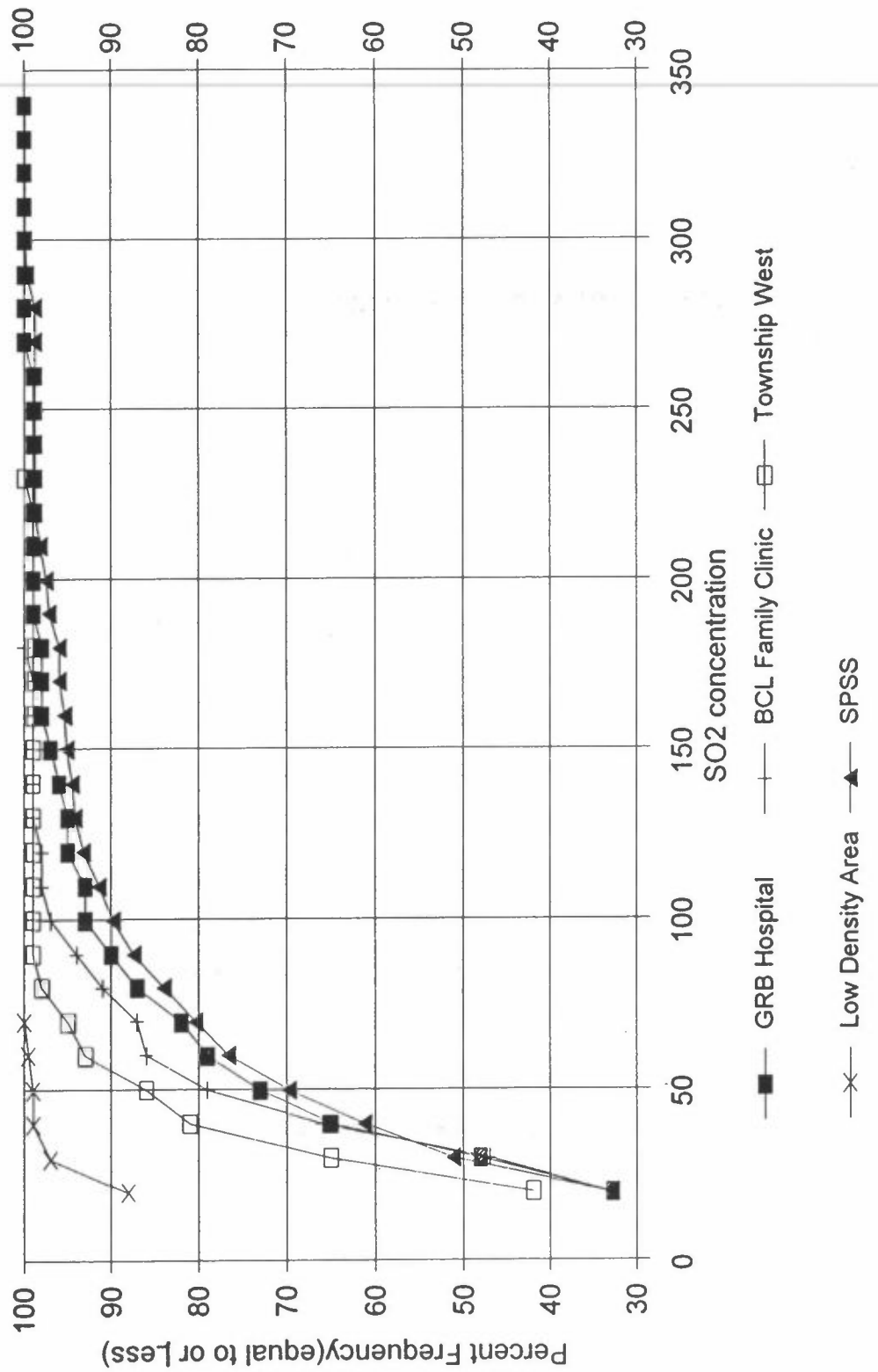

4.5. Effluent Quality

Emissions of waste gases into the atmosphere from mining and smelting operations constitute only part of the problem that may result in adverse effects on the environment. Water pollution through effluent discharges could be a formidable problem if appropriate precautionary measures are not undertaken. At BCL, like all other mines, all process water is recycled or reused. This reduces fresh water requirements and reagent costs. However, at Selebi-Phikwe seepage of effluent through the soil from tailings impoundment and inadvertent discharge could pose a potential water pollution problem along the Motloutse river. Appropriate monitoring of the whole environment is essential for the protection of public health and welfare.

In addition to the air quality monitoring programme BCL Limited measures pollution levels every week along the Motloutse river up to Tobane village. The results are reported to the Department of Mines on a monthly basis. These results have indicated that pollution levels for every metal, total dissolved solids and pH were within the World Health Organisation guidelines for seasonal streams.

4.6. Guidelines for future developments in Selebi-Phikwe

Future developments in Selebi-Phikwe should be located in areas which are least affected by air pollution. The areas affected by the emissions from the smelter/power station complex are dependent upon the prevailing meteorological conditions. Past and present meteorological records show that most of the time the wind direction is such that airborne flue gases from the smelter/power station complex are carried towards the western side of the Selebi-Phikwe township.

It is recommended that developments in the western township area should generally be discouraged. Developments should proceed in the south eastern section of the

town. This is especially important for housing developments. The western township areas of Selebi-Phikwe would be best utilised for industrial development where people would be present for only part of the day.

5. LOBATSE CONTROLLED AREA

5.1. Sources of Air Pollution

The main sources of industrial air pollution in Lobatse are the Botswana Meat Commission's coal-fired boilers, and standby diesel generators, the Lobatse Clay Works and the Lobatse Tannery.

Government institutions, traffic and open burning of refuse constitute the non-industrial sources of air pollution in Lobatse.

5.2. Air Quality in Lobatse

The monthly average concentrations of sulphur dioxide for 1995 are shown in table 6. All the concentrations recorded are well within the monthly government guideline of $160 \mu\text{g}/\text{m}^3$.

The 1995 sulphur dioxide average concentration of $20 \mu\text{g}/\text{m}^3$ recorded at the Lobatse bus terminal is well within the government guideline of $80 \mu\text{g}/\text{m}^3$.

The ambient air quality in Lobatse is judged to have been good during the year with regard to sulphur dioxide.

5.3. Guidelines for Future Development

Future developments in Lobatse are expected to take place to the north easterly direction from the existing developed area where relatively flat land is available. Potential air polluting industries are therefore discouraged from being located in this north east sector as this will most likely result in air pollution emissions being transported directly towards residential areas by the prevailing winds.

6. OTHER CONTROLLED AREAS

6.1. Francistown and Tatitown

Industrial sources of air pollution in Francistown are the sorghum beer brewery operated by the Botswana Breweries (Pty) Ltd, the Botswana Meat Commission and other small scale industries. Government institution, traffic and open burning constitute the non-industrial sources of air pollution.

The monthly and annual average concentrations of sulphur dioxide for 1995 are shown in table 8. All the concentrations recorded are well within the government guidelines. Thus, the air quality in Francistown was found to be acceptable with regard to sulphur dioxide during 1995.

6.2. Morupule and Palapye

The major source of air pollution at Morupule/Palapye area is the Botswana Power Corporation power plant near the Morupule colliery. Average sulphur dioxide concentration of $20 \mu\text{g}/\text{m}^3$ recorded at the Palapye government hospital was well within the government guideline of $80 \mu\text{g}/\text{m}^3$ for that air quality parameter.

6.3. Sua Pan

The major source of air pollution in this region is the Soda Ash plant which came into operation in 1991. The main air contaminants are sulphur dioxide, hydrogen sulphide and dust. Annual average sulphur dioxide concentrations were within the government objectives in 1995.

6.4. Mmadinare

Mmadinare is about 15 km West northwest of the BCL Limited nickel/copper smelter. With the wind blowing in that direction significant concentration of sulphur dioxide could perhaps be detected at this village.

A new air pollution monitoring station was commissioned at Mmadinare in July 1995. The station is equipped to measure SO₂, CO, temperature, wind speed and direction, and inhalable dust. There are no conclusions that can be drawn from the data since the station has only been operational for a short time.

6.5. Tonota

A sulphur dioxide monitoring station equipped also to collect meteorological data was commissioned in 1995. This station will determine long-range transport of SO₂ in Botswana and assist in dispersion model development and validation. Although it is too early to make any conclusive statements there are already some indications that pollution could travel long distances from their sources.

6.6. Other Areas

Sources of air pollution elsewhere in Botswana wood burning (for cooking and heating) and wind blown dust. The air quality in these areas is considered to have been within the acceptable levels in 1995.

7. FUTURE MONITORING PROGRAMME

The air pollution monitoring network is continuously being reviewed and improved. Current environmental understanding suggests that other pollutants that are not monitored might be of significant health implications. A compilation of inventory of combustion related stationary sources of air pollution was started during 1995. Data collected through this exercise will be useful in many ways including the development of air pollution dispersion models and determination of public exposure levels.

In 1995 funds were approved under the national development plan seven (NDP7) for the upgrading of air pollution monitoring stations at Gaborone Central and Naledi. All of these stations will be equipped with state-of-the-art technology to measure sulphur dioxide, carbon monoxide, volatile organic compounds, ozone, nitrogen oxides and meteorological parameters such as wind direction and ambient temperature.

Improvement of the air quality monitoring network throughout the country will continue covering major settlement areas. Procurement of field and laboratory equipment is an ongoing process under the NDP7 programme.

TABLE 1

GABORONE SULPHUR DIOXIDE DATA 1995

ug/m³ SO₂ Determined by the hydrogen
Peroxide Absorption Method

MONTH	CRETERIA	GRB MONITORING STATIONS	
		Mines lab	Naledi
January	24hr.max	20	20
	mean	20	20
February	24hr.max	80	70
	mean	30	20
March	24hr.max	20	20
	mean	20	20
April	24hr.max	20	20
	mean	20	50
May	24hr.max	100	70
	mean	40	20
June	24hr.max	60	30
	mean	20	20
July	24hr.max	50	20
	mean	20	20
August	24hr.max	20	30
	mean	20	20
September	24hr.max	80	60
	mean	30	20
October	24hr.max	40	40
	mean	30	20
November	24hr.max	100	30
	mean	70	20
December	24hr.max	30	20
	mean	20	20
1995			
Mean		28	23

TABLE 2

SELEBI PHIKWE AIR QUALITY MONITORING STATION

	APPROXIMATE LOCATION RELATIVE SMELTER STACK	CO CONTINUOUS ANALYSER	SO2 CONTINUOUS ANALYSER	SO2 ABSORPTION SAMPLER	SO2 CANDLE	TSP HI - VOL / PM10
BCL MONITORING STATION						
1.Slag tap	0.2kmWSW			X		
2.Water Utilities	1.1kmWNW			X		X
3.Botshabelo	3.8kmSSE			X		
4.Smelter East	0.5kmESE			X		
5.High Density	3.4kmSW			X		
6.Low Density	4.7kmSSW			X		
7.Railway Station	4.8kmWSW			X		
8.Slag Tap Floor	beside fumace			X		X
GRB MONITORING STATION						
1.Phikwe East	1.6kmENE				X	
2.B.P.C.	0.6kmNW				X	
3.TOWNSHIP WEST	3.7kmSSW				X	
4.BDF Camp	2.8kmNNW					
5.Hospital	4.2kmSW					
6.Railway	3.7kmW			X	X	
7.Serule Road	9.0kmWSW			X	X	
8.Railway Station	4.8kmWSW			X	X	
9.Township West	5.2kmSW			X	X	
10.S/Phikwe Sec School	4.2kmSW			X	X	X
11.Mmadinare		X	X			X
12.Tonota		X	X			

TABLE 3

SELIBI PHIKWE WIND DATA 1995

MONTH	WIND DIRECTION (percent frequency)															
	N to S	NNE to SSW	NE to SW	ENE to WSW	E to W	ESE to WNW	SE to NW	SSE to NNW	S to N	SSW to NNE	SW to NE	WSW to ENE	W to E	WNW to SE	NW to SE	NNW to SSE
January	0	0	0	0	7.5	0	0	0	11.3	1.9	39.6	0	22.6	7.5	0	0
February	0	0	0	0	7.5	0	0	0	5	0	52.5	0	22.5	7.5	0	0
March	0	0	0	0	4.2	0	0	0	45.8	0	6.2	0	29.2	12.5	0	0
April																
May	0	0	0	0	4.6	0	0	0	9.2	0	61.5	0	12.3	6.2		0
June																
July																
August																
September	0	0	0	0	2	0	2	0	54	0	15	0	12	8	0	0
October	0	0	0	0	11.6	0	8.7	0	13	0	44.9	0	8.7	0	1.4	0
November	0	0	0	0	11.6	0	8.7	0	9.7	3.2	51.6	0	9.7	12.9	0	0
December																
1995 Mean	0	0	0	0	7	0	3	0	21	1	39	0	17	8	0	0

TABLE 4
BCL SMELTER STACK CHARACTERISTICS - 1995

TIME OF DAY	MONTH	% FREQUENCY OF PLUME TYPE				
		Lofting	Fanning	Conning	Looping	Fumigating
07h00	January	0	0	74	19	6
	February	3	0	54	43	0
	March	0	0	93	6	0
	April	0	6	94	0	0
	May	-	-	-	-	-
	June	-	-	-	-	-
	July	-	-	-	-	-
	August	-	-	-	-	-
	September	0	10	20	67	3
	October	0	36	3	61	0
	November	0	0	7	70	23
	December	3	0	7	83	7
12h00	January	23	0	61	0	16
	February	4	0	28	68	0
	March	0	0	83	17	0
	April	0	0	89	11	0
	May	-	-	-	-	-
	June	-	-	-	-	-
	July	-	-	-	-	-
	August	-	-	-	-	-
	September	0	10	57	33	0
	October	3	23	3	45	26
	November	0	0	7	70	23
	December	0	7	7	65	21
18h00	January	0	0	90	10	0
	February	4	0	75	21	0
	March	0	0	100	0	0
	April	0	0	100	0	0
	May	0	0	100	0	0
	June	-	-	-	-	-
	July	-	-	-	-	-
	August	-	-	-	-	-
	September	0	20	70	10	0
	October	0	45	0	52	3
	November	0	23	0	70	7
	December	0	24	0	76	0
07h00 Mean		0	15	10	66	9
12h00 Mean		2	0	57	38	3
18h00 Mean		7	1	22	49	16
07h00 Hot Mos		0	0	0	0	0
12h00 Hot Mos		7	2	45	38	9
18h00 Hot Mos		0	29	23	44	3
07h00 Cold Mos		1	6	66	27	0

June July and August = BCL plant shutdown

TABLE 5

SELIBE PHIKWE SULPHUR DIOXIDE DATA 1995

ug/m3 SO2 Determination by the hydrogen peroxide Absorption method

MONTH	CRITERIA	BCL MONITORING STATIONS				
		SMELTER WEST (a)	SMELTER WEST (b)	WATER UTILITIES	FAMILY CLINIC	RAILWAY STATION
January	24hr. max mean	3213	2556	216	101	138
February	24hr. max mean	1687	1565	85	37	60
	24hr. max mean	3617	4165	201	66	167
March	24hr. max mean	1584	1629	82	31	57
	24hr. max mean	3488	3693	144	98	96
April	24hr. max mean	1809	1855	93	40	45
	24hr. max mean	-	-	-	-	-
May	24hr. max mean	2762	2994	154	48	123
	24hr. max mean	1508	1496	99	19	55
June	24hr. max mean	-	-	-	-	-
July	24hr. max mean	-	-	-	-	-
August	24hr. max mean	-	-	-	-	-
September	24hr. max mean	2664	-	252	92	101
	24hr. max mean	1439	-	77	36	36
October	24hr. max mean	3366	-	161	113	83
	24hr. max mean	1273	-	53	50	34
November	24hr. max mean	2256	-	330	174	139
	24hr. max mean	1168	-	70	31	36
December	24hr. max mean	1806	1730	241	161	108
	24hr. max mean	219	254	61	44	48
ANNUAL Max		3620	4170	330	170	170
ANNUAL Mean		1340	1360	80	40	50

June, July and August = No Data. BCL Shut-Down.

TABLE 5 (Continued)

SELEBIPHIKWE SULPHUR DIOXIDE DATA 1995

ug /m3 SO2 Determined by the hydrogen peroxide Absorption method

MONTH	CRETERIA	BCL MONITORING STATIONS			GRB MONITORING STATIONS		
		SlagTap Floor	GRB Hospital	Low Density	GRB Hospital	Township West	Sec School
January	24 hr.max	44021	55	32	110	80	130
	Mean	25501	27	10	40	30	50
February	24 hr.max	55600	62	51	80	90	100
	Mean	27057	22	11	30	20	30
March	24 hr.max	85565	76	24	100	50	110
	Mean	28030	27	6	30	20	40
April	24 hr.max	-	-	-	100	80	280
	Mean	-	-	-	5	20	50
May	24 hr.max	-	58	28	40	110	100
	Mean	-	20	-	20	40	30
June	24 hr.max	-	-	-	50	50	40
	Mean	-	-	-	30	30	20
July	24 hr.max	-	-	-	340	40	290
	Mean	-	-	-	40	30	50
August	24 hr.max	-	-	-	90	50	190
	Mean	-	-	-	50	30	50
September	24 hr.max	20992	167	26	180	100	290
	Mean	13779	31	10	70	40	90
October	24 hr.max	56643	88	67	170	90	210
	Mean	14878	37	11	70	50	60
November	24 hr.max	15662	97	28	180	140	170
	Mean	8646	30	8	60	60	60
December	24 hr.max	-	81	21	-	-	-
	Mean	-	32	7	-	-	-
ANNUAL	Max	85570	170	70	340	140	290
	Mean	19650	30	10	40	30	50

June, July and August = No data BCL shutdown

TABLE 6

SELIBE PHIKWE SULPHUR DIOXIDE DATA 1979-1995

ug/m3 SO2 Determined by Hydrogen Peroxide Absorption Method

YEAR	CRETERIA	BCL MONITORING STATIONS							
		Smelter		Industrial		Residential			
		1 Smelter West	2 Slag Tap Floor	3 Water utilities	4 Railway Station	5 Botshabelo	6 Nata	7 High Density	8 Low Density
1979	24 hr.max	4900	42100	2560	2030	700	1670	990	960
	mean	1280	7430	240	150	60	140	80	100
1980	24 hr.max	37750	360650	1980	850	610	820	670	480
	mean	4130	42650	200	130	60	110	110	70
1981	24 hr.max	127550	2415550	1890	870	1100	1040	500	1800
	mean	5410	75210	100	130	50	80	60	100
1982	24 hr.max	7770	930860	1720	1200	630	1120	850	1320
	mean	1000	68100	250	200	60	140	90	120
1983	24 hr.max	6010	68410	890	2350	940	1110	1110	760
	mean	1170	11870	200	240	90	140	90	130
1984	24 hr.max	4850	100090	1100	800	810	840	720	180
	mean	840	14670	170	150	50	120	140	50
1985	24 hr.max	45270	77590	1760	1200	430	1150	1980	620
	mean	1480	10230	350	200	80	120	90	100
1986	24 hr.max	2120	30480	920	430	470	-	870	270
	mean	690	6530	170	110	110	-	240	60
1987	24 hr.max	2540	78390	390	740	325	-	160	310
	mean	640	18880	70	80	50	-	100	30
1988	24 hr.max	3200	145070	480	260	220	-	190	190
	mean	610	26010	80	70	30	-	20	20
1989	24 hr.max	4430	453230	310	400	180	-	30	180
	mean	1260	59160	90	60	20	-	-	20
1990	24 hr.max	10140	822890	440	500	210	-	-	210
	mean	1980	86440	110	80	20	-	-	30
1991	24 hr.max	67680	124760	750	-	170	-	-	230
	mean	1770	27680	120	-	20	-	-	20
1992	24 hr.max	-	80320	1020	570	-	-	-	140
	mean	-	28660	100	80	-	-	-	20
1993	24 hr.max	5359	90209	867	399	-	-	-	133
	mean	1870	34370	110	70	-	-	-	10
1994	24 hr.max	6282	65088	673	260	-	-	-	92
	mean	1780	27070	100	50	-	-	-	10
1995	24 hr.max	3620	85570	330	170	-	-	-	-
	mean	1340	19650	80	50	-	-	-	-

TABLE 6 (Continued)

SELIBE PHIKWE SULPHUR DIOXIDE DATA 1979-1995

ug/m3 SO2 Determined by Hydrogen Peroxide Absorption Method

YEAR	CRITERIA	MINES GRB MONITORING STATIONS				
		9 GRB Hospital	10 Railway Track	11 Township West	12 S/phikwe Sec Sch	13 Meriting (Orlando)
1979	24 hr.max	350	530	650		-
	mean	130	190	180		-
1980	24 hr.max	100	3080	580		-
	mean	190	430	70		-
1981	24 hr.max	600	990	460	850	-
	mean	110	140	50	80	-
1982	24 hr.max	970	1060	880	970	-
	mean	100	240	80	130	-
1983	24 hr.max	890	2230	850	1280	-
	mean	150	460	150	230	-
1984	24 hr.max	380	11020	700	320	-
	mean	80	210	70	70	-
1985	24 hr.max	1110	1370	440	510	-
	mean	100	180	30	50	-
1986	24 hr.max	920	1740	450	65530	-
	mean	200	250	50	90	-
1987	24 hr.maax	1370	1900	300	280	-
	mean	200	190	50	50	-
1988	24 hr.max	990	1160	370	370	-
	mean	220	190	50	50	-
1989	24 hr.max	1390	-	1210	6480	-
	mean	280	-	90	90	-
1990	24 hr.max	1410	-	490	730	-
	mean	180	-	70	100	-
1991	24 hr.max	510	-	510	420	-
	mean	70	-	60	90	-
1992	24 hr.max	120	-	100	190	-
	mean	50	-	30	40	-
1993	24 hr.max	193	306	202	376	-
	mean	40	60	50	50	-
1994	24 hr.max	185	486	237	301	206
	mean	40	110	40	40	40
1995	24 hr.max	340		140	290	
	mean	40		30	50	

TABLE 7

BCL SMELTER PRODUCTION RATE DATA, 1980 - 1995

MONTH	TOTAL CONCENTRATE DRIED (TONNES)															
	1980	1981	1982	1983	1984	1985	1986	1987	1988	1989	1990	1991	1992	1993	1994	1995
January	51172	60450	62326	70385	65634	69267	6969148	50010	71883	61252	67546	71496	68285	64769	62265	60503
February	47119	63077	57942	67770	66600	69797	65745	56110	69128	64877	66877	58369	66765	65051	61477	59028
March	17595	65624	63005	68462	73821	76853	69999	60954	75680	72498	70233	68841	69562	56782	68097	66178
April	0	63887	68551	68029	56133	61938	68145	55014	67036	71006	52284	64904	43292	66654	59762	62928
May	24401	68232	63015	67870	71422	77281	77281	25696	72252	72266	73675	64351	69380	63109	61957	30505
June	69678	57350	56537	65807	58321	65363	69651	6615	64470	51778	70738	63734	6670	72762	53398	-
July	60695	63521	53728	70684	69150	75448	65811	67619	64087	52111	71710	67607	61952	67165	60826	29870
August	60065	12510	58495	68691	61975	90844	65375	68323	63709	69221	67336	74241	70274	74322	64649	71239
September	64533	59903	67007	67007	67566	70834	68251	65031	59888	64632	63220	68882	64845	75855	50291	72845
October	63986	57805	70124	61969	70887	72759	68232	73643	70526	66101	61660	73019	67258	69837	64573	70823
November	57723	54321	61285	69286	50042	68270	50326	60343	57342	60187	64010	66698	66108	53925	58173	70999
December	65863	64659	61090	68347	74180	72985	46102	74263	71942	62307	67796	67376	62748	59363	61348	71527
Annual Total	582830	691339	743105	814307	785731	871639	7684066	663621	807943	768236	797085	809518	717139	789594	726816	7E+05

TABLE 8

BOTSWANA SULPHUR DIOXIDE DATA 1995

ug/m3 Determined by Hydrogen peroxide Absorption Method

MONTH	CRITERIA	GRB MONITORING STATION		
		Francistown Works Depot	Lobatse Bus Terminal	Palapye GRB Hospital
January	24hr. max	40	20	20
	mean	20	20	20
February	24hr. max	100	100	100
	mean	20	30	20
March	24hr. max	20	20	20
	mean	20	20	20
April	24hr. max	90	60	90
	mean	30	30	30
May	24hr. max	30	60	40
	mean	20	20	20
June	24hr. max	20	40	40
	mean	20	20	20
July	24hr. max	30	20	120
	mean	20	20	40
August	24hr. max	40	60	50
	mean	20	20	20
September	24hr. max	210	30	100
	mean	60	30	30
October	24hr. max	110	50	30
	mean	60	20	20
November	24hr. max	100	100	210
	mean	30	20	30
December	24hr. max	60	40	70
	mean	20	20	20
1995 Mean		30	20	20

TABLE 9

DEPARTMENT OF MINES- AIR POLLUTION MONITORING
ANNUAL TSP DATA FOR 1995

MONTH	CRITERIA	LOBATSE	PALAPYE	FRANCISTOWN
		BUS TERMINAL	GRB HOSPITAL	FTC WORKS DEPOT
JANUARY	Max	54	25	17
	Mean	44	15	13
FEBRUARY	Max	-	76	20
	Mean	-	43	14
MARCH	Max	43	25	25
	Mean	28	15	22
APRIL	Max	20	28	25
	Mean	16	15	20
MAY	Max	39	17	25
	Mean	30	9	21
JUNE	Max	93	18	34
	Mean	45	17	22
JULY	Max	28	43	37
	Mean	38	39	32
AUGUST	Max	72	30	50
	Mean	51	24	38
SEPTEMBER	Max	85	43	45
	Mean	49	25	38
OCTOBER	Max	54	-	-
	Mean	39	-	-
NOVEMBER	Max	94	-	-
	Mean	61	-	-
DECEMBER	Max	74	67	143
	Mean	53	8	14
ANNUAL	Max	90	80	140
	Mean	40	20	20

TABLE 10

MMADINARE MONITORING

MONTH	CRITERIA	MMADINARE				
		CO	SO2	TTT	SIG	WS
JULY	24 hr.max		0	19	44	2.8
	mean		0	18	19	1.84
AUGUST	24 hr.max	2.949	0.213	25	56	4.59
	mean	1.587	0.0156	21.81	21.31	2.3
SEPTEMBER	24 hr.max	1.506	0.101	29	64	5.75
	mean	1.392	0.018	22.31	28.75	247.88
OCTOBER	24 hr.max	1.281	0.106	32	60	6.9
	mean	0.013	0.033	25.81	29.31	2.75
NOVEMBER	24 hr.max	0.023	0.088	30	19	1.22
	mean	0.023	0.07	29.5	17	110.5
DECEMBER	24 hr.max	0.062	0.384	30	58	1.02
	mean	0.037	0.257	28.5	54.8	0.725
1995 Mean		0.0077	0.079	24.32	28.36	60.99

TABLE 11

MMADINARE WIND DATA

MONTH	WIND DIRECTION (percent frequency)															
	S to N	SSW to NNE	SW to NE	WSW to ENE	W to E	WNW to ESE	NW to SE	NNW to SSE	N to S	NNE to SSW	NE to SW	ENE to WSW	E to W	ESE to WNW	SE to NW	SSE to NNW
July	9.1	81.8	9.1	0	0	0	0	0	0	0	0	0	0	0	0	0
August	-	-	6.5	-	32.3	41.9	6.5	-	-	3.2	3.2	-	-	3.2	3.2	-
September	0	0	0	0	25	62.5	0	6.25	0	0	6.25	0	0	0	0	0
October	0	0	0	12.5	50	8.3	4.2	8.3	0	4.2	0	0	0	0	0	0
November	0	0	0	0	50	0	8.3	0	0	0	0	0	0	0	0	0
December	0	0	0	25	0	0	0	0	25	0	0	0	0	0	0	0
1995 Mean	2	16	3	8	26	19	0	3	5	1	2	0	0	1	1	0

TABLE 12

TONOTA MONITORING

MONTH	CRITERIA	TONOTA			
		SO2	TTT	SIG	WS
JULY	24 hr.max	0.007	24	43	3.15
	mean	0.0048	18.6	26.6	1.88
AUGUST	24 hr.max	0.049	25	6.41	3.36
	mean	0.0062	19.35	2.62	1.28
SEPTEMBER	24 hr.max	0.017	27	67	4.17
	mean	0.0039	22.56	26.37	2.65
OCTOBER	24 hr.max	0.061	34	72	7.57
	mean	0.0079	27.2	39.77	2.47
NOVEMBER	24 hr.max	0.072	32	73	6.21
	mean	0.0095	26.2	31.37	2.76
DECEMBER	24 hr.max	0.052	27	75	4.87
	mean	0.0137	24.03	38.17	2.04
1995 Mean		0.0077	22.99	27.48	2.18

TABLE 13

Summary of Effluent Analyses from the BCL Mine and the Motloutse/Letlhakane Rivers' System for 1995

SITE NO	SOURCE	Temp	pH	DS (mg/l)	Cu (mg/l)	Ni (mg/l)	Mn (mg/l)	Fe (mg/l)
1	No.3 Shaft	26	6.4	2	0.04	4.93	0.96	2.99
2	No.3B Pollution	24	7.8	214	0.05	1.88	0.49	1.59
3	Main Drain	28	6.8	619	0.66	7.52	0.72	2.47
4	V-Notch	21	5.7	852	0.08	5.14	1.94	3.40
5	Tailings Dam	24	7.9	2	0.15	3.38	0.74	16.75
6	Clear Water Dam	22	3.7	4	0.37	9.09	18.86	130.47
7	Seepage Dam	23	3.8	5	0.40	9.82	22.72	143.03
8	Mathathane river	22	6.0	851	0.10	4.72	2.39	1.29
9	Motloutse 3km upstream	24	7.1	449	0.04	1.74	0.61	2.25
10	Letlhakane river	23	10.5	372	0.05	1.94	0.59	0.59
11	Motloutse/Letlhakane river	25	8.0	353	0.04	2.09	0.59	2.23
12	Motloutse 5km downstream	23	7.4	333	0.05	2.01	0.90	0.40
13	Motloutse 20km downstream	26	7.4	132	0.04	2.02	0.45	1.14
14	Selebi-Mine	26	6.7	66	0.09	19.11	0.96	2.14
15	Railway track	22	3.5	172	1.34	11.35	3.29	5.12
16	No.1 Shaft	24	7.2	2	0.04	17.77	1.94	4.48
17	Mmadinare Dairy Farm	23	6.9	451	0.03	5.55	1.97	1.84
18	Mmadinare Dairy Farm	20	7.0	470	0.03	4.02	2.06	1.70
19	Mmadinare Dairy Farm	20	5.9	460	0.03	3.95	1.92	1.43

WHO GUIDELINE FOR SEASONAL STREAMS

Reservoir - the water is not for consumption. Drinking water standards do not apply.

Discharge points or channel - this directs the overflow from reservoirs to the natural streams.

This point is critical regarding the the monitoring of pollutants reaching the natural stream.

Appendix AA

Main goal, main functions and objectives for the Air Pollution Control Division at DoM

Main goal

To promote sustainable industrial and economic growth by ensuring that the overall environment is not exposed to unnecessary risks resulting from industrial and other human activities.

Main functions

1. To issue and administer Air Pollution Permits countrywide.
2. To inspect polluting plants and/or processes.
3. To sample and analyze for pollutants.
4. To render advisory services on air pollution matters.
5. To implement air pollution legislation and policy development.
6. To carry out identification and citing of Air Pollution monitoring stations.

Objectives

- I. To prevent the pollution of the atmosphere by industries and other anthropogenic activities.
- II. To continuously monitor the air quality in the country to determine if the public and the environment are exposed to high levels of air pollution.
- III. To promote the concept of pollution prevention in high levels of air pollution.

Appendix BB

Working plan for November 1996 to November 1997

Date finished	Resp. person	No.	Milestones	Milestone report	Verifiable indicators	
Nov 1997	TOB	I 1	NEW MONITORING PROGRAM AND FIELD EQUIPMENT When siting report/siting study is complete New monitoring prog. is designed and given priority New AQ monitoring prog. for Botswana is decided Siting study of new monitoring program is complete Procurement list for new monitoring equip. exist Instruments are procured Instruments are put up in field	Date 17/12/96: Finished. More work than expected.	Report List to DoM Report Siting report Procurement list Procurement list Report	
Jan 1997	TOB	I 2				
Feb 1997	DoM	I 3				
March 1997	TOB, SK	I 4				
March 1997	RD	I 5				
June 1997	DoM	I 6				
Dec 1997	DoM	I 7				
April 1997	SK	D 1	DATA STORING Procedures for preliminary storing of data is established		Procedures reported	
April 1997	SK	D 2	Procedures for the final data base is established		Procedures reported	
April 1997	SK	D 3	Standard statistical procedures for data are established		Note	
Oct. 1997	SK	E 1	USE OF AQ/METEOROLOGICAL MEASUREMENTS Training in use of statistical programs completed		Mission report	
April 1997	SK, TOB	M 1	APPLICATION OF AQ MODELLING Training in meteorology is performed		Mission report	
April 1997	TOB, SK	M 2		On-the-job training in CONCX is complete		Mission report
Oct. 1997	TOB, SK	M 3		On-the-job training in CONCX is complete		Mission report
Oct. 1997	SK, TOB	M 4		Training in meteorology (met.freq matrix, ...) is performed		Mission report
Oct. 1997	SK, TOB	M 5		Introduction to CONDEP is performed		Mission report
Oct. 1997	TOB, SK	M 6		On-the-job training in CONDEP is performed		Mission report
March 1997	DoM	C 1	CHEMICAL LABORATORY QA/QC system is established		Report	
March 1997	OH	C 2		QA/QC guidelines are designed		Report on guidelines
Sept. 1997	OH	C 3		Training program at NILU performed (1. person)		Mission report
Dec. 1997	DoM	C 4		Method for analysis of VOC in air developed		Report
Dec. 1997	DoM, OH	C 5		A complete QA/QC system for the laboratory is established		Reports/forms
Dec. 1997	DoM	C 6		Laboratory equipments are procured		Procurement list

Appendix CC

Budget for November 1996 to November 1997

Date finished	No.	Milestones	Prep. at NILU	Work in Botswana	Total no. of days	Total cost (hours)	Total cost for work in Botswana	Allowance Botswana	Travel
Nov 1997	I 1	NEW MONITORING PROGRAM AND FIELD EQUIPMENT When siting report/siting study is complete New monitoring prog. is designed and given priority New AQ monitoring prog. for Botswana is decided Siting study of new monitoring program is complete Procurement list for new monitoring equip. exist Instruments are procured Instruments are put up in field			-				
Jan 1997	I 2			5	7	36,960	26,400	4,200	
Feb 1997	I 3				5	26,400	79,200	12,600	8,000
March 1997	I 4			1	16	84,480			
March 1997	I 5				5	26,400			
June 1997	I 6			3	40	227,040	211,200	33,600	8,000
Dec 1997	I 7				43				
April 1997	D 1	DATA STORING Procedures for preliminary storing of data is established Procedures for the final data base is established Standard statistical procedures for data are established		11	11	58,080	58,080	9,240	8,000
April 1997	D 2			12	12	63,360	63,360	10,080	
April 1997	D 3			14	14	73,920	73,920	11,760	
Oct. 1997	E 1	USE OF AQ/METEOROLOGICAL MEASUREMENTS Training in use of statistical programs completed	3	12	15	79,200	63,360	10,080	8,000
April 1997	M 1	APPLICATION OF AQ MODELLING Training in meteorology is performed On-the-job training in CONCX is complete On-the-job training in CONCX is complete Training in meteorology (met.freq matrix, ...) is performed Introduction to CONDEP is performed On-the-job training in CONDEP is performed	1	5	6	31,680	26,400	4,200	8,000
April 1997	M 2		2	20	22	116,160	105,600	16,800	
Oct. 1997	M 3		2	20	22	116,160	105,600	16,800	8,000
Oct. 1997	M 4		2	5	7	36,960	26,400	4,200	
Oct. 1997	M 5		2	4	6	31,680	21,120	3,360	
Oct. 1997	M 6		2	20	22	116,160	105,600	16,800	
March 1997	C 1	CHEMICAL LABORATORY QA/QC system is established QA/QC guidelines are designed Training program at NILU performed (1. person) Method for analysis of VOC in air developed A complete QA/QC system for the laboratory is established Laboratory equipments are procured				0	0	0	8,000
March 1997	C 2		20	10	30	158,400	52,800	8,400	
Dec. 1997	C 3		25		25	132,000	0	0	
Dec. 1997	C 4				5	0	0	0	8,000
Dec. 1997	C 5		5	10	15	26,400	26,400	4,200	
Dec. 1997	C 6			15	50	79,200	52,800	8,400	
		Administration Annual/status reports		30	80	264,000	12,600		
				418	2,207,040	1,098,240	212,520	64,000	
							Total budget 1997:	2,483,560	

